



KING COUNTY

1200 King County Courthouse
516 Third Avenue
Seattle, WA 98104

Signature Report

July 21, 2008

Ordinance 16213

Proposed No. 2007-0443.2

Sponsors Constantine, Phillips and Ferguson

1 AN ORDINANCE regarding facilities for important county
2 functions; designating Sabey Data Center, Building Five as
3 the county's enterprise data center location, and authorizing
4 the King County executive to enter into a thirty-year lease
5 agreement for 11,474 square feet of space, located at the
6 Intergate East technology campus, 3355 South 120th Place,
7 in Seattle, Washington, to be used for a data center facility,
8 located in council district 8.

9
10 BE IT ORDAINED BY THE COUNCIL OF KING COUNTY:

11 SECTION 1. The King County executive is hereby authorized to execute a thirty
12 year lease with Sabey Corporation for approximately 11,474 square feet of space located
13 at Sabey Data Center – Building 5 at the Intergate East Technology campus, 3355 South
14 120th Place, Seattle, Washington consistent with the applicable terms and conditions
15 described in Attachment A to this ordinance, Proposal for King County Data Center at
16 Sabey Data Center – Building 5 and containing the usual and customary terms for such a
17 lease.

18 SECTION 2. The appropriate county officials, agents and employees are hereby
19 authorized to take all actions necessary to implement the lease and all actions up to now
20 taken by county officials, agent and employees consistent with the terms and purposed of
21 the lease agreement are hereby ratified, confirmed and approved.

22 SECTION 3. If any one or more of the covenants or agreements provided in this
23 ordinance to be performed on the part of the county is declared by any court of competent
24 jurisdiction to be contrary to law, then such covenant or covenants, agreement or
25 agreements are null and void and shall be deemed separable from the remaining
26 covenants and agreements of this ordinance and in no way affect the validity of the other
27 provisions of this ordinance or of the lease.

28 SECTION 4. The King County executive is hereby authorized to execute a thirty-
29 year lease under the terms and conditions described in Attachment A to this ordinance,
30 Proposal for King County Data Center at Sabey Data Center – Building 5 at the following
31 location: 3355 South 120th Place, Seattle, Washington. In accordance with K.C.C.
32 4.04.040, the King County council may adopt an ordinance permitting the county

33 to enter into contracts requiring the payment of funds from the appropriation of
34 subsequent fiscal years.

35

Ordinance 16213 was introduced on 8/27/2007 and passed by the Metropolitan King
County Council on 7/21/2008, by the following vote:

Yes: 9 - Ms. Patterson, Mr. Dunn, Mr. Constantine, Ms. Lambert, Mr. von
Reichbauer, Mr. Ferguson, Mr. Gossett, Mr. Phillips and Ms. Hague

No: 0

Excused: 0

KING COUNTY COUNCIL
KING COUNTY, WASHINGTON



Julia Patterson, Chair

ATTEST:

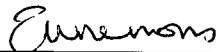

Anne Noris, Clerk of the Council

APPROVED this 1 day of August, 2008.

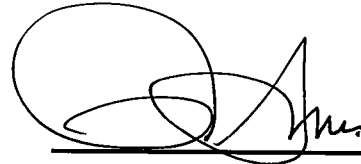

Ron Sims, County Executive

Attachments

A. Data Center Lease Agreement, date July 16, 2008, B. King County Data Center
Design Criteria--Dated February 16, 2007

RECEIVED
2008 AUG -1 PM 4: 27
KING COUNTY COUNCIL
CLERK

16213

July 16, 2008

Attachment A.

■ _____ ■

DATA CENTER LEASE AGREEMENT

BY AND BETWEEN

SABEY DATACENTER LLC,

a Washington limited liability company

Landlord

and

KING COUNTY,

a Political Subdivision of the State of Washington

Tenant

TABLE OF CONTENTS

Page

1.	FUNDAMENTAL LEASE PROVISIONS; DEFINITIONS; EXHIBITS.....	1
	1.1. Broker.....	1
	1.2. Building.....	1
	1.2.1. Common Areas.....	1
	1.3. Data System.....	1
	1.4. Premises.....	1
	1.4.1. Tenant's Rooftop Antenna.....	1
	1.5. Services.....	1
	1.6. Software.....	1
	1.7. Property.....	1
	1.8. Lease Year.....	1
	1.9. Commencement Date.....	1
	1.9.1. Early Occupancy.....	1
	1.10. Expiration Date.....	1
	1.10.1. Shared Infrastructure.....	1
	1.11. Term.....	1
	1.12. Base Rent.....	1
	1.12.1. Tenant Contribution for Tenant Improvements.....	1
	1.13. Additional Rent.....	1
	1.14. Security Deposit.....	1
	1.15. Parking.....	1
	1.16. Landlord's Payment Address.....	1
	1.17. Notice Addresses.....	1
	1.18. Permitted Uses.....	1
	1.19. Landlord's Work.....	1
	1.20. Tenant's Work.....	1
	1.21. Guarantor.....	1
	1.22. Exhibits.....	1
2.	PREMISES.....	1
	2.1. Acceptance of Premises.....	1
	2.2. Installation of Data System.....	1
	2.3. Tenant's Right of First Refusal.....	1
3.	LEASE TERM.....	1
	3.1. Duration of Lease Term.....	1
	3.2. Confirmation of Commencement Date.....	1
	3.3. Extension Term.....	1
	3.4. Base Rent During Renewal Term(s).....	1
	3.5. Surrender of Premises.....	1
	3.6. Holding Over With Consent.....	1
	3.7. Holding Over Without Consent.....	1
4.	RENT.....	1
	4.1. Payment.....	1
	4.1.1. Wire Payments.....	1
	4.2. Interest on Late Payments; Late Charge.....	1
	4.3. Address for Payments.....	1
5.	SECURITY DEPOSIT.....	1
6.	USES; COMPLIANCE WITH LAWS.....	1
	6.1. Permitted Uses.....	1
	6.2. Duties and Prohibited Conduct.....	1
	6.3. Environmental, Health And Safety Laws.....	1

7.	SERVICES AND UTILITIES; REPAIRS AND MAINTENANCE.....	11
7.1.	Services and Utilities; Landlord's Obligations.....	11
7.2.	Services and Utilities; Tenant's Obligations.....	12
7.3.	Interruption.....	12
7.4.	Landlord's Repair and Maintenance Obligations.....	12
7.5.	Tenant's Repair and Maintenance Obligations.....	12
7.6.	Additional Security.....	13
7.7.	Tenant's Obligations.....	13
7.8.	Landlord's Delay for Landlord's Work.....	13
8.	ADDITIONAL RENT.....	14
8.1.	Definitions.....	14
8.1.1.	Taxes.....	14
8.1.2.	Infrastructure Operating Costs.....	14
8.1.3.	Operating Costs.....	15
8.1.4.	Tenant's Share.....	17
8.1.5.	Tenant's Utility Charges.....	17
8.2.	Payment of Additional Rent for Estimated Operating Costs and Taxes.....	17
8.3.	Reconciliation.....	18
8.4.	Determinations.....	18
8.5.	Tenant's Personal Property Taxes.....	19
9.	IMPROVEMENTS AND ALTERATIONS BY TENANT.....	19
10.	ACCESS.....	19
11.	DAMAGE OR DESTRUCTION.....	20
11.1.	Damage and Repair.....	20
11.2.	Destruction During Last Year of Term.....	20
11.3.	Business Interruption.....	20
11.4.	Tenant Improvements.....	20
11.5.	Express Agreement.....	21
12.	WAIVER OF SUBROGATION.....	21
13.	INDEMNIFICATION.....	21
14.	INSURANCE.....	22
14.1.	Worker's Compensation.....	22
14.2.	Liability Insurance.....	23
14.3.	Property Insurance.....	23
14.4.	Automobile Liability Insurance Requirements.....	23
14.5.	Insurance Policy Requirements.....	23
14.6.	Self-Insurance.....	23
14.7.	Failure to Maintain Insurance.....	24
14.8.	Increased Insurance Costs.....	24
15.	ASSIGNMENT AND SUBLETTING.....	24
15.1.	Assignment or Sublease.....	24
15.2.	Documentation and Expenses.....	25
15.3.	Transferee Obligations.....	25
16.	SIGNS.....	25
17.	LIENS.....	26
18.	BANKRUPTCY.....	26
18.1.	Assumption of Lease.....	26
18.1.1.	Definition of Adequate Assurances.....	26
18.2.	Assignment of Lease.....	26

18.2.	Assignment of Lease.....	1
18.3.	Adequate Protection.....	1
19.	DEFAULT.....	1
19.1.	Cumulative Remedies.....	1
19.2.	Tenant's Default; Right to Cure.....	1
19.3.	Landlord's Rights And Remedies.....	1
19.3.1.	Termination of Lease.....	1
19.3.2.	Re-entry of the Premises.....	1
19.3.3.	Termination After Reentry.....	1
19.4.	Landlord's Damages.....	1
19.4.1.	Delinquent Rent.....	1
19.4.2.	Rent After Termination Until Judgment.....	1
19.4.3.	Rent After Judgment.....	1
19.4.4.	Leasing Concessions.....	1
19.4.5.	Other Compensation.....	1
19.4.6.	Additional or Alternative Damages.....	1
19.4.7.	Calculation of Damages.....	1
19.5.	Tenant's Property.....	1
19.6.	No Waiver.....	1
19.7.	Waiver of Notice.....	1
19.8.	Waiver of Redemption Rights.....	1
19.9.	Default by Landlord.....	1
20.	SUBORDINATION AND ATTORNTMENT.....	1
21.	REMOVAL OF PROPERTY.....	30
22.	CONDEMNATION.....	1
22.1.	Entire Taking.....	1
22.2.	Constructive Taking of Entire Premises.....	1
22.3.	Partial Taking.....	1
22.4.	Awards and Damages.....	1
23.	NOTICES.....	1
24.	COSTS AND ATTORNEYS' FEES.....	1
25.	LANDLORD'S LIABILITY.....	1
26.	LANDLORD'S CONSENT.....	1
27.	ESTOPPEL CERTIFICATES.....	1
28.	RIGHT TO PERFORM.....	1
29.	PARKING.....	1
30.	AUTHORITY.....	1
31.	GENERAL.....	1
31.1.	Headings.....	1
31.2.	Heirs and Assigns.....	1
31.4.	Entire Agreement.....	1
31.5.	Severability.....	1
31.6.	Force Majeure.....	1
31.7.	Right to Change Public Spaces.....	1
31.8.	Governing Law.....	1
31.9.	Building Directory.....	1
31.10.	Building Name.....	1
31.11.	Quiet Enjoyment.....	1
31.12.	Survival.....	1

	31.13. Lender's Consent.....	1
	31.14. Time.....	1
	31.15. Interpretation.....	1
	31.16. Execution.....	1
32.	PRIME LEASE; SUBLEASE PROVISIONS.....	1
	32.1. Prime Lease.....	1
	32.2. Landlord Representations.....	1
	32.3. Owner Agreements.....	1

DATA CENTER LEASE AGREEMENT

THIS DATA CENTER LEASE AGREEMENT ("Lease") is made this _____ day of _____, 2008 ("Effective Date"), between Sabey DataCenter LLC, a Washington limited liability company ("Landlord"), and King County, a political subdivision of the State of Washington, ("Tenant"). The parties agree as follows:

1. FUNDAMENTAL LEASE PROVISIONS; DEFINITIONS; EXHIBITS.

Capitalized terms used in this Lease shall have the meanings provided in this Section 1, unless otherwise specifically modified by provisions of this Lease.

1.1. Broker. "Broker" shall mean Washington Partners, Inc. A commission shall be paid by Landlord to Broker pursuant to a separate agreement between Landlord and Broker.

1.2. Building. "Building" shall mean the structure commonly known as Sabey DataCenter ("SDC"). The Building is situated on a portion of the real property legally described in Exhibit A and has a postal address of 3355 South 120th Place, Seattle, Washington 98168. Landlord may alter the boundary lines of the Land (defined below) on which the Building is located pursuant to a boundary line or lot line adjustment and without Tenant's consent so long as the Building remains within the Landlord's property.

1.2.1. Common Areas. "Common Areas" shall mean those areas within the Building that are available for common use by tenants and their invitees including parking facilities, sidewalks, public toilets, and service facilities. This also includes areas which may not be accessible to tenants, but which provide functional support to tenants. Common Areas do not include Shared Infrastructure.

1.3. Data System. "Data System" shall mean Tenant's computer hardware and other data and telecommunications equipment installed in the Premises for use by Tenant in the operation of its business from time to time during the Term, and subject to Landlord's prior written approval.

1.4. Premises. The "Premises" shall mean the space consisting of approximately 11,474 rentable square feet of space located in Suite 5201 of the Building (consisting of approximately 7,492 square feet of data center space ("Data Center Space") and 3,982 square feet of office/storage (consisting of 3,402 square feet of office and 580 square feet of storage space) ("Office Space") depicted on the floor plan attached to this Lease as Exhibit B. The Premises shall include the Tenant Improvements described in Exhibit C.

1.4.1. Tenant's Rooftop Antenna. In addition to the Premises described above in Paragraph 1.4, throughout the Term of this Lease, Tenant shall have the right to install conduits to connect to an antenna and/or a satellite dish, or Tenant may rent an existing or new antenna and/or satellite dish on the roof of the Building from Landlord at a cost commensurate with the average prevailing rate for other tenants in the Building. Landlord shall be responsible for all costs and expenses associated with the installation and maintenance of the rooftop equipment.

Alternatively, should Tenant elect to install a rooftop antenna rather than rent one from Landlord, tenant shall obtain Landlord's prior written approval before installation of the rooftop equipment, which shall not be unreasonably withheld, conditioned, or delayed. If installation of the antenna or satellite dish requires any roof penetrations, Tenant shall use a contractor approved by Landlord and shall cause such work to be done in a manner that will preserve any roof warranty held by Landlord. Tenant shall be responsible for all costs and expenses associated with the installation and maintenance of the rooftop equipment. Tenant shall have access to the rooftop equipment subject to Landlord's roof top rules and procedures. Landlord reserves the right at any time, upon fifteen (15) days' prior written notice to Tenant, to require that Tenant remove the rooftop equipment if it interferes with any other tenant's ability to conduct its business in the Building or if it impedes Landlord's ability to lease space in the Building. Tenant agrees to remove the rooftop equipment at the end of the Term of this Lease if so requested by Landlord, and to repair any damage to the Building's rooftop caused by such removal.

1.5. Services. "Services" shall mean those services provided to the Premises set forth in Exhibit C-2 attached hereto and made a part hereof.

1.6. Software. "Software" shall mean any software, data, information contained in documentation, and other information and intangibles used by Tenant to operate and maintain Tenant's business through the Data System.

1.7. Property. The Premises, Building, Land, and the improvements on the Land other than the Building, are sometimes collectively referred to in this Lease as the "Property".

1.8. Lease Year. "Lease Year" shall mean each twelve-month period commencing January 1 and ending December 31.

1.9. Commencement Date. Subject to Sections 2.1 and 3.1, "Commencement Date" shall mean the date when Tenant improvements are Substantially Complete, as defined in Section 5.2 of Exhibit C. Unless caused by Landlord's delay and subject to Section 7.9 of this Lease, if the Lease Term commences on a day other than the first day of a calendar month, then the Commencement Date as specified in the preceding sentence shall be deemed to be the first day of the next calendar month, and the Tenant shall be deemed to have been given Early Occupancy as of the date specified in the preceding sentence, with all terms of this Lease, including Rent, and other amounts due to Landlord, applicable to the period of early occupancy, EXCEPT that Tenant Contribution for Tenant Improvements shall be paid in the manner specified in Section 1.12.1.

1.9.1. Early Occupancy. Tenant will be allowed to occupy any square feet they feel is ready for occupancy before the Commencement Date ("Early Occupancy"). Early Occupancy shall mean any use of the Premises other than uses directly related to the installation of furniture and fixtures. Tenant shall have the right to access the Premises for such installation of furniture and fixtures as needed, but shall in all instances be coordinated with Landlord. Any increase in cost due to Tenant's interference with Landlord's activities shall be born by Tenant. Tenant's Early Occupancy shall not in any way diminish or excuse Landlord's obligations pursuant to Exhibit C ("Work Letter Agreement"). During Early Occupancy, "Base Rent" will be calculated by multiplying the actual occupied rentable square feet by One and 67/100 Dollars (\$1.67) per rentable square foot on a monthly basis for the Office Space and Three and 60/100 Dollars (\$3.60) per square foot on a monthly basis for the Data Center Space. Tenant will be responsible for all "Additional Rent" as described in Section 8 on the portion of the Premises that they occupy under this Early Occupancy clause.

1.10. Expiration Date. "Expiration Date" shall mean the date that is twelve (12) years after the Commencement Date, unless sooner terminated or extended in accordance with this Lease.

1.10.1. Shared Infrastructure. "Shared Infrastructure" shall mean that infrastructure that consists primarily of electrical and mechanical equipment and systems which service not only the Tenant, but also similar tenants within the Building. Shared Infrastructure does not include systems which support a single tenant, including all systems included as part of the Tenant Improvements. Landlord will maintain and operate this equipment in a professional and industry standard manner comparable to other data centers of equal quality to support building tenants. Shared electrical equipment includes but is not limited to back-up power generators, switchgear, transformers, monitoring and cabling which connects shared equipment. Shared mechanical or cooling equipment includes but is not limited to rooftop air handlers, chillers, pumps, piping, ductwork, and controls.

1.11. Term. "Term" shall mean a period of twelve (12) years, commencing on the Commencement Date and terminating on the Expiration Date, unless sooner terminated or extended in accordance with this Lease.

1.12. Base Rent. "Base Rent" means Data Center Base Rent and Office Space Base Rent and are sometimes referred to collectively as "Rent." "Data Center Base Rent" from the Commencement Date through the twelfth (12th) month shall mean Twenty-six Thousand Nine Hundred Seventy-one and 20/100 Dollars (\$26,971.20) per month.

"Data Center Base Rent" from the thirteenth (13th) month through the twenty-fourth (24th) month shall mean Twenty-seven Thousand Seven Hundred Eighty-two and 83/100 Dollars (\$27,782.83) per month.

"Data Center Base Rent" from the twenty-fifth (25th) month through the thirty-sixth (36th) month shall mean Twenty-eight Thousand Six Hundred Nineteen and 44/100 Dollars (\$28,619.44) per month.

"Data Center Base Rent" from the thirty-seventh (37th) month through the forty-eighth (48th) month shall mean Twenty-nine Thousand Four Hundred Eighty-one and 02/100 Dollars (\$29,481.02) per month.

"Data Center Base Rent" from the forty-ninth (49th) month through the sixtieth (60th) month shall mean Thirty Thousand Three Hundred Sixty-seven and 57/100 Dollars (\$30,367.57) per month.

"Data Center Base Rent" from the sixty-first (61st) month through the seventy-second (72nd) month shall mean Thirty-one Thousand Two Hundred Seventy-nine and 10/100 Dollars (\$31,279.10) per month.

"Data Center Base Rent" from the seventy-third (73rd) month through the eighty-fourth (84th) month shall mean Thirty-two Thousand Two Hundred Fifteen and 60/100 Dollars (\$32,215.60) per month.

"Data Center Base Rent" from the eighty-fifth (85th) month through the ninety-sixth (96th) month shall mean Thirty-three Thousand One Hundred Eighty-three and 32/100 Dollars (\$33,183.32) per month.

"Data Center Base Rent" from the ninety-seventh (97th) month through the one hundred eighth (108th) month shall mean Thirty-four Thousand One Hundred Seventy-six and 01/100 Dollars (\$34,176.01) per month.

"Data Center Base Rent" from the one hundred ninth (109th) month through the one hundred twentieth (120th) month shall mean Thirty-five Thousand One Hundred Ninety-nine and 91/100 Dollars (\$35,199.91) per month.

"Data Center Base Rent" from the one hundred twenty-first (121st) month through the one hundred thirty-second (132nd) month shall mean Thirty-six Thousand Two Hundred Fifty-five and 04/100 Dollars (\$36,255.04) per month.

"Data Center Base Rent" from the one hundred thirty-third (133th) month through the Expiration Date shall mean Thirty-seven Thousand Three Hundred Forty-one and 38/100 Dollars (\$37,341.38) per month.

Data Center Base Rent shall be payable as provided in Section 4.

Office Space Base Rent. "Office Space Base Rent" from the Commencement Date through the twelfth (12th) month shall mean Seven Thousand Seven Hundred Sixty-three and 33/100 Dollars (\$7,763.33) per month.

"Office Space Base Rent" from the thirteenth (13th) month through the twenty-fourth (24th) month shall mean Seven Thousand Nine Hundred Ninety-six and 23/100 Dollars (\$7,996.23) per month.

"Office Space Base Rent" from the twenty-fifth (25th) month through the thirty-sixth (36th) month shall mean Eight Thousand Two Hundred Thirty-six and 90/100 Dollars (\$8,236.90) per month.

"Office Space Base Rent" from the thirty-seventh (37th) month through the forty-eighth (48th) month shall mean Eight Thousand Four Hundred Eighty-five and 32/100 Dollars (\$8,485.32) per month.

"Office Space Base Rent" from the forty-ninth (49th) month through the sixtieth (60th) month shall mean Four Thousand Seven Hundred Forty-one and 51/100 Dollars (\$8,741.51) per month.

"Office Space Base Rent" from the sixty-first (61st) month through the seventy-second (72nd) month shall mean Nine Thousand-five and 47/100 Dollars (\$9,005.47) per month.

"Office Space Base Rent" from the seventy-third (73rd) month through the eighty-fourth (84th) month shall mean Nine Thousand Two Hundred Seventy-seven and 18/100 Dollars (\$9,277.18) per month.

"Office Space Base Rent" from the eighty-fifth (85th) month through the ninety-sixth (96th) month shall mean Nine Thousand Five Hundred Fifty-six and 66/100 Dollars (\$9,556.66) per month.

"Office Space Base Rent" from the ninety-seventh (97th) month through the one hundred eighth (108th) month shall mean Nine Thousand Eight Hundred Forty-three and 91/100 Dollars (\$9,843.91) per month.

"Office Space Base Rent" from the one hundred ninth (109th) month through the one hundred twentieth (120th) month shall mean Ten Thousand One Hundred Thirty-eight and 91/100 Dollars (\$10,138.91) per month.

"Office Space Base Rent" from the one hundred twenty-first (121st) month through the one hundred thirty-second (132nd) month shall mean Ten Thousand Four Hundred Forty-one and 68/100 Dollars (\$10,441.68) per month.

"Office Space Base Rent" from the one hundred thirty-third (133rd) month through the Expiration Date shall mean Ten Thousand Seven Hundred Fifty-six and 10/100 Dollars (\$10,756.10) per month.

Office Space Base Rent shall be payable as provided in Section 4.

1.12.1. Tenant Contribution for Tenant Improvements. The rates for Data Center Base Rent are based upon Landlord making Tenant Improvements in the amount of Nine Million Five Hundred Thousand Dollars (\$9,500,000.00) ("Not-To-Exceed Cost") to the Premises. The actual cost of the Tenant Improvements, up to the Not-To-Exceed Cost, shall be payable to Landlord by Tenant and due within thirty (30) days of Substantial Completion of Landlord's Work, as defined in Section 5.2 of Exhibit C. The Tenant Contribution for Tenant Improvements is not part of Additional Rent provided for in Section 1.13.

If Tenant occupies the Additional Space described in Section 2.3 of this Lease, Landlord shall make additional Tenant Improvements in an amount to be determined by negotiation with Tenant. Tenant shall make an additional Tenant contribution equal to the value of the Landlord's Tenant Improvement costs payable as Additional Rent within sixty (60) days after acceptance of the Additional Space.

1.13. Additional Rent. "Additional Rent" shall mean the amounts described in Section 8, excluding the Tenant Contribution for Tenant Improvements as defined in Section 1.12.1, as Building Operating Costs, Infrastructure Operating Costs, electrical utility costs and all other amounts except Base Rent which are payable by Tenant under this Lease.

1.14. Security Deposit. Intentionally deleted.

1.15. Parking. Subject to Section 29.

1.16. Landlord's Payment Address. "Landlord's Payment Address" shall mean: Sabey DataCenter LLC, P.O. Box 34108, Seattle, Washington 98124-1108. Tenant may also arrange for monthly wire transfer of Rent using the following information:

Bank: The Commerce Bank of Washington, 601 Union St., Suite 3600, Seattle, WA 98101; ABA # 125008013; Bank Account # 1173731; Account Name: Sabey Corporation, 12201 Tukwila International Blvd., Fourth Floor, Seattle, WA 98168-5121

1.17. Notice Addresses.

If to Landlord: Sabey DataCenter LLC c/o Sabey Corporation

12201 Tukwila International Blvd.
Fourth Floor
Seattle, WA 98168-5121
Attn: Sr. V.P. Real Estate
Fax No. 206-282-9951

with a copy to: Sabey Corporation
12201 Tukwila International Blvd.
Fourth Floor
Seattle, WA 98168-5121
Attn.: Sr. V.P. Property Operations & Leasing
Fax No. 206-282-9951

Landlord's Mortgagee (if any): [Need this from Sabey]

If to Tenant: King County
Facilities Management Division
Department of Executive Services
500 King County Administration Building
500 Fourth Avenue
Seattle, WA 98104-2337
Phone No. 206-616-3400, Fax No. 206-685-1547

1.18. Permitted Uses. "Permitted Uses" shall mean Tenant's use of the Premises for operating its Data System and ancillary office space, subject to the terms and conditions of this Lease.

1.19. Landlord's Work. "Landlord's Work" shall mean the improvements to be made by Landlord in accordance with Exhibit C.

1.20. Tenant's Work. "Tenant's Work" shall mean the improvements, if any, to be made by Tenant in compliance with Landlord's "Tenant & Tenant Contractor Construction Criteria," as may be updated and modified from time to time by Landlord.

1.21. Guarantor. Intentionally deleted.

1.22. Exhibits. The following exhibits or riders are attached to this Lease and are incorporated into this Lease by this reference:

- (a) Exhibit A - Legal Description
- (b) Exhibit B - Floor Plan of Premises
- (c) Exhibit C - Landlord's Work
- (d) Exhibit C-1 - Tenant's Removable Property
- (e) Exhibit C-2 - Services Offering
- (f) Exhibit C-3 - Approved Plans
- (g) Exhibit D - Rules and Regulations
- (h) Exhibit E - Parking Area

2. PREMISES. Landlord hereby leases to Tenant, and Tenant hereby leases from Landlord, the Premises described in Section 1.4 together with the Landlord's Work described on Exhibit C ("Tenant Improvements") and together with rights of ingress and egress over public and common areas in the Building and on the land legally described on Exhibit A, including all easements appurtenant to the land ("Land"). Tenant's lease of the Premises shall be subject to all of the terms and conditions of this Lease.

Landlord shall complete Landlord's Work in accordance with Exhibit C. Notwithstanding anything to the contrary in this Lease, Tenant shall provide Landlord and Landlord's contractor with such access to the Premises as may be required by Landlord and Landlord's contractor to efficiently perform Landlord's Work. Tenant acknowledges and agrees that Landlord shall have no obligation to improve the Premises except as may be expressly set forth on Exhibit C.

2.1. Acceptance of Premises. Landlord and Tenant hereby agree that Landlord's Work as set forth in Exhibit C shall be constructed by Landlord's contractor, Sabey Construction Inc., at Landlord's sole risk and liability. Tenant's acceptance of the Premises shall be deferred until the Substantial Completion of Landlord's Work as provided in Section 5.2 of Exhibit C. The existence and repair of punch list items shall not postpone the Commencement Date or the obligation of Tenant to pay Base Rent, Additional Rent, or the Tenant Contribution in Section 1.12.1. If after 30 days, Landlord has failed to diligently undertake repairs of punch list items previously identified by Tenant pursuant to the process for determining Substantial Completion contained in Section 5.2 of Exhibit C, the failure to repair such punch list items shall be considered a default by Landlord and subject to the provisions of Section 19.9.

2.2. Installation of Data System.

2.2.1 No later than thirty (30) days prior to the initial installation of Tenant's equipment by Tenant, Tenant shall submit to Landlord the following: (i) a detailed equipment list of all of the equipment that Tenant intends to install in the Premises, including, without limitation, as part of its Data System (including any additional equipment installed or placed in the Premises by or on behalf of Tenant, "Tenant's Equipment"), which list shall include the manufacturer, model number, serial number and electrical usage rating (if relevant) for each item of Tenant's Equipment, and (ii) detailed plans and specifications for Tenant's proposed installation of Tenant's Equipment in the Premises, including the weight of each item of Tenant's Equipment. Notwithstanding anything to the contrary contained in this Lease, all of Tenant's Equipment, and Tenant's plans for the installation thereof shall be subject to Landlord's written approval prior to installation. Landlord's approval shall not be unreasonably withheld, conditioned, or delayed. If Landlord has not responded to Tenant within ten (10) days of receipt of Tenant's plans, the plans shall be deemed approved at no cost to Tenant. Tenant shall pay to Landlord within ten (10) days after delivery of an invoice thereof, Landlord's actual costs and 1% markup thereon for Landlord's review of Tenant's plans and oversight of the installation of Tenant's Equipment, provided that Landlord has provided Tenant an estimate of said costs beforehand. Tenant may revise the scope of its equipment installation in order to reduce the costs associated with Landlord's review within ten (10) days of receipt from Landlord. If Landlord and Tenant fail to mutually agree on either the cost of review or the scope changes proposed by Tenant, Tenant shall advise Landlord in writing of its objection and pay Landlord its requested cost subject to subsequent binding arbitration regarding the appropriateness of such costs by a single arbitrator subject to the rules and qualifications contained in Section 8.4. Such binding arbitration must be arranged by Tenant within ten (10) days of objection. If the arbitrator decides that Tenant has been overcharged for Landlord's review, Landlord shall refund the overcharge, plus attorneys' fees as provided in Section 24, to Tenant within thirty (30) days of such decision. Following the initial installation of Tenant's Equipment, Landlord's approval shall only be required for replacement of existing servers with servers with different specifications than those already existing and only when the new replacement servers occupy one full rack or more of datacenter space. Tenant shall have no duty to notify Landlord or seek Landlord's approval to replace existing servers and equipment with servers and equipment with the same specifications as those being replaced, regardless of number.

2.2.2 Subject to Section 2.2.1 above, Tenant shall install within the Premises the approved Data System together with the related Software. All costs and expenses for such installation shall be the sole responsibility of Tenant. To the extent any such installations would constitute alterations hereunder, Tenant shall perform the same in accordance with Section 9 hereof. Tenant shall not place a load upon any floor of the Premises that exceeds either the load per square foot, which such floor was designed to carry, or that which is allowed by law. Landlord reserves the right to prescribe the weight and position of all heavy equipment.

2.3 Tenant's Right of First Refusal. During the Term of the Lease, Tenant shall have a right of first refusal ("Right of First Refusal") to lease approximately 3,114 rentable

square feet of data center space adjacent to the Premises (such space being referred to herein as an "Additional Space"), on the same terms and conditions that Landlord is prepared to accept from any third party; provided that any tenant improvement package shall be of equal dollar value rather than the same improvements, except that if Landlord's notice to Tenant is within the first 24 months of the Lease Term, the Rent will be the same rate as for the initial Premises and Landlord will construct all necessary Tenant Improvements in the same manner and subject to the same terms, program design criteria, and conditions as the Tenant Improvements for the Premises. When Landlord receives an offer to lease the Additional Space from a third party which Landlord desires to accept, Landlord shall present the same, in writing, to Tenant, and Tenant shall thereafter have ten (10) calendar days in which to accept or reject that offer by written notice to Landlord. Tenant's acceptance shall be conditioned upon approval by the King County Council's adoption of an ordinance authorizing such acceptance within forty-five (45) days of acceptance, or absent that approval by ordinance, Tenant shall be entitled to terminate the lease for Additional Space within forty-five (45) days of acceptance with no further obligations or liability to either Landlord or Tenant. If Tenant rejects that offer or fails to accept the same in writing within that time, then Landlord shall be free to lease the Additional Space to the third party on substantially similar terms and conditions to those offered to Tenant in the foregoing manner.

Each Right of First Refusal shall, at Landlord's election, be null and void if Tenant is in default under the Lease at the date Landlord would otherwise notify Tenant of the offer concerning the Additional Space or at any time thereafter and before commencement of the Lease for the Additional Space. After Tenant validly exercises a Right of First Refusal provided in this Lease, the parties shall execute an amendment to the Lease adding the Additional Space, or a new lease for the Additional Space, or such other documentation as Landlord shall require, promptly after Landlord shall prepare the same, confirm the leasing of such Additional Space to Tenant, but an otherwise valid exercise of the Right of First Refusal contained in this Lease shall be fully effective, whether or not such confirmatory documentation is executed.

If Tenant exercises a Right of First Refusal granted in this Lease, Landlord does not guarantee that the Additional Space will be available on the commencement date for the Lease thereof if the then-existing occupants of the Additional Space shall hold over, or for any other reason beyond Landlord's reasonable control. In that event, Tenant's sole recourse shall be that the rent with respect to the Additional Space shall be abated until Landlord legally delivers the same to Tenant. Tenant's exercise of that Right of First Refusal shall not operate to cure any default by Tenant of any of the terms or provisions in the Lease, nor to extinguish or impair any rights or remedies of Landlord arising by virtue of such default. Each and all Rights of First Refusal are personal to Tenant and may not be exercised or enjoyed by any other person or entity. If the Lease or Tenant's right to possession of the Premises shall terminate in any manner whatsoever before Tenant shall exercise a Right of First Refusal, or if Tenant shall have subleased or assigned its right to possess all or any portion of the Premises, then immediately upon such termination, sublease, or assignment, the Right of First Refusal shall simultaneously terminate and become null and void. Under no circumstances whatsoever shall a subtenant under a sublease of the Premises, or the assignee under a full or a partial assignment of the Lease, have any right to exercise a Right of First Refusal granted in this Lease.

3. LEASE TERM.

3.1. **Duration of Lease Term.** Tenant's lease of the Premises shall commence on the Commencement Date and terminate on the Expiration Date or such earlier or later date as may be provided for under this Lease. Notwithstanding anything to the contrary in Section 1.9, if Landlord is unable to deliver possession of the Premises to Tenant with Landlord's Work constructed by Landlord's contractor substantially completed in accordance with Exhibit C on the date specified in Section 1.9 and such delay (to the extent of such delay) is due to no fault on the part of Tenant, then the Commencement Date shall be the earlier of the date on which Tenant first occupies the Premises or the date that is five (5) days from the date of Landlord's written notice to Tenant of Substantial Completion of Landlord's Work constructed by Landlord's contractor provided for in Section 2, above. In no event shall Landlord be liable for damages, other than in Section 7.9, caused by any such delay or failure to deliver possession of the Premises.

3.2. Confirmation of Commencement Date. If the Commencement Date is not the date indicated in Section 1.9, Landlord will confirm the Commencement Date to Tenant in writing within a reasonable time after delivery of the Premises in accordance with this Lease.

3.3. Extension Term. The Term of this Lease shall automatically renew for (two) additional periods of five (5) years and two (2) subsequent four (4) year periods (the "Renewal Term(s)") on the same terms and conditions of this Lease as are provided for in the initial Term, except as provided below in this Section 3.3 or in Section 3.4 and without any free Rent periods or Tenant Improvement allowances. Unless Tenant gives written notice to Landlord at least twelve (12) months before the date of expiration of the initial Term or subsequent Renewal Term, as the case may be, that it will be vacating the Premises, this Lease will automatically renew upon the date of expiration of the initial Term of this Lease or the prior Renewal Term, as the case may be. Once such notice is delivered to Landlord, it shall be irrevocable by Tenant. Tenant acknowledges and agrees that notwithstanding anything to the contrary in this Lease, the automatic Renewal Term shall not extend to any assignee or subtenant of Tenant, or to any space assigned or subleased by Tenant, and any attempt to do so by any such assignee or subtenant, or by Tenant in connection with such assigned or subleased space, shall be deemed null and void.

3.4. Base Rent During Renewal Term(s). In the event that Tenant elects to extend the Term of this Lease in accordance with the terms of Section 3.3, the Base Rent for each year during each Renewal Term shall increase by three percent (3%) per year. The adjusted Base Rent shall commence on and be payable on the first day of each Renewal Term and shall continue thereafter throughout the Renewal Term.

3.5. Surrender of Premises. Subject to Section 11, Tenant shall promptly and peacefully surrender the Premises to Landlord upon the termination of the Lease Term in as good a condition as when received by Tenant from Landlord and/or as thereafter improved, if applicable, normal wear and tear excepted. Unless Landlord expressly provides otherwise in writing to Tenant, upon the expiration or termination of this Lease, all improvements and additions to the Premises except those items set forth on Exhibit C-1 shall be deemed property of Landlord and shall not be removed by Tenant from the Premises. Tenant shall be solely responsible for, and shall repair, all damage to the Property arising out of its surrender of the Premises. In addition to all other requirements under this Lease, Tenant shall remove any Hazardous Substances, as such term is defined in Section 6.3, on the Premises which were placed on the Premises by Tenant, its employees, agents, contractors and/or invitees, prior to its surrender and vacation of the Premises.

3.6. Holding Over With Consent. If Tenant remains in possession of the Premises after termination or expiration of the Lease Term with Landlord's written permission, such tenancy shall be deemed a month-to-month tenancy, which may be terminated by either party upon thirty (30) days' notice. During such tenancy, Tenant shall be bound by all of the terms, covenants and conditions in this Lease so far as applicable, except that the Base Rent shall be increased to the greater of (i) the then-quoted rates for similar space in the Building or (ii) one hundred fifty percent (150%) multiplied by the sum of the monthly installment of Base Rent payable for the last month of the Lease Term.

3.7. Holding Over Without Consent. If Tenant remains in possession of the Premises after the termination or expiration of the Lease Term without Landlord's prior written consent, Tenant shall become a tenant at sufferance only, subject to all the provisions of this Lease so far as applicable, except that Base Rent shall be increased to an amount equal to two hundred percent (200%) multiplied by the sum of the monthly installments of Base Rent payable by Tenant during the last month of the Lease Term, prorated on a daily basis. Acceptance by Landlord of Rent after the termination of the Lease Term shall not result in a renewal or extension of this Lease. The provisions of Section 3.6 and this Section 3.7 are in addition to, and shall not act as a waiver of or otherwise affect, Landlord's right of re-entry or any other rights of Landlord under this Lease or as provided by law or in equity. If Tenant fails to surrender the Premises upon the termination of the Lease Term, despite Landlord's demand to do so, Tenant shall indemnify, defend and hold Landlord harmless from and against all loss and liability, including, without limitation, any claim made by any succeeding tenant founded on, or resulting from, such failure to surrender, including without limitation, any attorneys' fees or costs associated therewith.

4. RENT.

4.1. Payment. Tenant shall pay Landlord the monthly installments of Data Center and Office Space Base Rent ("Base Rent") provided in Section 1.12 and Additional Rent provided in Section 1.13 in lawful money of the United States, in advance, on the Commencement Date and thereafter on or before the first day of each month throughout the Lease Term. Base Rent and Additional Rent shall be paid by Tenant without notice or demand, deduction, abatement, or offset, except as expressly provided herein. Base Rent and Additional Rent for any partial month at the beginning or end of the Lease Term shall be prorated in proportion to the number of days in such month. Base Rent and Additional Rent are collectively referred to in this Lease as "Rent."

4.1. Wire Payments. Any amounts payable to Landlord under this Lease in excess of Ten Thousand and No/100 Dollars (\$10,000.00) per occurrence shall be made by wire transfer as follows:

Bank: The Commerce Bank of Washington, 601 Union St., Suite 3600, Seattle, WA 98101; ABA # 125008013; Bank Account # 1173731; Account Name: Sabey Corporation, 12201 Tukwila International Blvd., Fourth Floor, Seattle, WA 98168-5121. Should Tenant fail to wire amounts above Ten Thousand Dollars (\$10,000), a one-half of one percent (0.5%) fee will be charged for handling the check.

4.2. Interest on Late Payments; Late Charge. If any Base Rent or Additional Rent is not paid on the due date thereof: (i) such overdue amounts shall bear interest at a rate equal to the prime rate plus eight percent (8%) per annum; and (ii) Tenant shall pay Landlord a late charge equal to three percent (3%) of such overdue amount. The parties hereby agree that such late charge represents a fair and reasonable estimate of the costs Landlord will incur by reason of late payment by Tenant, the exact amount of which would be difficult to ascertain. Acceptance by Landlord of any partial amounts due under this Section 4 shall in no event constitute a waiver of Tenant's default with respect to any overdue amount, nor prevent Landlord from exercising any of its other rights and remedies granted under this Lease or by law or in equity.

4.3. Address for Payments. Tenant shall pay all Rent to Landlord at Landlord's Payment Address, or at such other place as may be designated by Landlord from time to time by written notice to Tenant.

5. SECURITY DEPOSIT. Intentionally deleted.

6. USES; COMPLIANCE WITH LAWS.

6.1. Permitted Uses. Tenant expressly acknowledges that the Premises are to be used only for the Permitted Uses, and for no other business or purpose without the prior written consent of Landlord, which consent may be withheld by Landlord, in its sole discretion. Tenant acknowledges that Landlord may lease, or otherwise permit the use of, other space in the Building to others for uses including the location and usage of electronic equipment and data centers. Tenant shall not vacate or abandon the Premises, or a significant portion thereof, Tenant agrees to conduct normal business operations of the Permitted Uses within the Premises on a continuous basis, except for weekends, holidays and temporary closures not to exceed two (2) continuous weeks.

6.2. Duties and Prohibited Conduct. Notwithstanding anything to the contrary in this Lease, Tenant shall not commit any act that will increase the then-existing rate of insurance on the Building without Landlord's prior written consent. Tenant shall promptly pay upon demand the amount of any increase in insurance rates caused by the Permitted Uses or by any act or acts of Tenant or its employees, agents or representatives. Tenant shall not commit or allow to be committed any waste upon the Premises, or any public or private nuisance or other act which disturbs the quiet enjoyment of any other tenant of the Property or which is unlawful. Tenant shall not, without the written consent of Landlord, use any apparatus, machinery or device in or about the Premises, or act in any way, which will cause any substantial noise, or any vibration, fumes, or releases of Hazardous Substances into the surrounding environment. Tenant shall not use any equipment in the Premises in a manner so as to interfere with the use of the Building by other occupants or in a manner, which, in the opinion of Landlord, is not in accordance with generally accepted standards of internet access and use. If any of Tenant's office machines, equipment or activities, including the Data System or Tenant's Equipment or Tenant's use thereof, should disturb

the quiet enjoyment of any other occupant in the Building, cause any substantial noise, or cause any vibration, fumes or releases of Hazardous Substances, or interfere with any other equipment of any other Building occupant or Landlord's Building Systems then Tenant, at Tenant's sole expense, shall immediately stop such interference, provide adequate insulation or take such other action as may be necessary to eliminate such disturbance, noise, vibration, fumes, releases or interference. If Tenant fails to immediately remedy such vibration, fumes, releases or interferences Landlord shall have the right, but not the obligation, to immediately remedy the same at Tenant's expense. Tenant, at Tenant's expense, shall comply with all laws, rules, regulations, orders, ordinances and permits relating to the Premises, or its use or occupancy of the Premises, and shall observe such Rules and Regulations as set forth on Exhibit D to this Lease, and as may be modified by Landlord and made available to Tenant from time to time. This Lease shall be subject to all applicable zoning ordinances and to all municipal, county, state and federal laws and regulations governing or regulating the use of the Premises. If Tenant's Equipment or Tenant at any time causes any damage to, or increases the cost of maintenance of, the Premises, Building, or Landlord's operations, Landlord may demand that Tenant repair such damage or Landlord may elect to repair such damage itself at Tenant's sole cost and expense, and, without limiting any of Landlord's other rights and remedies in law or in equity, Landlord shall be entitled to reimbursement by Tenant for such costs of repair and any additional maintenance costs reasonably incurred within ten (10) days after notice to Tenant.

6.3. **Environmental, Health and Safety Laws.** Without limiting Tenant's obligations under this Section 6, Tenant in the exercise of its rights and the performance of its obligations under this Lease shall comply, at Tenant's expense, with all local, state, or federal laws, rules, regulations, ordinances, orders and permits now existing, or as hereafter enacted, amended, or issued concerning environmental, health, or safety matters (collectively, the "Environmental Laws"). Tenant shall not use the Premises for, or permit anything to be done in or about the Property which may subject Landlord, any guarantor, or any mortgagee under any mortgage covering the Property, to liability for remediation costs or other damages or penalties under any Environmental Laws resulting from Tenant's use of, or conduct on, the Property, including without limitation, the use, generation, transportation, management, handling, treatment, storage, manufacture, emission, release, disposal or deposit of any radioactive material, hazardous or toxic wastes, hazardous or toxic substances, any material containing hazardous wastes or hazardous substances (except as they occur in normal office products or household cleaning products), or any other pollutant, contaminant, human pathogen or infectious agent as such terms may now or in the future be defined in any Environmental Laws (collectively, "Hazardous Substances"), on the Property, adjacent surface waters, soils, underground waters, or air.

Landlord shall have the right at all reasonable times upon notice to Tenant to conduct environmental investigations, including the taking of samples, for the purpose of detecting or measuring the presence of Hazardous Substances on the Property. Tenant shall keep Landlord continuously informed by written notice of all Hazardous Substances, which Tenant, or Tenant's employees, agents, representatives, invitees, licensees, or contractors, generates, stores or otherwise allows on the Property. Tenant shall provide Landlord with copies of all documents received or prepared by Tenant concerning any release of a Hazardous Substance at the Property, all documents Tenant receives or prepares in connection with any violation, or alleged violation, of an Environmental Law by Tenant, and all reports or other documents Tenant is required to provide any governmental authority under any Environmental Law concerning any Hazardous Substance. Upon request by Landlord, Tenant shall provide Landlord with all other information, which Landlord reasonably deems necessary or useful for the purpose of determining whether Tenant is in compliance with all Environmental Laws and whether the Property, or any part of the Property, is contaminated by any Hazardous Substances. If Tenant or the Premises is in violation of any Environmental Law, or in the event of a release of Hazardous Substances into or on the Property or adjacent surface waters, soils, underground waters, or air, Tenant shall (i) immediately notify Landlord in writing of such occurrence and the action necessary to correct or mitigate such occurrence, and (ii) take such action as is necessary to mitigate and correct such violation or release. Provided, however, Landlord reserves the right, but not the obligation, to enter the Premises, to act in place of the Tenant (and Tenant hereby appoints Landlord as its agent for such purposes) and to take such action as Landlord deems necessary to ensure compliance or to mitigate the violation, at Tenant's expense. If Landlord has a reasonable belief that Tenant is in violation of any Environmental Law, or that Tenant's actions or inaction presents a threat of violation or a threat of

damage to the Property, Landlord reserves the right to enter the Premises and take such corrective or mitigating action as Landlord deems necessary. All costs and expenses incurred by Landlord in connection with any such actions shall become immediately due and payable by Tenant upon presentation of an invoice therefore.

Tenant shall not conduct or permit others to conduct environmental testing on the Premises without first obtaining Landlord's written consent. Tenant shall promptly inform Landlord of the existence of any environmental study, evaluation, investigation or results of any environmental testing conducted on the Premises whenever the same becomes known to Tenant, and Tenant shall provide copies to Landlord, upon request by Landlord and at no cost to Landlord. Notwithstanding the foregoing, in no event shall Tenant be responsible for or liable to Landlord for any Hazardous Substances located in the Premises that existed or were released upon the Premises prior to the Commencement Date of this Lease.

Notwithstanding any other provisions of this Lease, Tenant's obligations and responsibilities for the proper use, storage and maintenance of Hazardous Substances and for any breach of the obligations pursuant to this Paragraph 6.3, shall survive any expiration or any termination of this Lease.

7. SERVICES AND UTILITIES; REPAIRS AND MAINTENANCE.

7.1. Services and Utilities; Landlord's Obligations. Landlord shall supply Landlord's standard Building and Property security services and elevator service, Landlord's standard trash removal services (excluding disposal of Hazardous Substances or medical or biological waste) from the Building compactor, if any, electrical power access, and standard plumbing and water (including sewer) services. If the power provided by Landlord causes interference with the proper operation of Tenant's Equipment, Tenant will be responsible for providing at Tenant's sole expense any filtering or regulation devices within the Premises to correct the interference.

Except for the Office Space, the Base rental rate excludes the cost of electricity to the Premises including the estimated cost of electricity to supply the Premises with support from shared equipment such as chillers. These services shall be paid by Tenant each month as provided in Section 8. The cost for any services or utilities, which are not separately metered or sub-metered shall be based on Landlord's reasonable estimate of Tenant's consumption of such utilities. Landlord shall be entitled to install, maintain and operate, at Tenant's cost, a monitoring/ metering system(s) in the Premises to measure Tenant's consumption of electricity and HVAC, or to measure the added demands on the Premises electrical or HVAC systems resulting from Tenant's Equipment, including without limitation, Tenant Improvements pursuant to Exhibit C. Tenant shall utilize best practices (such as blanking plates) to insure that their space operates at a high level of efficiency. In no event shall Tenant's electrical power usage at any time exceed 1.2 megawatts of power, including Tenant's share of shared equipment such as chillers. Notwithstanding anything to the contrary contained herein, Tenant acknowledges that Landlord may, at its option, from time to time, conduct audits of its power systems to ensure that Tenant's usage thereof is in compliance with the terms of this Lease, including the amperage allocated to Tenant. If Landlord determines that Tenant is out of compliance, Landlord, at its option, and in addition to all other rights and remedies available to Landlord, may immediately require Tenant to disconnect any non-compliant piece of Tenant's Equipment, and charge Tenant for the costs of such additional electrical power consumed by such non-compliant piece of Tenant's Equipment.

Landlord's obligation to provide the services and utilities described in this Section 7.1 is subject to Section 11 (Damage and Destruction) and Section 22 (Condemnation).

Before installing fixtures, lights or Equipment in the Premises, which consume or require services or utilities exceeding the levels described in Exhibit C-2 hereto, Tenant shall obtain the written permission of Landlord. Landlord may refuse to grant such permission unless Tenant agrees to pay Landlord's costs, including Landlord's reasonable administrative fee, for installation of supplementary air conditioning capacity or electrical systems as necessitated by such equipment or lights. In addition, Tenant shall pay Landlord as Additional Rent the amount estimated by Landlord (including Landlord's administrative fee) as the cost of furnishing services or utilities for the operation of such equipment or lights and the cost of operation and maintenance of any supplementary air conditioning units necessitated by Tenant's use of such equipment or lights.

Tenant acknowledges that Landlord will restrict access to the Building in accordance with the Building's security system and security procedures, provided that Tenant shall have at all times during the Term of this Lease (24 hours of all days) reasonable access to the Premises, in accordance with such procedures.

If after request by Tenant, Landlord furnishes HVAC or other services or utilities in addition to the utilities or services required to be provided by Landlord under this Lease, including without limitation, furnishing utilities or services in amounts exceeding the levels described in Exhibit C-2 hereto, then the cost of such non-standard or additional services or utilities, as reasonably established by Landlord, shall be paid by Tenant as Additional Rent.

7.2. Services and Utilities; Tenant's Obligations. Tenant shall be solely responsible for providing, and shall pay as Additional Rent, all charges for any special janitorial services within the Premises and for any security services desired by Tenant in addition to Landlord's standard Building and site security services. It is understood that except as provided in Sections 7.1, 7.4, or with regard to the equipment, services and utilities listed in Exhibit C-2, and Landlord's obligations for construction, operation and maintenance, as well as any applicable warranties, for Tenant Improvements pursuant to Exhibit C, Landlord shall not be required to provide any services or utilities to Tenant, and Tenant shall make all necessary arrangements to have such services billed directly to Tenant and paid directly by Tenant.

7.3. Interruption. Notwithstanding anything to the contrary herein, Landlord shall not be liable for any loss, injury or damage to persons or property caused by or resulting from any temporary variation, interruption, or failure of equipment, services or utilities to be provided by Landlord under this Lease, with the exception of equipment, services or utilities set forth in Exhibit C-2 hereto, due to any cause whatsoever, including without limitation, Landlord's failure to make any repairs or perform any maintenance required to be performed by Landlord under this Lease. No temporary variation, interruption or failure of services or utilities to be provided by Landlord under this Lease incident to the making of repairs, alterations or improvements, or due to accident, strike or conditions or events beyond Landlord's reasonable control, shall be deemed an eviction of Tenant or relieve Tenant from any of Tenant's obligations under this Lease, provided that Landlord make best efforts to restore normal service as soon as possible, and further provided that where the failure to restore service has resulted in a material deviation from the performance levels specified in the Approved Plans, attached to Exhibit C (Work Letter Agreement), for a total of seven (7) days, Tenant shall have the right to resort to the actions specified in Section 19.9 (Default by Landlord).

7.4. Landlord's Repair and Maintenance Obligations. Except as provided in Sections 9 (Improvements and Alterations by Tenant), 11 (Damage or Destruction) or 22 (Condemnation), Landlord shall cause to be maintained in reasonably good order and condition the Building (other than any leased premises) and the public and common areas of the Property, such as lobbies, elevators, stairs, corridors, restrooms, and the Premises' water, if applicable; provided, however, Tenant shall be responsible for the cost of repair of damage occasioned by any act or omission of Tenant or Tenant's officers, contractors, agents, invitees, licensees or employees, subject to Section 12 (Waiver of Subrogation). Landlord shall maintain, repair and operate in compliance with the operation and performance standards provided in the Approved Plans, attached to Exhibit C, the equipment and systems listed in Exhibit C-2, including chilled water system (and associated controls), standby generator systems and associated electrical systems, UPS systems, power distribution units ("PDU"), and additionally the Tenant Improvements constructed by Landlord pursuant to the Work Letter Agreement attached hereto as Exhibit C. In conjunction with its maintenance and repair obligations pursuant to this Section 7.4, Landlord shall be responsible for the cost of repair from damage occasioned by any negligent act or omission of Landlord or Landlord's contractors, agents, invitees, licensees or employees, subject to Section 12 (Waiver of Subrogation).

7.5. Tenant's Repair and Maintenance Obligations. Except for maintenance, replacements and repairs required to be made or provided by Landlord under Sections 7.1 or 7.4, Tenant, at its sole cost and expense, shall provide for the maintenance in accordance with the manufacturer's recommendations, repair and replacement within the Premises and all built-in appliances and equipment and any private restrooms and associated plumbing, which are in the Premises for Tenant's exclusive use, light bulb replacement, and any security systems or services

desired by Tenant in addition to any such systems or services as may be provided by Landlord under this Lease. Tenant shall operate, maintain, and repair its equipment in such a manner as not to negatively impact the Shared Infrastructure. Tenant shall also, at its sole expense, maintain and repair its equipment, including, without limitation, to avoid hazard or damage to the Premises or injury to Landlord's employees, agents and suppliers or to the public. All of Tenant's Equipment shall be designed and constructed so as to prevent electromagnetic and radio frequency signal leakage. Upon notice from Landlord that any of Tenant's Equipment is causing or is likely to cause a hazard, interference, or service obstruction, Tenant shall forthwith eliminate such hazard, interference or service obstruction. Landlord reserves the right to disconnect such equipment until such hazard, interference, or service obstruction is corrected.

7.6 Additional Security. In the event that Tenant's use of the Premises, or its presence in the Building, results in the need for additional security for the Premises or the Building, as reasonably determined by Landlord, then any additional security provided by Landlord for the Building or the Premises shall be at Tenant's sole cost and expense, and shall be reimbursed by Tenant to Landlord within five (5) days of written demand. This Section 7.6 shall include, without limitation, any additional security required as a result of labor disturbances, strikes, political protests, dangerous activities, and any other disturbance or disruption of any kind.

7.7 Tenant's Obligations. In performing its obligations under this Section 7, Tenant, at Tenant's expense, shall comply with all Environmental Laws and all other applicable laws, ordinances, codes, orders, rules or regulations of any governmental authority. Tenant shall retain, and shall provide Landlord upon request, copies of Tenant's maintenance and service contract(s) if any. Except as provided in Section 9 in connection with Alterations, and excepting Tenant's right to cure under the Landlord default provisions of Section 19.9, before making or performing any work, repairs, or replacement of any kind in the Premises, if such work shall affect the Building's systems or costs of operation to Landlord then Tenant shall obtain Landlord's prior written approval, which approval may be conditioned on Tenant providing Landlord with plans and specifications therefore, if applicable, which are acceptable to Landlord. All work, maintenance, repairs and replacements by Tenant under this Lease shall be performed by licensed contractors acceptable to Landlord. Tenant shall provide Landlord with copies of all contracts or purchase orders, for such work, maintenance, repairs and replacements prior to having such work, maintenance, repairs or replacements performed. Before installing any heavy equipment or fixtures in the Premises, Tenant shall submit the plans and specifications therefore to Landlord for Landlord's written approval.

7.8 Landlord's Delay for Landlord's Work. Other than as provided in this Section 7.9, Landlord shall have no liability for loss or damage to Tenant resulting in any delay in the Commencement Date, nor shall Tenant have any right to terminate this Lease for Landlord's Delay except as provided herein:

- (a) If Substantial Completion (as defined in Section 5.2 of the Work Letter Agreement, attached hereto as Exhibit C) of Landlord's Work does not occur within 300 days of Execution, which for purposes of this Section 7.9 is defined as the date when the both parties of this Lease have provided a notarized signature (excepting delays caused by Tenant or Force Majeure), Landlord shall pay to Tenant the sum of \$50,000.00;
- (b) If Substantial Completion of Landlord's Work does not occur within 330 days of Execution (except in the event of any Tenant Delay or event of Force Majeure), Landlord shall pay to Tenant the additional sum of \$100,000.00; and
- (c) If Substantial Completion of Landlord's Work does not occur within 360 days of Execution (except in the event of any Tenant Delay or event of Force Majeure), Landlord shall pay to Tenant the additional sum of \$150,000.00.
- (d) In the event Landlord is required to compensate Tenant under this Section 7.9, Tenant may elect to be paid in the form of rent credit, or cash payment, or combination thereof, so long as such sum is credited or paid on or prior to the issuance of a final certificate of occupancy from the City of Tukwila.

(e) In the event Landlord is required to pay Tenant liquidated damages as required by this Section 7.9, and Landlord fails to make such payments to Tenant as set forth herein, or if the Final Certificate of Occupancy has not been issued within 390 days of Execution, Tenant may alternatively elect to terminate this Lease by providing Landlord 14 days notice of termination, in which case this Lease shall terminate without further liability of Landlord or Tenant.

(f) These liquidated damages are not a penalty, but will be assessed against Landlord for failure to complete Tenant Improvements. These liquidated damages amounts are fixed and agreed upon by and between the Landlord and Tenant because of the impracticability and extreme difficulty of fixing and ascertaining the actual damages the Tenant would in such event sustain.

8. ADDITIONAL RENT.

8.1. Definitions. In addition to the Base Rent, Tenant shall pay to Landlord each month as Additional Rent, excluding the capital contribution paid by Tenant for Tenant Improvements, which is subject only to in Section 1.12.1, and excluding Office Space, Tenant's Share of Taxes, Building Operating Costs, Infrastructure Operating Costs, and electrical utility costs as provided in this Section 8 using the following definitions:

8.1.1. Taxes: "Taxes" shall mean taxes on real property and personal property, charges and assessments (or any installments thereof due during the Lease Year) levied with respect to the Property, any improvements, fixtures and equipment on the Property, and all other property of Landlord, real or personal, used directly in the operation of the Property, and any taxes levied or assessed (or any installment thereof due during the Lease Year) in lieu of, in whole or in part, such real property or personal property taxes, or any other tax upon leasing of the Property and/or Building or rents collected, but not including any federal or state income, estate, business and occupation (except to the extent that a rental tax is imposed as a business and occupation tax), inheritance or franchise tax. Any assessment must be paid over the maximum time possible and Tenant shall be responsible only for its pro rata share of the installments, or portions thereof, falling due during the Term.

8.1.2. Infrastructure Operating Costs. "Infrastructure Operating Costs" shall mean all expenses paid or incurred by Landlord for obtaining services and products for maintaining, operating, equipment replacement, and repairing the Shared Infrastructure, including without limitation, the Shared Infrastructure areas, and the personal property used in conjunction therewith, and which shall include, without limitation, depreciation and amortization of capital improvements on a straight-line basis over the useful life of the item in question, with commercially reasonable interest, but only if and to the extent made subsequent to the initial development of the Shared Infrastructure and which are designed with a reasonable probability of enhancing the health and life safety systems of the Shared Infrastructure or improving the operating efficiency of the Shared Infrastructure (and then only in proportion to the anticipated benefit received by Tenant), security services for the Shared Infrastructure, fire alarm system monitoring and testing specific to Shared Infrastructure areas, refuse collection for Shared Infrastructure areas, maintaining water, sewer, storm drainage and other utility systems and services specific to Shared Infrastructure areas, electrical maintenance, which includes repair, maintenance and operations of generator(s) and miscellaneous electrical equipment, mechanical maintenance, which includes repair, maintenance and operations of chiller(s) and miscellaneous mechanical equipment, supplies, Shared Infrastructure area janitorial and cleaning services, services of independent contractors engaged to perform the services of Landlord hereunder, compensation (including employment taxes and fringe benefits) of all persons who perform duties in connection with the operation, maintenance and repair of the Shared Infrastructure, premiums for Landlord's insurance related to the Shared Infrastructure (including applicable interest charges unless Tenant elects to pay its proportionate share of insurance premiums in full when due), commercially reasonable insurance deductibles, licenses, permits and inspection fees, reasonable legal, administrative and accounting expenses, and any other expense or charge whether or not hereinabove described, which in accordance with generally accepted management practices would be considered an expense of maintaining, operating, or repairing the Shared Infrastructure, excluding or deducting, as appropriate costs of any special services rendered to individual tenants (including Tenant). Notwithstanding the foregoing, Infrastructure Operating Costs for 2009 shall be limited to Three and 40/100 Dollars (\$3.40) per square foot per month.

8.1.3. Operating Costs. "Operating Costs" shall mean all expenses other than Taxes and Infrastructure Operating Costs paid or incurred by Landlord for obtaining services and products for maintaining, operating, equipment replacement, and repairing the Property, including without limitation, the Property's public and Common Areas, and the personal property used in conjunction therewith, and which shall include, without limitation:

The costs of Landlord performing its maintenance and repair obligations with respect to the Common Areas and Building under this Lease;

Maintenance, repair and equipment replacement of the Tenant Improvements constructed in accordance with the Work Letter Agreement attached hereto as Exhibit C but excluding maintenance, repair and equipment replacement conducted pursuant to any warranty;

Depreciation and amortization of capital improvements on a straight-line basis over the useful life of the item in question, with reasonable interest, but only if and to the extent made subsequent to the initial development of the Property or Building and which are designed with a reasonable probability of enhancing the health and life safety systems of the Property or improving the operating efficiency of the Property or Building, and then only in proportion to the anticipated benefit received by Tenant;

Security services for the Building or Property, fire alarm system monitoring and testing, refuse collection for the common areas of the Property, maintaining water, sewer, storm drainage and other utility systems and services, Common Area electricity, which may include repair and maintenance on UPS and generator(s), electricity, gas and other similar energy sources (excluding electricity for the Premises which will be charged to the Tenant subject to Section 7.1 above and electricity provided to other leased spaces in the Property), supplies, Common Area janitorial and cleaning services, exterior window washing, landscape planting, maintenance and irrigation, services of independent contractors engaged to perform the services of Landlord hereunder, compensation (including employment taxes and fringe benefits) of all persons who perform duties in connection with the operation, maintenance and repair of the Building and common areas of the Property and its equipment, the maintenance, resurfacing, repair and striping of parking areas and curbs (including driveways, loading zones and access easements), downspouts and gutters, lighting and outdoor facilities, premiums for Landlord's insurance (including applicable interest charges unless Tenant elects to pay its proportionate share of insurance premiums in full when due), commercially reasonable insurance deductibles, licenses, permits and inspection fees, a management fee not to exceed three percent (3%) of the Base Rent charged to Tenant, reasonable legal, administrative and accounting expenses, and any other expense or charge whether or not hereinabove described, which in accordance with generally accepted management practices would be considered an expense of maintaining, operating, or repairing the Property, excluding or deducting, as appropriate costs of any special services rendered to individual tenants (including Tenant). Operating Costs shall not include the following:

(A) Costs of repairs, restoration, replacements or other work occasioned by (1) fire, windstorm or other casualty of an insurable nature (whether such destruction be total or partial) and either (aa) payable (whether paid or not) by insurance required to be carried by Landlord under this Lease, or (bb) otherwise payable (whether paid or not) by insurance then in effect obtained by Landlord, (2) the exercise by governmental authorities of the right of eminent domain, whether such taking be total or partial, (3) the negligence or intentional tort of Landlord, or any subsidiary or affiliate of Landlord, or any representative, employee or agent of same (including the costs of any deductibles paid by Landlord), or (4) the act of any other tenant in the Building, or any other tenant's agents, employees, licensees or invitees to the extent Landlord has the right to recover the applicable cost from such person;

(B) Leasing commissions; attorneys' fees, except for those reasonable attorney's fees in connection with enforcing rules and regulations in the Building; costs disbursements and other expenses incurred in connection with negotiations for leases with tenants, other occupants, or prospective tenants or other occupants of the Building, or similar costs incurred in connection with disputes with tenants, other occupants, or prospective tenants, or similar costs and expenses incurred in connection with negotiations or disputes with consultants, management agents, purchasers or mortgagees of the Building;

(C) Allowances, concessions and other costs and expenses incurred in completing, fixturing, furnishing, renovating or otherwise improving, decorating or redecorating space for tenants (including Tenant), prospective tenants or other occupants and prospective occupants of the Building;

(D) Costs of the initial construction of the Building and repairing, replacing or otherwise correcting substantial defects (but not the costs of repair for normal wear and tear) in the original construction of the Base Building;

(E) Costs or expenses relating to another tenant's or occupant's space which (1) were incurred in rendering any service or benefit to such tenant that Landlord was not required, or were for a service in excess of the service that Landlord was required, to provide Tenant hereunder (including without limitation insurance coverage for another tenant's or occupant's leasehold improvements), or (2) were otherwise in excess of the Building standard Services then being provided by Landlord to all tenants or other occupants in the Building, whether or not such other tenant or occupant is actually charged therefor by Landlord;

(F) Payments of principal and interest or other finance charges made on any debt and rental payments made under any ground or underlying lease or leases;

(G) Costs incurred in connection with the sales, financing, refinancing, mortgaging, selling or change of ownership of the Building, including brokerage commissions, attorneys' and accountants' fees, closing costs, title insurance premiums, transfer taxes and interest charges;

(H) Costs, fines, interest, penalties, legal fees or costs of litigation incurred due to the late payments of taxes, utility bills and other costs incurred by Landlord's failure to make such payments when due;

(I) Costs incurred by Landlord for trustee's fees and partnership organizational expenses;

(J) Landlord's income and franchise taxes, special assessments and other business taxes except those business taxes which relate solely to the operation of the Building and the Property;

(K) All amounts which would otherwise be included in operating expenses which are paid to any affiliate or subsidiaries of Landlord, or any representative, employee or agent of same, to the extent the costs of such services exceed the competitive rates for similar services of comparable quality rendered by persons or entities of similar skill, competence and experience;

(L) Costs or expenses of utilities directly metered to tenants of the Building and payable separately by such tenants;

(M) Increased insurance premiums caused by Landlord's or any other tenant's hazardous acts;

(N) Advertising and promotional costs associated with the leasing of the Building, and costs of signs in or on the Building identifying the owners of the Building or any tenant of the Building;

(O) Costs incurred to correct violations by Landlord of any law, rule, order or regulation which was in effect as of the Lease Effective Date;

(P) Electric power costs for which any tenant directly contracts with the local public service company; or

(Q) Charitable or political contributions.

Landlord shall at all times use its best efforts to operate the Building and Property in an economically reasonable manner as those experienced by other comparable buildings in the Greater Seattle area. Tenant's share of Operating Costs shall be limited to \$.87 per square foot of data center space for 2009.

8.1.4. Tenant's Share. "Tenant's Share" shall mean Tenant's proportionate share of Building Operating Costs, Taxes, and Infrastructure Operating Costs and will vary depending on the cost or expense being allocated.

(a) With respect to Operating Costs attributable to the Building that are primarily variable and are directly associated with and driven by data center tenancy, Tenant's Share shall be the ratio of the occupied raised floor area or server area if not on raised floor in the Premises to the raised floor area or server area if not on raised floor in the entire Building. Operating Costs attributable to the entire Property that are primarily variable and are directly associated with and driven by data center tenancy shall be allocated first to the Building based on the ratio of the total raised floor area of the Building (whether occupied or not) to the total raised floor area of the entire Property (whether occupied or not), and then allocated among the occupants of the Building as provided above.

(b) With respect to Operating Costs that are primarily fixed and do not vary with raised floor occupancy, such as costs of roof maintenance or parking lot maintenance, Tenant's share shall be the ratio of the rentable square footage in the Premises (excluding Office Space) to the rentable square footage in the Building. Such Operating Costs attributable to the entire Property shall first be allocated to the Building based on the ratio of the square footage in the Building to the square footage of the buildings in the Property, and then allocated to occupants of the Building as provided above.

(c) With respect to Taxes and Insurance, Tenant's Share shall be determined by first allocating those costs in the same manner as set forth in Section 8.1.4(a) above.

(d) With respect to Infrastructure Operating Costs, Tenant's Share shall be the ratio of Tenant's reserved UPS unit capacity (initially 750 kW) to the total reserved UPS unit capacity of the Shared Infrastructure.

8.1.5. Tenant's Utility Charges. Landlord and Tenant agree that the cost to provide electricity (including electricity required for cooling) to the Premises is not included in the Base Rent. Landlord will estimate the cost of Tenant's electricity usage utilizing meters installed to monitor the energy usage of Tenant's UPS units. The ratio of Tenant's UPS unit electricity usage to the overall Shared Infrastructure UPS unit usage shall be applied to the overall Shared Infrastructure electricity bill to determine Tenant's share of the Shared Infrastructure electricity bill. Tenant shall pay to the Landlord as Additional Rent each month the Landlord's estimate of such charges as set forth in Section 8.2. At the end of each calendar year the Landlord shall compare the previous 12 months actual charges to its estimates. Any amounts owing shall be paid by Tenant, and credit amounts shall be refunded to Tenant in accordance with Section 8.3. Landlord shall adjust its estimates as provided for in Section 8.3.

8.2. Payment of Additional Rent for Estimated Operating Costs and Taxes. Within thirty (30) days of the Commencement Date or the close of each Lease Year, as applicable, or as soon thereafter as is practicable, Landlord shall provide Tenant with a written statement of Tenant's Share of estimated Building Operating Costs, Taxes, and Infrastructure Operating Costs for such Lease Year. Tenant shall pay 1/12 of the amount of any special or specific Tenant charges, and Tenant's Share of Building Operating Costs, Taxes, and Infrastructure Operating Costs as Additional Rent as provided in Section 4 each month during such Lease Year and until such time as Landlord provides Tenant with a statement of estimated Building Operating Costs, Taxes and Infrastructure Operating Costs for the subsequent Lease Year. If at any time or times during such Lease Year, it appears to Landlord that Tenant's Building Operating Costs, Taxes and Infrastructure Operating Costs will vary from the estimated Building Operating Costs, Taxes and Infrastructure Operating Costs by more than five percent (5%) on an annual basis, Landlord may, by written notice to Tenant, revise its estimate for such Lease Year and Additional Rent payable by Tenant under this Section 8 for such Lease Year shall be increased or decreased based on Landlord's revised estimate.

8.3. Reconciliation. Landlord will make reasonable efforts within ninety (90) days after the close of each Lease Year during the Term hereof for which an estimated statement was delivered to Tenant pursuant to Section 8.2, to deliver to Tenant a written statement ("Reconciliation Statement") setting forth Tenant's actual Building Operating Costs, Taxes and Infrastructure Operating Costs paid or incurred by Landlord during the preceding Lease Year (or such prorated portion of such Lease Year if this Lease commences or terminates on a day other than the first or last day of a Lease Year, based on a 365-day Lease Year). If the actual Building Operating Costs, Taxes and Infrastructure Operating Costs shown on the Reconciliation Statement for any Lease Year exceed estimated Building Operating Costs, Taxes and Infrastructure Operating Costs paid by Tenant to Landlord pursuant to Section 8.3, Tenant shall pay the excess to Landlord as Additional Rent within thirty (30) days after the date of the Reconciliation Statement. If the Reconciliation Statement shows that actual Building Operating Costs, Taxes and Infrastructure Operating Costs are less than the estimated Building Operating Costs, Taxes and Infrastructure Operating Costs paid by Tenant to Landlord pursuant to Section 8.3, then the amount of such overpayment shall be credited by Landlord to the next Additional Rent payable by Tenant (or refunded to Tenant in the event of the termination or expiration of this Lease).

8.4. Determinations. The determination of actual and estimated Building Operating Costs, Taxes and Infrastructure Operating Costs shall be made by Landlord. Landlord or its agent shall keep records in reasonable detail showing all expenditures made for the items enumerated in this Section 8.

Tenant shall have the right at its own cost and expense to review and/or inspect Landlord's records once in any calendar year with respect to any Building Operating Costs, Taxes and Infrastructure Operating Costs shown on Landlord's annual reconciliation statement provided to Tenant. This review/inspection right is limited solely to the prior calendar year based upon the date Tenant provides written notice to Landlord. Tenant shall give Landlord written notice ("Tenant's Notice") of its intention to conduct any such review or inspection on or before thirty (30) days after the date of Tenant's receipt of Landlord's annual reconciliation statement. Tenant's review/inspection shall be conducted by a certified public accounting firm at Landlord's main business office, or at such other location as Landlord may keep its relevant business records, and on a date mutually agreed upon by Landlord and Tenant, but in no event is Landlord required to agree to a date which is earlier than sixty (60) days from the date of Tenant's Notice to Landlord. Landlord agrees that it shall give Tenant said access to review/inspect the business records no later than seventy-five (75) days after Tenant's Notice to Landlord. Tenant must provide written notice to Landlord within one hundred twenty (120) days after Tenant's Notice to Landlord, specifying any and all claims it may have determined in good faith. Tenant agrees to diligently pursue its review/inspection of Landlord's records in order to determine if it concurs or disagrees with Landlord's statement.

Tenant shall be deemed to have waived its review and inspection right, and therefore agree with Landlord's changes, with respect to the period of time covered in Landlord's annual reconciliation statement if any of the following occurs:

Tenant has not notified Landlord in writing on or before thirty (30) days after Tenant's receipt of Landlord's annual reconciliation statement of its intention to conduct its review/inspection,

Tenant has not commenced its review/inspection of Landlord's records at Landlord's office or designated location on or before ninety (90) days after Tenant's Notice to Landlord,

Tenant has not provided written notice to Landlord on or before one hundred twenty (120) days after Tenant's Notice of review/inspection to Landlord, specifying any and all claims it may have determined in good faith.

Except as required by the Washington Public Records Act, ch. 42.56 RCW, and other applicable law, the information and results of any inspection conducted by or on behalf of Tenant shall be kept confidential by Tenant, and the results shall be provided to Landlord within ten (10) business days after the completion of the inspection. All such inspection(s) shall be at the sole cost and expense of Tenant, provided that in the event Tenant's review reasonably determines there is an overcharge of Operating Expenses which has not been credited to Tenant, said overcharge being more than five percent (5%) of Tenant's share of the Operating Expenses, and Landlord does not contest the Tenant's results, then Landlord shall pay Tenant's reasonable out-

of-pocket costs of such inspection, not to exceed Two Thousand Dollars (\$2,000). If Landlord desires to contest the result of Tenant's inspection, Landlord may do so within ten (10) business days of its receipt of the inspection results, by submitting the results of the inspection to binding arbitration administered by the American Arbitration Association in accordance with its Commercial Arbitration Rules, to be conducted by a mutually acceptable single arbitrator with not less than ten (10) years experience as a real estate attorney, or a retired judge with experience in commercial real estate litigation and/or leases. Any overcharge or undercharge determined as a result of Tenant's inspection or by the arbitrator shall be paid by the appropriate party to the other within thirty (30) days after the inspection results are provided to Landlord. In the case of arbitration, the non-prevailing party shall pay to the prevailing party all attorneys fees and costs as provided in Section 24 of this Lease. Nothing in this paragraph shall relieve Tenant of its obligation under Section 8 to pay Additional Rent without notice, demand, offset or deduction.

8.5. Tenant's Personal Property Taxes. To the extent Tenant is required to pay Personal Property Taxes, Tenant shall pay prior to delinquency all such taxes payable with respect to all Property of Tenant located on the Premises or the Property and, upon Landlord's request, shall promptly provide Landlord with written proof of such payment or provide Landlord with the applicable tax exemption. Solely for purposes of this Section 8.6, "Property of Tenant" shall include Landlord's Work, Tenant's Work, Tenant's Equipment, including the Data System and all other improvements which are paid for by Tenant, and "Personal Property Taxes" shall include all property taxes assessed against the Property of Tenant, whether assessed as real or personal property.

9. IMPROVEMENTS AND ALTERATIONS BY TENANT. Tenant shall not make any changes, alterations, additions or improvements in or to the Premises ("Alterations"), including, without limitation, changes to locks on doors or to cages and wiring, subject to the provisions of Section 19.9 (Default by Landlord), without first obtaining the written consent of Landlord and, where required by Landlord, such Alterations shall be made under the supervision of a competent architect and/or a licensed structural engineer, and in accordance with plans and specifications which meet current building standards for quality and design, approved by Landlord, which approval shall not be unreasonably withheld. All work with respect to any Alterations shall be done in a good and workmanlike manner and shall be diligently prosecuted to completion. In no event shall Tenant's Alterations change or affect the strength, exterior appearance, roof, or the mechanical, electrical, or plumbing services or systems, of the Building without Landlord's consent. Tenant shall reimburse Landlord upon demand for any reasonable sums expended by Landlord for examination and approval of plans and specifications for any and all Alterations. Tenant shall also pay Landlord a sum equal to the reasonable costs incurred by Landlord during any inspection or supervision of any and all Alterations. All damages or injury to the Property caused by any act or omission of Tenant, or Tenant's officers, contractors, agents, invitees, licensees or employees, or by any persons who may be in or upon the Property with the express or implied consent of Tenant, including but not limited to, damage from cracked or broken glass in windows or doors, shall be paid by Tenant upon demand by Landlord.

10. ACCESS. Landlord may restrict access to the Building in accordance with the Building's security system. Tenant shall have at all times during the Lease Term (24 hours of all days) reasonable access to the Premises. Landlord, at Tenant's cost, shall provide Tenant with security access cards to the Building as such cards are a part of the Building's security system (it is recommended that Tenant keep such cards to a maximum of five (5), however Tenant may designate as many people they choose to receive the cards). Tenant shall permit Landlord and its agents to enter the Premises at all reasonable times (except in cases of emergency) for the purpose of inspecting or improving the Premises or the Building, upon advance notice to Tenant, or for performing any of its obligations under this Lease. Nothing contained in this Section 10 shall be deemed to impose any obligation upon Landlord not expressly stated elsewhere in this Lease. When reasonably necessary Landlord may temporarily close entrances, doors, corridors, elevators or other facilities without liability to Tenant by reason of such closure and without such action by Landlord being construed as an eviction of Tenant or release of Tenant from the duty of observing and performing any of the provisions of this Lease, so long as such action does not materially and unreasonably interfere with Tenant's access to the leased Premises. Landlord shall have the right to enter the Premises for the purpose of showing the Premises to prospective tenants within the period of one hundred eighty (180) days prior to the expiration or sooner termination of the Lease Term.

Landlord shall have the right at all times to enter the Premises, with reasonable notice to Tenant, for the purpose of showing the Premises to prospective purchasers or lenders.

11. DAMAGE OR DESTRUCTION.

11.1. Damage and Repair. If the Building is damaged by fire or any other cause to such extent that the cost of restoration, as estimated by Landlord, will equal or exceed thirty percent (30%) of the replacement value of the Building (exclusive of foundations) just prior to the occurrence of the damage, or if insurance proceeds sufficient for restoration are for any reason unavailable, then Landlord may no later than the one hundred twentieth (120th) day following the damage, give Tenant a notice of its election to terminate this Lease. In the event of such election; (a) this Lease shall be deemed to terminate on the date that is thirty (30) days from the date of Tenant's receipt of such notice ("Termination Date"); (b) Tenant shall surrender possession of the Premises on the Termination Date; (c) Rent, Additional Rent and any unamortized over the initial Term of this Lease capital contribution for Tenant Improvements shall be apportioned as of the date of Tenant's surrender and any Rent or capital contribution for Tenant Improvements paid for any period beyond such date shall be repaid to Tenant; and (d) any insurance proceeds paid to Tenant as a result of Tenant's insurance obligations in Section 14.3 shall be paid to Landlord, but only in an amount calculated on a pro rata monthly basis from the date of termination under this Section 11.1 and extending to the Expiration Date.

If the cost of restoration as estimated by Landlord shall amount to less than thirty percent (30%) of said replacement value of the Building and insurance proceeds sufficient for restoration are available, or if Landlord does not elect to terminate this Lease, Landlord shall restore the Building and the Premises to the extent of the improvements to the Premises originally provided by Landlord hereunder, including improvements made by Landlord pursuant to the Work Letter Agreement attached hereto as Exhibit C, and subject to Landlord's receipt of insurance proceeds from Tenant based on Section 14.3, but in all instances limited to a pro rata share based on the remaining time between the date of the damaging event and the Expiration Date, but excluding any improvements made by Tenant, with reasonable promptness, subject to delays beyond Landlord's control and delays in the making of insurance adjustments by Landlord, and Tenant shall have no right to terminate this Lease except as provided in this Section 11.

If this Lease is terminated as a result of damage or destruction, then all insurance proceeds from Tenant's insurance policy on improvements made by Tenant shall be paid to Landlord. To the extent that the Premises are rendered untenable by such damage or by Landlord's restoration work under this Section, the Base Rent, Additional Rent, provided, however, in the event such damage resulted from or was contributed to, directly or indirectly, by the act, fault or neglect of Tenant, Tenant's officers, contractors, agents, employees, invitees or licensees, Base Rent and Additional Rent shall abate only to the extent Landlord receives proceeds from any rental income insurance policy received by Landlord for loss of Rent under this Lease.

11.2. Destruction During Last Year of Term. Notwithstanding anything to the contrary in this Lease, in case the Building shall be substantially destroyed by fire or other cause at any time during the last Lease Year of this Lease, or the last year of any subsequent Renewal Term described in Section 3.3, either Landlord or Tenant may terminate this Lease upon written notice to the other given within thirty (30) days of the date of such destruction.

11.3. Business Interruption. No damages, compensation or claim shall be payable by Landlord for inconvenience, loss of business or annoyance arising from any damage or destruction, repair or restoration of any portion of the Premises or the Building. Landlord shall use commercially reasonable efforts to make such repairs promptly.

11.4. Tenant Improvements. Except for the Shared Infrastructure, Landlord will not carry insurance of any kind on Tenant's furniture, furnishings, fixtures, equipment, including the Data System and Tenant's Equipment, or appurtenances of Tenant under this Lease and Landlord shall not be obligated to repair any damage thereto or replace the same. Tenant shall insure its improvements in accordance with Section 14.3 and proceeds of such insurance shall be used in any repair or restoration of the Premises and shall pay its pro rata share of the cost of insuring the Shared Infrastructure.

11.5. **Express Agreement.** The provisions of this Section 11 shall be considered an express agreement governing any case of damage or destruction of the Building or Premises by fire or other casualty.

12. **WAIVER OF SUBROGATION.** Whether loss or damage is due to the negligence of either Landlord or Tenant, their agents or employees, or any other cause, Landlord and Tenant do each hereby release and relieve the other, their agents or employees, from responsibility for, and waive their entire claim of recovery for any loss or damage to the real or personal property of either party located anywhere on the Property, including the Building itself, arising out of or incident to the occurrence of any of the perils which are covered, or are required to be covered under this Lease, by their respective property and related insurance policies. Each party shall use best efforts to cause its insurance carriers to consent to the foregoing waiver of rights of subrogation against the other party. Notwithstanding the foregoing, no such mutual release shall be effective unless and to the extent the aforesaid insurance policy or policies shall expressly permit such a release or contain a waiver of the carrier's right to be subrogated.

13. **INDEMNIFICATION.** Landlord shall not be liable for, and Tenant shall defend (unless Landlord waives its right to such defense, and in any event with counsel reasonably satisfactory to Landlord), indemnify, hold harmless and protect Landlord and its employees and agents from any claim, demand, liability, judgment, award, fine, mechanics' lien or other lien, loss, damage, expense, penalty, charge or cost of any kind or character (including reasonable attorney fees and court costs) which may be made, incurred or asserted by Tenant, Tenant's agents or employees, contractors, or any third parties (including but not limited to Landlord's agents, servants or employees), to the extent caused by: (a) any labor dispute involving Tenant or its agents or contractors (but excluding labor disputes involving Landlord or its contractors, subcontractors, or agents); (b) the construction, repair, alteration, improvement, use, occupancy or enjoyment of the Premises by Tenant its contractors, agents, employees and/or customers, licensees, or invitees; (c) injury to, or death of, any person or persons or damage to, or destruction of, any property occurring in, on or about the Premises (d) Tenant's breach of this Lease; (e) infringement or misappropriation of any intellectual property rights, defamation, libel, slander, obscenity, pornography, or violation of the rights of privacy or publicity or spamming, or any other offensive, harassing or illegal conduct by Tenant or its agents, employees, contractors, agents, invitees or licensees arising from the use of the Premises or the equipment located therein; or (f) Tenant's network or its subcontractor's systems security is breached, including implantation or spread of viruses, malicious acts, denial of service attacks, information theft, unauthorized access or use, and other computer crimes by Tenant or its agents, employees, contractors, agents, invitees or licensees, customers, arising from the use of the Premises or the equipment located therein (the "Claims"). Notwithstanding anything to the contrary in this Section 13, nothing in this Section 13 shall relieve Landlord from responsibility for its proportionate share of its fault attributable to the negligence or willful misconduct of Landlord or its agents or contractors in causing any such Claims and nothing shall require the defense, indemnification, or holding harmless of Landlord by Tenant to the extent such claims result from the negligence or willful misconduct of Landlord or its agents or contractors. **TENANT HEREBY WAIVES ITS IMMUNITY WITH RESPECT TO LANDLORD ONLY, UNDER THE INDUSTRIAL INSURANCE ACT (RCW TITLE 51) AND/OR THE LONGSHOREMEN'S AND HARBOR WORKER ACT, AND/OR ANY EQUIVALENT ACTS AND TENANT EXPRESSLY AGREES TO ASSUME POTENTIAL LIABILITY FOR ACTIONS BROUGHT AGAINST LANDLORD BY TENANT'S EMPLOYEES. THIS WAIVER HAS BEEN SPECIFICALLY NEGOTIATED BY THE PARTIES TO THIS LEASE AND TENANT HAS HAD THE OPPORTUNITY TO, AND HAS BEEN ENCOURAGED TO, CONSULT WITH INDEPENDENT COUNSEL REGARDING THIS WAIVER.**

Tenant shall, at its sole cost and expense, indemnify, defend and hold harmless Landlord and Landlord's subsidiaries and parent corporations, shareholders, members, managers, directors, officers, employees, partners, affiliates, and agents from, any claims, liabilities, costs or expenses incurred or suffered arising in connection with any Hazardous Materials which are brought on the Premises or the Property by Tenant, Tenant's employees, agents, vendors, visitors or contractors. Tenant's indemnification, defense, and hold harmless obligations include, without limitation, the following: (i) claims, liability, costs or expenses resulting from or based upon administrative, judicial (civil or criminal) or other action, legal or equitable, brought by any private or public person under common law or under the Comprehensive Environmental Response, Compensation

and Liability Act of 1980 as amended ("CERCLA"), the Resource Conservation and Recovery Act of 1980 ("RCRA") or any other Federal, State, County, or Municipal law, ordinance, or regulation now or hereafter in effect; (ii) claims, liabilities, costs or expenses pertaining to the indemnification, monitoring, clean-up, containment or removal of Hazardous Materials from soils, riverbeds or aquifers including the provision of an alternative public drinking water source; (iii) all costs of defending such claims; and (iv) all other liabilities, obligations, penalties, fines, claims, actions (including remedial or enforcement actions of any kind and administrative or judicial proceedings, orders or judgments), damages (including consequential and punitive damages), and costs (including attorney, consultant, and expert fees and expenses) resulting from the release or violation. This indemnity shall survive the expiration or termination of this Lease.

Tenant shall not be liable for, and Landlord shall defend (unless Tenant waives its right to such defense, and in any event with counsel reasonably satisfactory to Tenant), indemnify, hold harmless and protect Tenant and its employees and agents from any claim, demand, liability, judgment, award, fine, mechanics' lien or other lien, loss, damage, expense, penalty, charge or cost of any kind or character (including reasonable attorneys' fees and court costs) which may be made, incurred or asserted by Landlord, Landlord's agents or employees, contractors, or any third parties (including but not limited to Tenant's agents, servants or employees), to the extent caused by: (a) any labor dispute involving Landlord or its agents or contractors (but excluding labor disputes involving Tenant or its contractors, subcontractors, or agents); (b) the construction, repair, alteration, improvement, use, occupancy or enjoyment of the Building by Landlord its contractors, agents, employees and/or customers, licensees, or invitees; (c) injury to, or death of, any person or persons or damage to, or destruction of, any property occurring in, on or about the Premises to the extent caused by Landlord's contractors, agents, employees and/or customers, licensees, or invitees; or (d) Landlord's breach of this Lease (the "Claims"). Notwithstanding anything to the contrary in this Section 13, nothing in this Section 13 shall relieve Tenant from responsibility for its proportionate share of its fault attributable to its negligence or willful misconduct in causing any such Claims. LANDLORD HEREBY WAIVES ITS IMMUNITY WITH RESPECT TO TENANT ONLY, UNDER THE INDUSTRIAL INSURANCE ACT (RCW TITLE 51) AND/OR THE LONGSHOREMEN'S AND HARBOR WORKER ACT, AND/OR ANY EQUIVALENT ACTS AND LANDLORD EXPRESSLY AGREES TO ASSUME POTENTIAL LIABILITY FOR ACTIONS BROUGHT AGAINST TENANT BY LANDLORD'S EMPLOYEES. THIS WAIVER HAS BEEN SPECIFICALLY NEGOTIATED BY THE PARTIES TO THIS LEASE AND LANDLORD HAS HAD THE OPPORTUNITY TO, AND HAS BEEN ENCOURAGED TO, CONSULT WITH INDEPENDENT COUNSEL REGARDING THIS WAIVER.

Landlord shall, at its sole cost and expense, indemnify, defend and hold harmless Tenant and Tenant's elected officials, directors, officers, employees, and agents from, any claims, liabilities, costs or expenses incurred or suffered arising in connection with any Hazardous Materials which are brought on the Premises or the Property by Landlord, Landlord's employees, agents, vendors, visitors or contractors. Landlord's indemnification, defense, and hold harmless obligations include, without limitation, the following: (i) claims, liability, costs or expenses resulting from or based upon administrative, judicial (civil or criminal) or other action, legal or equitable, brought by any private or public person under common law or under the Comprehensive Environmental Response, Compensation and Liability Act of 1980 as amended ("CERCLA"), the Resource Conservation and Recovery Act of 1980 ("RCRA") or any other Federal, State, County, or Municipal law, ordinance, or regulation now or hereafter in effect; (ii) claims, liabilities, costs or expenses pertaining to the indemnification, monitoring, clean-up, containment or removal of Hazardous Materials from soils, riverbeds or aquifers including the provision of an alternative public drinking water source; (iii) all costs of defending such claims; and (iv) all other liabilities, obligations, penalties, fines, claims, actions (including remedial or enforcement actions of any kind and administrative or judicial proceedings, orders or judgments), damages (including consequential and punitive damages), and costs (including attorney, consultant, and expert fees and expenses) resulting from the release or violation. This indemnity shall survive the expiration or termination of this Lease.

14. INSURANCE.

14.1. Worker's Compensation. Commencing on the earlier of the

Commencement Date or the date Tenant first enters onto the Premises and continuing throughout the Term of this Lease and any renewal hereof, Tenant shall, at its own expense, keep and maintain in full force and effect all required worker's compensation coverages, including employer's liability at a limit of not less than One Million Dollars (\$1,000,000).

14.2. Liability Insurance. Commencing on the earlier of the Commencement or the date Tenant first enters onto the Premises, Tenant shall, throughout the Term of this Lease and any renewal hereof, at its own expense, keep and maintain in full force and effect, a policy of commercial general liability insurance on an occurrence form, at least as broad as Insurance Services Office form CG00 01 current edition insuring activities upon, in or about the Premises or the Building against claims of injury to persons including death and property damage with a combined single limit of not less than Five Million Dollars (\$5,000,000) per occurrence and Five Million Dollars (\$5,000,000) in the aggregate. General aggregate shall apply on a per location basis.

14.3. Property Insurance. Tenant shall, throughout the Term of this Lease and any renewal hereof, at its own expense, keep and maintain in full force and effect special form perils coverage, including business interruption insurance with limits of liability representing at least one (1) year of rent on Tenant's furniture, furnishings, fixtures, personal property, and equipment, and on any improvements and alterations to the Premises made by Tenant, including without limitation, any improvements made by Landlord pursuant to the Landlord's Work contained in Exhibit C and attached hereto and on all Tenant's furniture, furnishings, fixtures, equipment and appurtenances, including the Data System and Tenant's Equipment, at one hundred percent (100%) of the current replacement cost value on an agreed amount basis

Landlord is not required to carry insurance of any kind on Tenant's furniture, furnishings, fixtures, personal property, and equipment and on any improvements and alterations to the Premises made by Tenant, including without limitation, any improvements made by Landlord on behalf of Tenant pursuant to a Tenant allowance or credit under this Lease and Landlord shall not be obligated to repair any damage thereto or replace the same.

Landlord shall maintain at its expense all risk property insurance on the building, appurtenances, fixtures and equipment other than property for which Tenant is responsible at one hundred percent (100%) of the current replacement cost value or an agreed amount basis.

14.4. Automobile Liability Insurance Requirements. Tenant shall maintain automobile coverage with a combined single limit of not less than One Million Dollars (\$1,000,000). Coverage shall apply to any owned, non-owned or hired automobiles.

14.5. Insurance Policy Requirements. All policies of insurance required under this Section 14 shall be with companies reasonably approved by Landlord. No insurance policy required under this Section 14 shall be cancelled or reduced in coverage except after forty-five (45) days (ten (10) days for non-payment of premium) prior written notice to Landlord. All insurers shall have a Best's rating of AV or better. The property and liability policies required under this Section 14 shall be written as primary policies and not contributing to or in excess of any coverage Landlord may choose to maintain. Tenant shall make available for inspection by Landlord prior to occupancy or entrance onto the Premises and at least annually thereafter, at the King County offices of Risk Management, copies of policies of such insurance or certificates with endorsement, evidencing the existence of the minimum required insurance. In no event shall the limits of any insurance policy required under this Section 14 be required under this Section 14 be considered as limiting the liability of Tenant under this Lease.

In no event shall the limits or coverages required to be carried be considered as necessarily adequate nor limiting the liability of Tenant under this Lease.

14.6. Self-Insurance. Landlord hereby consents to Tenant's right to comply with and satisfy the obligations contained in this Section 14 as to maintenance of policies of insurance by acting as a self-insurer as to the applicable insurance coverage, King County, a charter county government under the constitution of the State of Washington, hereinafter referred to as "Tenant", maintains a fully funded Self-Insurance program as defined in King County Code

4.12 for the protection and handling of the County's liabilities including injuries to persons and damage to property.

Landlord acknowledges, agrees and understands that the Tenant is self-funded for all of its liability exposures. The Tenant agrees, at its own expense, to maintain, through its self-funded program, coverage for all of its liability exposures for this Lease Agreement. The Tenant agrees to provide the Landlord with at least 30 days prior written notice of any material change in the County's self-funded program and will provide the Landlord with a certificate of self-insurance as adequate proof of coverage. Landlord further acknowledges, agrees and understands that the Tenant does not purchase Commercial General Liability insurance and is a self-insured governmental entity; therefore the Tenant does not have the ability to add the Landlord as an additional insured.

Should the Tenant elect to cease self-insuring its liability exposures and purchase Commercial General Liability insurance, Tenant agrees to add the Landlord as an additional insured and comply with Section 14 above.

14.7. Failure to Maintain Insurance. If Tenant fails to maintain its self-insurance program described above and fails or refuses to purchase and maintain any insurance required in Section 14, Landlord may, at its option, procure insurance for Landlord's benefit and/or interests and any and all reasonable premiums paid by Landlord therefore shall be deemed Additional Rent and shall be due on demand. Landlord will not be responsible to procure insurance for Tenant's interests and/or benefit.

14.8. Increased Insurance Costs. Tenant shall not keep, use, sell or offer for sale in or upon the Premises, nor conduct any operation, which may be prohibited by Landlord's insurance carriers. Tenant shall pay any increase in premiums for property and liability insurance that may be charged during the Lease Term on the amount of such insurance which may be carried by Landlord on the Premises or the Building or Buildings of which they are a part, resulting from Tenant's occupancy or from the type of merchandise which Tenant stores or sells on the Premises, whether or not Landlord has consented thereto. In determining whether increased premiums are the result of Tenant's use of the Premises, rates and/or premiums determined by the organization and/or underwriter setting the insurance rates and/or charges on the Premises or Building or Buildings of which they are a part shall be conclusive evidence of the several items and charges which make up the insurance premium. Landlord shall deliver bills for such additional premiums to Tenant at such times as Landlord may elect, and Tenant shall immediately reimburse Landlord therefore.

15. ASSIGNMENT AND SUBLETTING.

15.1. Assignment or Sublease. Tenant shall not assign, mortgage, encumber or otherwise transfer this Lease, sublet the whole or any part of the Premises, or allow any third party to use the Premises, without in each case first obtaining Landlord's prior written consent, which consent may not be unreasonably conditioned, delayed or withheld. Tenant also acknowledges that any right of first refusal, option to extend the Term of this Lease, terminate this Lease, or any other options which Landlord has granted herein are particular to Tenant and are not assignable or transferable to any assignee or sublessee under this Lease and will terminate upon any such assignment, transfer, sublease or other grant of occupancy rights with respect to the Premises, except to a Permitted Assignee.

In no event shall an assignment, subletting or other transfer of the Lease relieve Tenant of any of its obligations under this Lease. Consent to any such assignment, subletting or transfer shall not operate as a waiver of the necessity for consent to any subsequent assignment, subletting or transfer.

If Tenant is a corporation, any transfer of this Lease by merger, consolidation or liquidation, or any change in the ownership of a majority of its outstanding voting stock, or power to vote a majority of its outstanding voting stock, shall constitute an assignment for the purpose of this Section 15; provided, however, for the purposes of this Section 15, a public offering of stock registered with the SEC, shall not constitute a transfer. If Tenant is a partnership, limited liability company, or other entity, any transfer of this Lease by merger, consolidation, liquidation, dissolution, or any change in the ownership of a majority of the ownership and/or economic interests shall constitute an assignment for the purpose of this Section 15.

Tenant shall have the right, without Landlord's consent, to sublet or assign the Premises or any part thereof to any subsidiary of Tenant or to any entity which controls or is under the common control of Tenant ("Permitted Assignee"). Furthermore, provided that the successor to Tenant resulting from a merger, consolidation or other corporate restructuring has a net worth of equal or greater value to Tenant just prior to such merger, consolidation or other corporate restructuring, Landlord's consent to any such subletting or assignment shall not be required. Tenant may also allow any person or company which is a client and/or customer of Tenant or which is providing service to Tenant or one of Tenant's clients (i.e., service level, outsourcing and/or management) to occupy, use and/or operate from certain portions of the Premises without such occupancy, use or operation being deemed an assignment or subleasing as long as no new demising walls are constructed to accomplish such occupancy, use and/or operation and as long as such relationship was not created as a subterfuge to avoid the obligations set forth in the Sublease provisions of the Lease document.

15.2. Documentation and Expenses. In connection with each request for an assignment or subletting Tenant shall: (i) submit in writing to Landlord the name and legal composition of the proposed subtenant or assignee, the nature of the proposed subtenant's or assignee's business to be carried on in the Premises, the terms and provisions of the proposed sublease or assignment and such reasonable financial information as Landlord may request concerning the proposed subtenant or assignee; and (ii) pay Landlord's reasonable costs of processing such assignment or subletting, including attorneys' fees, upon demand of Landlord. Tenant shall provide Landlord with copies of all assignments, subleases and assumption instruments.

15.3. Transferee Obligations. As a condition to Landlord's approval of an assignment, any potential assignee otherwise acceptable to Landlord shall assume, in writing, all of Tenant's obligations under this Lease and Tenant and such assignee shall agree, in writing, to be jointly and severally liable for the performance of all of Tenant's obligations under this Lease. As a condition to Landlord's approval, any sublessee otherwise acceptable to Landlord shall assume, in writing, all of Tenant's obligations under this Lease as to the subleased portion of the Premises and Tenant and such sublessee shall agree, in writing, to be jointly and severally liable with Tenant for Rent and performance of all of the terms, covenants, and conditions of such approved sublease. If an assignment or sublease is consented to by Landlord, then the Tenant shall pay all costs incurred in connection therewith (including any lease commissions and lease concessions), and the assignment or sublease shall state that all payments from the assignee or sublessee shall be paid directly to Landlord. In connection with a permitted assignment or sublease, so long as the Tenant is not in default under this Lease, Landlord shall grant to Tenant a credit against the monthly rental due under this Lease in the amount of the rental actually received by Landlord under the assignment or sublease for that month, calculated on a per square foot basis, and based upon the portion of the Premises covered by the assignment or sublease. The maximum credit for any month under this subsection (a) shall be equal to the per square foot rental due under this Lease. (By way of example only, if the then applicable monthly rental under this Lease is \$2.50 per square foot, and there is a sublease providing for monthly rental of \$2.75 per square foot, then the maximum monthly credit under this subsection (a) shall be \$2.50 per square foot times the number of square feet covered by the sublease, and with the credit being applicable only once the payment is received by Landlord from the sublessee.) If in any month Tenant is entitled to a credit under this subsection (a), but the credit arises after the Tenant has paid in full the rental due under this Lease for that month, then Landlord shall pay the amount of the credit within five (5) business days after the date that the payment is received by Landlord from the assignee or sublessee.

16. SIGNS. Tenant shall not inscribe any inscription, or post, place, or in any manner display any sign, graphics, notice, picture, placard or poster, or any advertising matter whatsoever, anywhere in or about the Property at places visible (either directly or indirectly as an outline or shadow on a glass pane) from anywhere outside the Premises without first obtaining Landlord's written consent, such consent to be at Landlord's sole discretion. Any such consent by Landlord shall be upon the understanding and condition that Tenant shall remove the same at the expiration or sooner termination of this Lease and Tenant, at its expense, shall repair any damage to the Property, or any portion thereof, caused by such removal. Notwithstanding the foregoing, if Tenant is permitted to place signage on the Building such signage must be pre-approved by Landlord's architect and must comply with local laws. The cost of such signage, maintenance, repair and operation shall be borne exclusively by Tenant.

17. LIENS. Tenant has no authority to allow any liens to be placed against the Property. Tenant shall keep its interest in this Lease, any property of Tenant located on the Property, and the Property free from any liens arising out of any work performed or materials ordered or obligations incurred by or on behalf of Tenant and Tenant hereby agrees to indemnify, defend and hold Landlord harmless from and against any liability from any such lien, including without limitation, liens arising from Tenant's Work. In the event any lien is filed against the Property, or any portion thereof, by any person claiming by, through or under Tenant, Tenant shall, upon request of Landlord and at Tenant's expense, immediately either cause such lien to be released of record or furnish to Landlord a bond, in form and amount and issued by a surety, satisfactory to Landlord, indemnifying Landlord and the Property against all liability, costs and expenses, including attorneys' fees, which Landlord may incur as a result thereof. Provided that such bond has been furnished to Landlord, Tenant, at its sole cost and expense and after written notice to Landlord, may contest, by appropriate proceedings conducted in good faith and with due diligence, any lien, encumbrance or charge against the Property arising from work done or materials provided to and for Tenant, if, and only if, such proceedings suspend the collection thereof against Landlord, Tenant and the Property and neither the Property nor any part thereof or interest therein is or will be, in Landlord's sole judgment, in any danger of being sold, forfeited or lost.

18. BANKRUPTCY.

18.1. Assumption of Lease. In the event Tenant becomes a Debtor under Chapter 7 of the Bankruptcy Code ("Code") or a petition for reorganization or adjustment of debts is filed concerning Tenant under Chapters 11 or 13 of the Code, or a proceeding is filed under Chapter 7 of the Code and is transferred to Chapters 11 or 13 of the Code, the Trustee or Tenant, as Debtor and as Debtor-In-Possession, may not elect to assume this Lease unless, at the time of such assumption, the Trustee or Tenant has cured all defaults under the Lease and paid all sums due and owing under the Lease or provided Landlord with "Adequate Assurance" (as defined below) that: (i) within ten (10) days from the date of such assumption, the Trustee or Tenant will completely pay all sums due and owing under this Lease and compensate Landlord for any actual pecuniary loss resulting from any existing default or breach of this Lease, including without limitation, Landlord's reasonable costs, expenses, accrued interest, and attorneys' fees incurred as a result of the default or breach; (ii) within twenty (20) days from the date of such assumption, the Trustee or Tenant will cure all non-monetary defaults and breaches under this Lease, or, if the nature of such non-monetary defaults is such that more than twenty (20) days are reasonably required for such cure, that the Trustee or Tenant will commence to cure such non-monetary defaults within twenty (20) days and thereafter diligently prosecute such cure to completion; and (iii) the assumption will be subject to all of the provisions of this Lease.

18.1.1. Definition of Adequate Assurances. For purposes of this Section 18, Landlord and Tenant acknowledge that in the context of a bankruptcy proceeding involving Tenant, at a minimum, "Adequate Assurance" shall mean: (i) the Trustee or Tenant has and will continue to have sufficient unencumbered assets after the payment of all secured obligations and administrative expenses to assure Landlord that the Trustee or Tenant will have sufficient funds to fulfill the obligations of Tenant under this Lease; and (ii) the Bankruptcy Court shall have entered an Order segregating sufficient cash payable to Landlord and/or the Trustee or Tenant shall have granted a valid and perfected first lien and security interest and/or mortgage in or on property of Trustee or Tenant acceptable as to value and kind to Landlord, to secure to Landlord the obligation of the Trustee or Tenant to cure the monetary and/or non-monetary defaults and breaches under this Lease within the time periods set forth above; and (iii) the Trustee or Tenant, at the very minimum, shall deposit a sum equal to two (2) month's Base Rent to be held by Landlord (without any allowance for interest thereon) to secure Tenant's future performance under the Lease.

18.2. Assignment of Lease. If the Trustee or Tenant has assumed the Lease pursuant to the provisions of this Section 18 for the purpose of assigning Tenant's interest hereunder to any other person or entity, such interest may be assigned only after the Trustee, Tenant or the proposed assignee have complied with all of the terms, covenants and conditions of this Lease, including, without limitation, those with respect to Additional Rent. Landlord and Tenant acknowledge that such terms, covenants and conditions are commercially reasonable in the context of a bankruptcy proceeding of Tenant. Any person or entity to which this Lease is assigned pursuant to the provisions of the Code shall be deemed without further act or deed to have assumed

all of the obligations arising under this Lease on and after the date of such assignment. Any such assignee shall upon request execute and deliver to Landlord an instrument confirming such assignment.

18.3. Adequate Protection. Upon the filing of a petition by or against Tenant under the Code, Tenant, as Debtor and as Debtor-In-Possession, and any Trustee who may be appointed agree to adequately protect Landlord as follows: (i) to perform each and every obligation of Tenant under this Lease until such time as this Lease is either rejected or assumed by Order of the Bankruptcy Court; (ii) to pay all monetary obligations required under this Lease, including without limitation, payment of Rent and Additional Rent payable hereunder which is considered reasonable compensation for the use and occupancy of the Premises; (iii) provide Landlord a minimum of thirty (30) days prior written notice, unless a shorter period is agreed to in writing by the parties, of any proceeding relating to any assumption of this Lease or any intent to abandon the Premises, which abandonment shall be deemed a rejection of this Lease; and (iv) to perform to the benefit of Landlord as otherwise required under the Code. The failure of Tenant to comply with the above shall result in an automatic rejection of this Lease.

19. DEFAULT.

19.1. Cumulative Remedies. All rights of Landlord in this Lease shall be cumulative, and none shall exclude any other right or remedy allowed by law in force when the default occurs or in equity. In addition to the other remedies provided in this Lease, Landlord shall be entitled to restrain by injunction (without bond) the violation or attempted violation of any of the covenants, agreements or conditions of Tenant under this Lease.

19.2. Tenant's Default; Right to Cure. The failure of Tenant to perform any obligation of Tenant as provided in this Lease shall be a default under this Lease. Tenant shall have a period of five (5) business days from the date of Tenant's receipt of written notice from Landlord to Tenant within which to cure any default in the payment of Rent. Tenant shall have a period of ten (10) business days from the date of written notice from Landlord to Tenant to cure any other default under this Lease; provided, however, that with respect to any such default which cannot be cured within such ten (10) day period, the default shall not be deemed to be uncured if Tenant commences to cure within ten (10) days and for so long as Tenant is diligently prosecuting the cure thereof, but in no event longer than ninety (90) days. If the nature of the default is one that can be cured immediately (e.g. turn off loud music, take unauthorized sign off door, etc.), Tenant will use its best efforts to cure immediately. Notwithstanding anything herein to the contrary, if Tenant is in default under any covenant, condition, or agreement of this Lease more than one (1) time within any twelve (12) month period, irrespective of whether or not such default is cured, Landlord, at its sole election, in its sole and absolute discretion, and without notice to Tenant, may exercise any and all of its available rights and remedies.

19.3. Landlord's Rights And Remedies. Upon the occurrence of an uncured default by Tenant, Landlord, in addition to all other rights or remedies it may have, at its option, may exercise any one or more of the following rights without further notice or demand of any kind to Tenant or any other person, except as required by applicable State law:

19.3.1. Termination of Lease. The right of Landlord to terminate this Lease and Tenant's right to possess the Premises and to reenter the Premises, take possession thereof and remove all persons from the Premises, following which Tenant shall have no further claim thereon or hereunder; provided, however, that Tenant shall remain obligated as provided in Section 19.4 below.

19.3.2. Re-entry of the Premises. The right of Landlord, without terminating this Lease and Tenant's right to possess the Premises, to reenter the Premises and occupy the whole or any part of the Premises for and on account of Tenant and to collect any unpaid Rents which have become payable, or which may thereafter become payable; provided, however, that Tenant shall remain obligated as provided in Section 19.4 below.

19.3.3. Termination After Reentry. The right of Landlord, even though it may have reentered the Premises in accordance with Section 19.3.2, to elect thereafter to

terminate this Lease and Tenant's right to possess the Premises; provided, however, that Tenant shall remain obligated as provided in Section 19.4 below.

Should Landlord reenter the Premises under Section 19.3.2, Landlord shall not be deemed to have terminated this Lease or to have accepted a surrender thereof by any such reentry, unless Landlord shall have notified Tenant in writing that it has so elected to terminate this Lease and Tenant's right of possession. Tenant further covenants that Landlord's service of any notice pursuant to the unlawful detainer statutes of the State of Washington and Tenant's surrender of possession pursuant to such notice shall not (unless Landlord elects in writing to the contrary at the time of, or at any time subsequent to, the serving of such written notice and such election is evidenced by a notice to Tenant) be deemed to be a termination of this Lease.

19.4. Landlord's Damages. If Landlord terminates this Lease and/or Tenant's right to possession of the Premises pursuant to the terms of this Section 19, Landlord may recover from Tenant as damages, all of the following:

19.4.1. Delinquent Rent. The worth at the time of award of any unpaid Rent earned at the time of such termination;

19.4.2. Rent After Termination Until Judgment. The worth at the time of award of the amount by which the unpaid Rent that would have been earned after termination until the time of award exceeds such rent loss Tenant proves could have been reasonably avoided;

19.4.3. Rent After Judgment. The worth at the time of award of the amount by which the unpaid Rent for the balance of the Lease Term after the time of award exceeds the amount of such rent loss that Tenant proves could be reasonably avoided;

19.4.4. Leasing Concessions. The unamortized portion of any financial concessions incurred by Landlord on Tenant's behalf to arrange for Tenant's leasing of the Premises that Landlord conditionally waived at the commencement of the Lease in consideration of Tenant's full performance of this Lease, but which upon termination of the Lease pursuant to this Section 19 shall accrue as Rent, which costs include, but are not limited to, leasing commissions, tenant allowances and improvements (including without limitation, the cost of any improvements to the Premises by Landlord pursuant to Exhibit C), "free rent" allowances and other such concessions in this Lease, amortized on a straight-line basis over the number of months during the Lease Term in which Tenant is obligated to pay Base Rent, and such amounts shall become immediately due and payable as Rent earned at the time of such termination of the Lease;

19.4.5. Other Compensation. Any other amount necessary to compensate Landlord for all the detriment proximately caused by Tenant's failure to perform its obligations under this Lease or which in the ordinary course of things would be likely to result therefrom, including, without limitation, any cost or expense incurred by Landlord in (i) retaking possession of the Premises, including reasonable attorney fees therefore, (ii) maintaining or preserving the Premises after such default, (iii) preparing the Premises for reletting to a new tenant, including repairs necessary to the Premises for such reletting, (iv) leasing commissions, limited to those years remaining in the initial term, and (v) any other costs necessary or appropriate to relet the Premises; and

19.4.6. Additional or Alternative Damages. At Landlord's election, such other amounts in addition to or in lieu of the foregoing in this Section 19.4 as may be permitted from time to time by the laws of the State of Washington; and

19.4.7. Calculation of Damages. As used in Sections 19.4.1 and 19.4.2, the "worth at the time of award" is to be computed by allowing interest at the rate specified in Section 4.2. As used in Section 19.4.3, the "worth at the time of award" is computed by discounting such amount at a discount rate equal to six percent (6%) per annum. All Rent, other than Base Rent, shall, for the purposes of calculating any amount due under the provisions of Section 19.4.3 be computed on the basis of the average monthly amount thereof accruing during the immediately preceding sixty (60) month period, except that if it becomes necessary to compute

such rent before such a sixty (60) month period has occurred, then such rent shall be computed on the basis of the average monthly amount hereof accruing during such shorter period.

19.5. Tenant's Property. Without limiting any of Landlord's rights under this Lease, in the event of a termination of this Lease pursuant to Section 19, any of Tenant's property which, pursuant to this Lease, may be removed by the Tenant (not including attached furniture and equipment specified on Exhibit C-1) shall be removed by Tenant immediately upon demand by Landlord. If not so removed by Tenant, Landlord may remove such property from the Premises and place it in storage at a public warehouse at the expense and risk of Tenant, after which it shall be subject to the sale provisions of Section 21. Without limiting any of Landlord's rights under this Lease, in the event of a termination of this Lease pursuant to Section 19, all attached furniture and equipment specified on Exhibit C-1 shall, at Landlord's election, be deemed real property and shall be Landlord's property as part of the Premises upon termination.

19.6. No Waiver. The waiver by Landlord of any breach of any term, covenant or condition contained in this Lease shall not be deemed to be a waiver of such term, covenant or condition or any subsequent breach thereof, or of any other term, covenant or condition contained in this Lease. Landlord's subsequent acceptance of partial rent or performance by Tenant shall not be deemed to be an accord and satisfaction or a waiver of any preceding breach by Tenant of any term, covenant or condition of this Lease or of any right of Landlord to a forfeiture of the Lease by reason of such breach, regardless of Landlord's knowledge of such preceding breach at the time of Landlord's acceptance. No term, covenant or condition of this Lease shall be deemed to have been waived by Landlord unless such waiver is in writing and signed by Landlord.

19.7. Waiver of Notice. Notwithstanding anything to the contrary in this Section 19, Tenant waives (to the fullest extent permitted under law) any written notice, other than such notice as this Section 19 or any other provision of this Lease specifically requires, which any statute or law now or hereafter in force prescribes be given Tenant.

19.8. Waiver of Redemption Rights. Tenant, for itself, and on behalf of any and all persons claiming through or under it, including creditors of all kinds, does hereby waive and surrender all right and privilege which they or any of them might have under or by reason of any present or future law, to redeem the Premises or to have a continuance of this Lease for the term hereof, as it may have been extended, after having been dispossessed or ejected there from by process of law or under the terms of this Lease or after the termination of this Lease as herein provided.

19.9. Default by Landlord. Landlord's failure to perform or observe any of its obligations under this Lease or to correct a breach of any warranty or representation made in this Lease, including maintaining levels of performance for operation of Tenant's data center related to Landlord's Work as provided in the Approved Plans attached as Attachment 1 to Exhibit C (Work Letter Agreement), within thirty (30) days after receipt of written notice from Tenant setting forth in reasonable detail the nature and extent of the failure referencing pertinent Lease provisions or if more than thirty (30) days is required to cure the breach, Landlord's failure to begin curing within the thirty (30) day period and diligently prosecute the cure to completion, shall constitute a default. If Landlord commits a default that materially affects Tenant's use of the Premises, and Tenant has provided simultaneous written notice thereof to Landlord's mortgagee (if any and if Tenant has notice thereof) and Landlord (and/or Landlord's mortgagee if any) has failed to commence to cure such default within thirty (30) days (or such shorter time as is commercially reasonable in the case of an emergency threatening imminent harm to persons or property), Tenant may, without waiving any claim for damages or other relief for breach of agreement, thereafter cure the default for the account of the Landlord, which cure shall be preceded by an additional written notice given at least three (3) days prior to such cure to Landlord and Landlord's mortgagee that Tenant plans to undertake the cure, and the reasonable cost of such cure shall be deemed paid or incurred for the account of Landlord, and Landlord shall reimburse Tenant for Tenant's out-of-pocket expenditures paid to third parties to effectuate such cure, such reimbursement to be within thirty (30) days after completion of the cure and invoice to Landlord showing the costs of cure. If Landlord disputes either the necessity of the cure or the cost thereof, the matter shall be settled by arbitration administered by the American Arbitration Association in accordance with its Rules for the Real Estate Industry before a single neutral arbitrator of the American Arbitration Association sitting in Seattle, Washington. The arbitrator shall be a person having at least ten (10) years' experience and

knowledge about commercial leasing and property management. The arbitration shall be held within sixty (60) days of Landlord notifying Tenant it disputes Tenant's cure. The costs of the arbitrator shall be shared equally by the parties. The prevailing party shall be entitled to an award of reasonable attorney's fees. The arbitrator's award shall be final and binding on the parties.

20. SUBORDINATION AND ATTORNMENT. This Lease shall be subordinate to any mortgage or deed of trust now existing or hereafter placed upon the Land, the Building or the Premises, created by or at the instance of Landlord, and to any and all advances to be made hereunder and to interest thereon and all modifications, renewals and replacements or extensions thereof ("Landlord's Mortgage"); provided, however, that the holder of any Landlord's Mortgage or any person or persons purchasing or otherwise acquiring the Land, Building or Premises at any sale or other proceeding under any Landlord's Mortgage may elect to continue this Lease in full force and effect and, in such event, Tenant shall attorn to such person or persons. Notwithstanding the foregoing, if a lender requires that the Lease be subordinate to any mortgage recorded after the date of the Lease affecting the Property, the Lease shall be subordinate to such mortgage if Landlord first obtains from such lender a written statement providing that so long as Tenant performs its obligations under the Lease, no foreclosure of, deed given in lieu of foreclosure of, or sale under the mortgage, and no steps or procedures, taken under the mortgage, shall affect Tenant's rights under this Lease; provided, however, then the holder of Landlord's Mortgage, or any person or persons purchasing or otherwise acquiring the Land, Building or Premises at any sale or other proceeding under any Landlord's Mortgage, shall not be subject to any option to purchase, or right of first refusal to purchase, granted to Tenant in connection with this Lease.

Tenant shall execute, acknowledge and deliver documents, which the Holder of any Landlord's Mortgage may require to effectuate the provisions of this Section 20 within ten (10) days of the date of Landlord's request therefore. In the event of any transfer of Landlord's interest in the Premises or in the Property, other than a transfer for security purposes only, the transferor shall be automatically relieved of any and all obligations and liabilities on the part of Landlord accruing from and after the date of such transfer and such transferee shall have no obligation or liability with respect to any matter occurring or arising prior to the date of such transfer. Tenant agrees to attorn to such transferee, provided transferee assumes all of Landlord's responsibilities. If any holder of any Landlord's Mortgage shall request reasonable modifications to this Lease, Tenant shall not unreasonably withhold, delay or defer its consent thereto, provided such modifications do not have a materially adverse affect on Tenant's rights hereunder.

21. REMOVAL OF PROPERTY. Subject to Section 19.5, upon the expiration of this Lease, Tenant shall remove Tenant's personal property not permanently affixed to the Premises or as specified on Exhibit C-1, and shall pay Landlord any damages for injury to the Premises or Property resulting from such removal. If Tenant fails to remove any such property from the Premises at the expiration of this Lease, Landlord may remove and store said property without liability for loss thereof or damage thereto. Such storage shall be for the account and at the expense of Tenant. If Tenant fails to pay the cost of storing any such property after it has been stored for a period of thirty (30) days or more, or if Tenant has not removed the property from the Premises after a thirty (30) day period, Landlord may, at its option, sell, or permit to be sold, any or all such property at public or private sale, in such manner and at such times and places as Landlord in its sole discretion may deem proper, without notice to Tenant, unless notice is required under applicable statutes, and shall apply the proceeds of such sale first, to the cost and expense of such sale, including reasonable attorneys' fees actually incurred; second, to the payment of the costs or charges for storing any such property; third, to the cost of removal of such property and the restoration of the Premises following such removal; fourth, to the payment of any other sums of money which may then be or thereafter become due Landlord from Tenant under any of the terms of this Lease; and, fifth, the balance, if any, shall be paid to Tenant. Notwithstanding the foregoing, with respect to any conduit or cable installed in the Building by or on behalf of Tenant, Landlord shall have the right, at its option, in its sole discretion, on the Expiration Date, to take possession of such conduit and cable and, upon exercise of such right, Landlord shall be the owner thereof notwithstanding anything to the contrary contained in this Lease. Tenant agrees to execute and deliver any necessary documentation to effectuate the transfer of ownership of the conduit and cable to Landlord.

22. CONDEMNATION.

22.1. Entire Taking. If all of the Premises, or such portion of the Building as may be required for the reasonable use of the Premises, in Landlord's determination, are taken by eminent domain, this Lease shall automatically terminate as of the date title vests in the condemning authority and all Rent, Additional Rent and other payments shall be paid to that date. Should termination occur prior to the twelfth (12th) year of this Lease, Landlord shall refund to Tenant a pro rata share of the Additional Rent paid for Tenant Improvements based on a twelve (12) year amortization of the Tenant Contribution paid for Tenant Improvements.

22.2. Constructive Taking of Entire Premises. In the event of a taking by eminent domain of a material part of but less than all of the Building, if Landlord determines that the remaining portions of the Building cannot be economically and effectively used by it (whether on account of physical, economic, aesthetic or other reasons) or if Landlord determines the Building should be restored in such a way as to materially alter the Premises, then Landlord shall forward a written notice to Tenant of such determination not more than sixty (60) days after the date of taking. The Term of this Lease shall expire upon the date specified by Landlord in such notice but not earlier than sixty (60) days after the date of such notice. Should Landlord provide Tenant with written notice of termination pursuant to this Section 22.2 prior to the twelfth (12th) year of this Lease, Landlord shall refund to Tenant a pro rata share of the Tenant's Contribution paid for Tenant Improvements based on a twelve (12) year amortization of the Additional rent paid for Tenant Improvements.

22.3. Partial Taking. Subject to the provisions of the preceding Section 22.2, in case of taking by eminent domain of a part of the Premises, or a portion of the Building not required for the reasonable use of the Premises, then this Lease shall continue in full force and effect and the Rent shall be equitably reduced based on the proportion by which the floor area of the Premises is reduced, such Rent reduction to be effective as of the date title to such portion vests in the condemning authority. If more than twenty-five percent (25%) of the Premises is taken and Landlord cannot replace such space with space in the Building, which is mutually acceptable to Landlord and Tenant, then with sixty (60) days written notice by either party, Landlord or Tenant shall have the right to terminate this Lease.

22.4. Awards and Damages. Landlord reserves all rights to damages to the Premises for any partial, constructive, or entire taking by eminent domain, and Tenant hereby assigns to Landlord any right Tenant may have to such damages or award, and Tenant shall make no claim against Landlord or the condemning authority for damages for termination of the leasehold interest or interference with Tenant's business. Tenant shall have the right, however, to claim and recover from the condemning authority compensation for any loss to which Tenant may be put for Tenant's moving expenses, business interruption or taking of Tenant's personal property (not including Tenant's leasehold interest) provided that such damages may be claimed only if they are awarded separately in the eminent domain proceedings and not out of or as part of and/or will not reduce any damages recoverable by Landlord.

23. NOTICES. All notices under this Lease shall be in writing and delivered in person or sent by registered or certified mail, postage prepaid, or by facsimile, or by private overnight courier to Landlord, Landlord's Mortgagee (if any) and Tenant at their respective Notice Addresses set forth in Section 1.17 (provided that after the Commencement Date any such notice shall be mailed, delivered by hand or transmitted by facsimile to Tenant at the Premises) or such other addresses as may from time to time be designated by amending applicable provisions of this Lease in writing. Notices mailed as provided in this Section shall be deemed given and received on the date that is three (3) business days following the date of post mark, in the case of mailing, or the date of transmission confirmation by the sender's facsimile machine, in the case of facsimile transmission, or one (1) day after deposit with a private overnight courier.

24. COSTS AND ATTORNEYS' FEES. If Tenant or Landlord brings any action for any relief against the other, declaratory or otherwise, including arbitration as provided in Section 8.4, arising out of this Lease, each party shall, and hereby does to the extent permitted by law, waive trial by jury and the losing party shall pay the substantially prevailing party's attorneys' fees in connection with such suit, at trial and on appeal, and such attorneys' fees shall be deemed to have accrued on the commencement of such action.

25. LANDLORD'S LIABILITY. Notwithstanding anything in this Lease to the contrary, covenants, undertakings and agreements herein made on the part of Landlord in this Lease are made and intended not as personal covenants, undertakings and agreements for the purpose of binding Landlord personally or the assets of Landlord (except Landlord's interest in the Premises and Building), but are made and intended for the purpose of binding only the Landlord's interest in the Premises and Building, as the same may from time to time be encumbered. Notwithstanding anything to the contrary herein, Landlord's maximum aggregate liability to Tenant shall be limited to the total amount of Rent and Additional Rent for Tenant Improvement work paid to Landlord hereunder during the initial term hereof. No personal liability or personal responsibility is assumed by Landlord, nor shall at any time be asserted or enforceable against Landlord or its heirs, legal representatives, successors or assigns on account of the Lease or on account of any covenant, undertaking or agreement of Landlord in this Lease. In no event shall Landlord be liable for lost profits, business interruption (except as to services provided in Exhibit C-2 and then limited to the actual cost of establishing alternative datacenter space, but limited to the amount of Base Rent and Additional Rent calculated on a monthly basis), incidental, special or punitive damages. In no event shall any incidental, consequential, special, exemplary, speculative, or punitive damages, including without limitation any claims for lost or imputed revenues, profits, and/or business opportunities be part of any Landlord liability.

26. LANDLORD'S CONSENT. Except as may be provided otherwise in this Lease, whenever Landlord's consent is required under this Lease, such consent shall not be unreasonably withheld, conditioned or delayed, provided, however, Landlord's withholding of consent due to any mortgagee's refusal to grant its consent shall not be deemed unreasonable.

27. ESTOPPEL CERTIFICATES. Tenant shall, from time to time upon the written request of Landlord, execute, acknowledge and deliver to Landlord or its designee a written statement stating: the Effective Date, Commencement Date and Expiration Date, the date the term commenced and the date Tenant accepted the Premises; the amount of Base Rent and the date to which such Base Rent and Additional Rent has been paid; and certifying such additional information as may be requested by Landlord. It is intended that any such statement delivered pursuant to this Section may be relied upon by Landlord and/or a prospective purchaser or mortgagee who may acquire an interest in, or a lien upon, Landlord's interest in the Building. If Tenant shall fail to respond within ten (10) days of receipt by Tenant of a written request by Landlord as herein provided, Tenant shall be deemed to have given such certificate as above provided without modification and shall be deemed to have admitted the accuracy of any information supplied by Landlord to a prospective purchaser or mortgagee and to have certified that this Lease is in full force and effect, that this Lease represents the entire agreement between the parties as to this leasing, that there are no existing claims, defenses or offsets which Tenant has against enforcement of the Lease by Landlord, that there are no uncured defaults in Landlord's performance, that the security deposit is as stated in the Lease, and that not more than one month's Base Rent or Additional Rent has been paid in advance.

28. RIGHT TO PERFORM. If Tenant fails to pay any sum of money required to be paid by it under this Lease or fails to perform any other act on its part to be performed under this Lease, and such failure continues for ten (10) days after notice thereof by Landlord, Landlord may, but shall not be obligated to do so, and without waiving or releasing Tenant from any obligations of Tenant, make such payment or perform any such other act on Tenant's part to be made or performed as provided in this Lease. Landlord shall have (in addition to any other right or remedy of Landlord) the same rights and remedies in the event of the nonpayment of sums due under this Section 28 as in the case of default by Tenant in the payment of Rent.

29. PARKING. All parking that serves SDC is on a non-reserved, first-come first-served basis and Tenant shall have full access to said parking. Tenant's use of the parking stalls shall be subject to such market rate charges as are customary for similar commercial space in the City of Tukwila, and such rules and regulations, as Landlord and/or Landlord's parking operator may adopt from time to time. Landlord retains the right to alter such market rate charges, and such rules and regulations and to relocate within the area as outlined on Exhibit E, or reconfigure the parking area shown on Exhibit E, with reasonable notice to Tenant. Tenant shall pay, upon demand by Landlord, Landlord's costs incurred to stencil any changes to reserved parking stalls provided to Tenant under this Lease.

30. AUTHORITY. If Tenant is a corporation, each individual executing this Lease on behalf of Tenant represents and warrants that he or she is duly authorized to execute and deliver this Lease on behalf of Tenant, in accordance with a duly adopted resolution of the Board of Directors of Tenant and in accordance with the bylaws of Tenant, and that this Lease is binding upon Tenant in accordance with its terms. If Tenant is a partnership or limited liability company, each individual executing this Lease on behalf of Tenant represents and warrants that he or she is duly authorized to execute and deliver this Lease on behalf of Tenant, in accordance with the partnership or operating agreement of Tenant, and that this Lease is binding upon Tenant in accordance with its terms.

31. GENERAL.

31.1. Headings. Titles to Sections of this Lease are not a part of this Lease and shall have no effect upon the construction or interpretation of this Lease.

31.2. Heirs and Assigns. All of the covenants, agreements, terms and conditions contained in this Lease shall inure to and be binding upon the Landlord and Tenant and their respective heirs, executors, administrators, successors and assigns.

31.3. No Brokers. Except as provided in Section 1.1, Landlord and Tenant represent and warrant to one another that they have not engaged any broker, finder or other person who would be entitled to any commission or fees in respect of the negotiation, execution or delivery of this Lease and Landlord and Tenant shall indemnify and hold one another harmless from and against any loss, cost, liability or expense incurred by the other party as a result of any claim asserted by any such broker, finder or other person on the basis of any arrangements or agreements made or alleged to have been made by or on behalf of the other party. In no event will a brokerage fee be paid on any renewal or Option to renew. Tenant agrees that any broker it may elect to assist in any renewal discussions or options will be compensated directly by Tenant.

31.4. Entire Agreement. This Lease contains all covenants and agreements between Landlord and Tenant relating in any manner to the leasing, use and occupancy of the Premises, to Tenant's use of the Building and other matters set forth in this Lease. No prior agreements or understanding pertaining to the same shall be valid or of any force or effect and the covenants and agreements of this Lease shall not be altered, modified or added to except in writing signed by Landlord and Tenant.

31.5. Severability. Any provision of this Lease which shall prove to be invalid, void or illegal shall in no way affect, impair or invalidate any other provision hereof and the remaining provisions hereof shall nevertheless remain in full force and effect.

31.6. Force Majeure. (A) Landlord. Landlord shall have no liability whatsoever to Tenant on account of Landlord's inability to perform any of its obligations under this Lease, in whole or part, including to timely complete Landlord's Work, or the restoration of the Building and the Premises following damage or destruction, as a result of "force majeure," which shall include (a) strike, lockout, other labor trouble, dispute or disturbance; (b) governmental regulation, moratorium, action, preemption or priorities or other controls; (c) shortages of fuel, supplies or labor, other than those which were reasonably foreseeable; (d) any failure or defect in the supply, quantity or character of electricity or water furnished to the Premises by reason of any requirement, act or omission of the public utility or others furnishing the Building with electricity or water; and (e) for any other reason, whether similar or dissimilar to the above, or for Act of God, beyond Landlord's reasonable control and which were not reasonably foreseeable. If this Lease specifies a time period for performance of an obligation of Landlord to complete Landlord's Work, or the restoration of the Building and the Premises following damage or destruction, that time period shall be extended by the period of any delay in Landlord's performance caused by any of the events of force majeure described herein.

(B) Tenant. Tenant shall have no liability whatsoever to Landlord on account of Tenant's inability to timely complete Tenant's Work, or the restoration of the Tenant's Work following damage or destruction, as a result of "force majeure," which shall include (a) strike lockout, other labor trouble, dispute or disturbance; (b) governmental regulation, moratorium, action, preemption or priorities or other controls; (c) shortages of fuel, supplies or labor; (d) any failure or defect in the supply, quantity or character of electricity or water furnished to the Premises by reason of any

requirement, act or omission of the public utility or others furnishing the Building with electricity or water; and (e) for any other reason, whether similar or dissimilar to the above, or for Act of God, beyond Tenant's reasonable control. If this Lease specifies a time period for performance of an obligation of Tenant to complete Tenant's Work, or the restoration of Tenant's Work following damage or destruction, that time period shall be extended by the period of any delay in Tenant's performance caused by any of the events of force majeure described herein. Nothing in this section shall be construed as excusing or delaying the obligation of Tenant to pay in a timely manner when due any Rent or other amounts due under this Lease.

31.7. Right to Change Public Spaces. Landlord shall have the right at any time without thereby creating an actual or constructive eviction or incurring any liability to Tenant therefore, to change the arrangement or location of such of the following as are not contained within the Premises or any part thereof: entrances, passageways, doors and doorways, corridors, stairs, toilets and other public portions of the Property. In no event, however, shall Landlord diminish any service provided by Landlord under this Lease, make any change which reduces the area of the Premises, make any change which, on other than a temporary basis, either changes the character of the Building or materially interferes with Tenant's access to and use of the Building.

31.8. Governing Law. This Lease shall be governed by and construed in accordance with the laws of the State of Washington.

31.9. Building Directory. In the event Landlord maintains in the lobby of the Building a directory of tenants, such directory shall include the name of Tenant and any other names reasonably requested by Tenant in proportion to the number of listings given to comparable tenants of the Building. Tenant will also be required to provide suite signage consistent with the Building standard or subject to Landlord's architects' approval.

31.10. Building Name. The Building will be known as Sabey DataCenter or by such name as Landlord may designate from time to time.

31.11. Quiet Enjoyment. Landlord agrees that Tenant, upon paying the Rent and performing all other terms, covenants and conditions of this Lease to be performed by Tenant, may quietly have, hold and enjoy the Premises from and after the Commencement Date until the Expiration Date, subject, however, to the provisions of Section 11 (Damage Or Destruction) and 22 (Condemnation).

31.12. Survival. The representations, warranties and indemnification obligations of the parties to this Lease shall survive the termination or expiration of this Lease.

31.13. Lender's Consent. The effectiveness of this Lease is contingent upon and subject to the approval of Landlord's lender, which approval shall be secured by Landlord prior to execution of this Lease.

31.14. Time. Time is of the essence of each and every provision of this Lease.

31.15. Interpretation. This Lease has been submitted to the scrutiny of all parties hereto and their counsel, if desired, and shall be given a fair and reasonable interpretation in accordance with the words hereof, without consideration or weight being given to its having been drafted by any party hereto or its counsel.

31.16. Execution. This Lease may be executed in several counterparts and all so executed shall constitute one Lease, binding on all the parties hereto even though all the parties are not signatories to the original or the same counterpart. Delivery of a facsimile or other copy of this Lease has the same effect as delivery of an original.

32. PRIME LEASE; SUBLEASE PROVISIONS.

32.1. Prime Lease. Landlord leases the Building pursuant to a Lease ("Prime Lease") entered into with INTERNATIONAL GATEWAY EAST LLC ("Owner"), which

is the owner of the Building. This Lease is a sublease under the Prime Lease, subject to the terms of this Section 32.

32.2. Landlord Representations. Landlord represents to Tenant that: (a) the Prime Lease is, as of the date hereof, in full force and effect; (b) no event of default has occurred under the Prime Lease and, to Landlord's knowledge, no event has occurred and is continuing which would constitute an event of default but for the requirement of the giving of notice and/or the expiration of the period of time to cure; (c) the initial term of the Prime Lease runs beyond the Expiration Date, as such date may be extended under this Lease.

32.3. Owner Agreements.

By its signature below, Owner hereby agrees as follows:

- A. Owner hereby consents to this Lease as a sublease of the Premises.
- B. With respect to the Premises, the provisions of this Lease shall override and supersede all terms and provisions of the Prime Lease, so that so long as Tenant is not in default under this Lease (subject to any cure rights provided in this Lease), the Prime Lease with respect to the Premises shall be deemed satisfied and this Lease shall remain in full force and effect.
- C. In the event the Prime Lease is terminated for any reason, Owner agrees that it will recognize this Lease as in full force and effect as a direct lease between Owner as landlord and Tenant as tenant, with Owner recognizing all Tenant's rights under this Lease so long as Tenant is not in default under this Lease (subject to any cure rights provided in this Lease). Owner shall assume all of Landlord's obligations hereunder and Tenant shall be given full credit for all amounts paid to Landlord hereunder. If necessary, Owner shall enter into a new lease on all of the terms and conditions contained in this Lease. All of the foregoing shall be completed without any interruption of Tenant's use or possession of the Premises.
- D. Owner represents to Tenant that: (a) the Prime Lease is, as of the date hereof, in full force and effect; (b) no event of default has occurred under the Prime Lease and, to Owner's knowledge, no event has occurred and is continuing which would constitute an event of default but for the requirement of the giving of notice and/or the expiration of the period of time to cure; (c) the initial term of the Prime Lease runs beyond the Expiration Date, as such date may be extended under this Lease.

IN WITNESS WHEREOF this Lease has been executed the day and year first above set forth.

LANDLORD:

SABEY DATACENTER LLC,
by Sabey Corporation, Manager

Date: _____

By: _____
Its: _____

TENANT:

KING COUNTY

Date: _____

By: _____
Its: _____

APPROVED AS TO FORM ONLY:

Date: _____

By: _____
Timothy Barnes
Senior Deputy Prosecuting Attorney

Date: _____

By: _____
Kathy Brown
Director, Facilities Management Division

OWNER:

INTERNATIONAL GATEWAY EAST LLC,
by Sabey Corporation, Manager

Date: _____

By: _____
Its: _____

STATE OF WASHINGTON)
) ss.
COUNTY OF KING)

On this _____ day of _____, 2008, before me, the undersigned, a Notary Public in and for the State of Washington, duly commissioned and sworn as such, personally appeared Patricia A. Sewell, to me known to be the Secretary of SABEY CORPORATION, Manager of SABEY DATACENTER LLC, the corporation that executed the within and foregoing instrument, and acknowledged the said instrument to be the free and voluntary act and deed of said corporation for the uses and purposes therein mentioned, and on oath stated that he was authorized to execute said instrument.

WITNESS my hand and official seal the day and year in this certificate first above written.

Printed Name: _____
NOTARY PUBLIC in and for the State of Washington,
residing at _____
My commission expires: _____

STATE OF WASHINGTON)
) ss.
COUNTY OF KING)

On this _____ day of _____, 2008, before me, the undersigned, a Notary Public in and for the State of Washington, duly commissioned and sworn as such, personally appeared _____, to me known to be the _____ of KING COUNTY, a political subdivision of the State of Washington that executed the within and foregoing instrument, and acknowledged the said instrument to be the free and voluntary act and deed of said agency for the uses and purposes therein mentioned, and on oath stated that he/she was authorized to execute said instrument.

WITNESS my hand and official seal the day and year in this certificate first above written.

Printed Name: _____
NOTARY PUBLIC in and for the State of _____,
residing at _____
My commission expires: _____

STATE OF WASHINGTON)
) ss.
COUNTY OF KING)

On this _____ day of _____, 2008 before me, the undersigned, a Notary Public in and for the State of Washington, duly commissioned and sworn as such, personally appeared Patricia A. Sewell, to me known to be the Secretary of SABEY CORPORATION, Manager of INTERNATIONAL GATEWAY EAST LLC, the company that executed the within and foregoing instrument, and acknowledged the said instrument to be the free and voluntary act and deed of said company for the uses and purposes therein mentioned, and on oath stated that he was authorized to execute said instrument.

WITNESS my hand and official seal the day and year in this certificate first above written.

Printed Name: _____
NOTARY PUBLIC in and for the State of Washington,
residing at _____
My commission expires: _____

EXHIBIT A
TO LEASE AGREEMENT
LEGAL DESCRIPTION

LOT 5 OF BOUNDARY LINE ADJUSTMENT NO. L02-087 RECORDED UNDER KING COUNTY RECORDING NO. 20030327900002, RECORDS OF KING COUNTY, AS AMENDED BY RECORDING NUMBER 200307250001852, RECORDS OF KING COUNTY; SITUATE IN THE CITY OF TUKWILA, COUNTY OF KING, STATE OF WASHINGTON

EXHIBIT B
TO LEASE AGREEMENT
FLOOR PLAN OF PREMISES

EXHIBIT C

TO LEASE AGREEMENT

WORK LETTER AGREEMENT

IMPROVEMENTS MADE BY LANDLORD (LANDLORD'S WORK)

This Work Letter Agreement is part of and incorporated into that certain lease (the "Lease") between King County, a political subdivision of the State of Washington (hereinafter called "Tenant") and Sabey Datacenter, LLC (hereinafter called "Landlord") for the Premises, as defined in section 1.4 of the Lease, located at 3355 South 120th Place, Suite 5201 (SDC52), Seattle, WA 98168.

1. **General Intent.** It is the intent of this Work Letter Agreement that Landlord shall construct "Landlord's Work" in accordance with the **Construction Documents** (described below) so long as the same is done at the sole cost and risk of Landlord and within the **Not-To-Exceed Cost** (described below). The Construction Documents shall contain the detailed design work necessary to meet the design and performance standards contained in the "Approved Plans," which are attached to the Lease as **Exhibit C-3**. Landlord's Work shall include all tenant improvements to the Premises (the "Tenant Improvements"). As more fully set out in the Construction Documents, the Tenant Improvements include:

1.1 Construction of an N+1 type data center to support a server load of 150 watts per square foot, server floor only including but not limited to: partitions, doors, ceilings, floors, floor finishes, walls, wall finishes, electrical (panels, wiring, cabling, lighting, switching, outlets, etc.), communications (wiring, cables, conduit and fiber), plumbing, heating, ventilation and air conditioning systems and equipment as specified by Tenant, conduits, pathways, maintenance access, innerduct/conduit from utility vault to Premises and from Premises to Building 2, and includes third party commissioning of all connections to Building systems and infrastructure;

1.2 Office Space .as specified by Tenant

1.3 "Cable Distribution Facilities," which means the areas within the Building comprised of the info-riser shaft(s), the conduits or other means of exiting the info-riser or infrastructure, and the cable trays, raceways or conduits providing the horizontal distribution pathway from the info-riser to a destination elsewhere in the Building; and

1.4 "Additional Services," which shall include any services requested by Tenant to be provided by Landlord not included in the Tenant Improvements and to be paid for separately if Landlord agrees to provide in writing.

2. **Intentionally Omitted.**

3. **Construction Documents.**

3.1 Landlord will obtain architectural, mechanical, and electrical plans required for the performance of the Tenant Improvement work addressed in this Work Letter Agreement, including plans and specifications for the Tenant Improvements (the "Construction Documents") which are prepared by Landlord's architect in accordance with Tenant's Approved Plans and which present a full and complete accounting of the scope of the Tenant Improvements, as well as required operating and performance standards. Landlord hereby approves and designates Callison Architects as architect ("Architect") for the Construction Documents. The Construction Documents shall be prepared pursuant to (i) Tenant's Approved Plans, attached hereto as Exhibit C-3; (ii) Landlord's Building Standard Specifications (the "Standards"), and (iii) all appropriate regulatory requirements. The Construction Documents shall include full construction drawings and specifications for the Tenant Improvements. Landlord shall contract directly with Architect for preparation of the Construction Documents. Landlord shall provide the Construction Documents to Tenant at

80% and 100% plan development stages for its review and written approval. Tenant approvals, comments or requests for revisions must be identified by Tenant and returned to Landlord within ten (10) business days after Tenant's receipt of the Construction Documents. Any further revisions by Landlord shall similarly be responded to by Tenant within ten (10) business days after Tenant's receipt of the Construction Documents. The final plans so approved by Landlord and Tenant at the 100% complete stage shall be the Construction Documents for all purposes hereunder, subject only to approved Field Change Orders in accordance with 4.2 below. Landlord shall also obtain the appropriate building permits, and shall construct the Tenant Improvements in accordance with the Construction Documents. Landlord shall perform all work necessary to substantially complete the Tenant Improvements within 270 days of Execution of the Lease. Landlord and Tenant agree to cooperate with each other in the completion of the Tenant Improvements by responding to each party's requests for information and approvals in a timely fashion.

3.2 Landlord and Tenant agree that the Construction Documents, once reviewed by Tenant and Landlord and signed by Tenant, and any Field Change Orders approved in accordance with Section 4.2 below, shall represent the complete understanding between Landlord and Tenant as to the scope of the Tenant Improvements to be constructed under the Lease and this Work Letter Agreement.

4. Cost of Tenant Improvement Work:

4.1 **Cost of Work.** Landlord and Tenant agree that Landlord has committed to constructing the Tenant Improvements at its sole cost and risk for a total not-to exceed price of \$9,500,000.00 (Nine Million Five Hundred Thousand Dollars) (the "Not-To-Exceed Cost" or "NTEC"). The NTEC shall include all costs of design, administration and construction costs in approving, furnishing and constructing the Landlord's Work pertaining to the Datacenter Space and Office Space in accordance with the Construction Documents, including without limitation the following: the cost of constructing improvements; any and all costs of space planning and design; the cost of preparing engineering plans; governmental agency plan check, permit and other fees; any costs arising from modifications required by governmental agencies to meet building or environmental codes; insurance premium; bond premium, sales and use taxes; signage; Landlord's administrative fee of five percent (5%) on all costs, including general conditions; applicable state and local taxes; and all other costs to be expended by Landlord in the construction of the Tenant Improvements.

4.2 **Revisions.** Revisions to the final approved Construction Documents, if any, are to be accomplished by Field Change Orders. A "Field Change Order" is a document which details the scope of a requested change to any work set forth in the Construction Documents and bears the signature of Tenant and Landlord representatives approving such change in scope. All such plans, specifications, and Field Change Orders shall be approved by Landlord and Tenant prior to being executed or acted upon by the Contractor. In order to avoid delays in construction, in the event the cost of the work included in a Field Change Order request is Twenty-five Thousand Dollars (\$25,000) or less, and the aggregate amount of Field Change Order requests has not exceeded One Hundred Thousand Dollars (\$100,000) Tenant will provide the necessary approval in writing without requiring the documentation set forth above, with written confirmation and cost itemization to follow. In the event the Field Change Order (other than a change order initiated by Landlord or necessitated by irregularities between design and construction functions [A&E coordination], or a result of unforeseen building conditions) increases the construction cost, Tenant shall be solely responsible for such increased cost and shall pay the same to Landlord in accordance with Section 7 of this Work Letter Agreement. In the event the Field Change Order is initiated by Landlord, including but not limited to those necessitated by irregularities between design and construction functions [A&E coordination], or as a result of unforeseen construction conditions, the cost shall be solely borne by Landlord and shall not be the responsibility of Tenant. The cost of Field Change Orders necessitated by Force Majeure shall be paid by Landlord at Landlord's sole expense, unless Tenant elects a different but equally viable option, in which case the cost shall be born by Tenant.

4.3 Tenant agrees that it shall designate a field representative who shall be available on not more than four (4) hours notice during the hours of construction to be present at the job site to respond to questions and Field Change Order issues. Tenant agrees to approve or disapprove any Field Change Order within ten (10) business days of receipt of notice of same. Approved Field Change Orders initiated by Tenant shall, if necessary, be accompanied by written amendments to the Lease adjusting the date for Substantial Completion and associated provisions accordingly.

5. Construction of Tenant Improvements

5.1 **General.** Landlord acknowledges that it is solely responsible for the Tenant Improvements contained in this Work Letter and that it will enter into a construction contract with a contractor of its choosing.

5.2 **Substantial Completion.** As used herein, "Substantially Completed" or "Substantial Completion" shall mean that on or before the 270th day following execution (execution is herein defined as the date on which both Landlord and Tenant have signed and notarized the Lease) each of the following have occurred subject only to completion of customary "punch list" items: (a) Landlord's contractor shall have notified Landlord in writing that Landlord's Work is substantially complete in accordance with the Construction Documents; (b) the City of Tukwila has issued a certificate of occupancy or temporary certificate of occupancy such that Tenant is legally entitled to occupy the Premises for its permitted use; and (c) the director of the King County Facilities Management Division shall have issued a written statement to Landlord stating Landlord's Work is sufficiently complete in accordance with the Construction Documents to permit Tenant to utilize the Premises for the Permitted Uses as defined in Sections 1.4 and 1.18, respectively, of the Lease. Tenant shall not unreasonably withhold, delay or condition its concurrence if each of the items (a) and (b) have occurred, and provided further, it shall be deemed unreasonable hereunder for Tenant to withhold its concurrence. Landlord agrees to provide Tenant no less than ten (10) business days advance notice of the substantial completion date, and for the sole purpose of determining substantial completion hereunder. Landlord shall include Tenant's representatives in all third party commissioning and provide reports as timely as possible.

5.3 **Indemnification.** Landlord shall indemnify, defend (using legal counsel acceptable to Tenant) and hold Tenant harmless from all claims, damages, costs, judgments and settlements against Tenant from Landlord's contractor or subcontractors arising from the construction covered in this Work Letter. Landlord further agrees to indemnify, defend and hold Tenant harmless for any personal injury or property damage claims arising from the construction of the Tenant Improvements contemplated in this Work Letter. Nothing in this Section 5.3 shall require Landlord to protect, defend and indemnify Tenant to the extent of its sole negligence. This indemnity with respect to acts or omissions during the term of construction of tenant improvements shall survive termination and expiration of the Lease. The foregoing indemnity covers actions brought by Landlord's own employees and it is specifically and expressly intended to constitute a waiver of Landlord's own immunity, as respects the Tenant only, under Washington's Industrial Insurance Act, RCW Title 51, only to the extent necessary to provide Tenant with a full and complete indemnity from claims made by Landlord and its employees, to the extent provided herein. Landlord shall promptly notify Tenant of casualties or accidents occurring during construction. **TENANT AND LANDLORD ACKNOWLEDGE THAT THE INDEMNIFICATION PROVISIONS OF THIS SECTION 5 WERE SPECIFICALLY NEGOTIATED AND AGREED UPON BY THEM.**

5.4 **Warranties.** Upon Substantial Completion of all Tenant Improvements, Landlord shall warrant that the Tenant Improvements have been completed in substantial accordance with the Construction Documents, and that the Tenant Improvements are free from defects

in workmanship and materials for one (1) year following the date of Substantial Completion.

5.5 Prevailing Wages. Landlord agrees that all contractors and subcontractors shall pay Prevailing Wages in accordance with chapter 39.12 RCW.

6. **Additional Services.** All Additional Services shall be contracted for and managed by Landlord at the direction of, and with the approval of Tenant. Tenant shall pay to Landlord all costs and expenses arising out of or related to Additional Services within 30 days, such Additional Services shall include, but are not limited to, acquisition of the furnishings for the Office Space.

7. **Payment for Tenant Improvements and Additional Services.**

7.1 Subject to the Landlord's indemnity set forth in Section 5.3 of this Work Letter Agreement, Tenant shall pay to Landlord the actual cost, but not in excess of the NTEC, plus any Additional Services, rendered as of the time of Tenant's Occupancy, plus any costs associated with Tenant's Field Change Orders, as a lump sum Tenant Contribution for Tenant Improvements in accordance with the terms of the Lease, Section 1.12.1.

7.2 Landlord shall keep accurate records of the Cost of Tenant Improvement as they are incurred during construction. Tenant shall have a right of reasonable access to such records and to all Tenant Improvement construction-related records on an open book basis. Tenant and Landlord shall cooperate in good faith to provide this access while minimizing interference with Landlord's operations. Upon Substantial Completion, Landlord shall provide Tenant with a final accounting of the actual costs of all Tenant Improvements as a precondition to payment. Monthly during construction, Landlord shall furnish Tenant with a summary report of such costs incurred since the date of the last report.

7.3 Landlord shall notify Tenant in writing as soon as is commercially reasonable as to any developments or information of any kind that could potentially lead to a delay in the construction schedule.

8. **GENERAL**

8.1 This Work Letter Agreement, the Approved Plans, and subsequent Construction Documents, and any approved Field Change Orders shall constitute the complete construction specifications and no other representations, or oral agreements between the parties shall be recognized in the event of a dispute between Landlord and Tenant.

8.2 Time is of the essence with respect to each of the duties and obligations of Landlord and Tenant set forth in this Work Letter Agreement. Notwithstanding any of the foregoing provisions hereof, default by Tenant or Landlord under any provisions of this Work Letter Agreement which are not cured within applicable notice and cure periods set forth in the Agreement shall constitute a default under the Agreement.

8.3 Any notice, statement, advice, approval, consent or other communication required or permitted to be given by either party to the other pursuant to this Work Letter Agreement shall be given in the manner set forth in Section 23 of the Lease. A default by Landlord of any obligation hereunder shall constitute a default by Landlord under the Lease.

TENANT AND SABEY DATACENTER LLC AGREE TO THE ABOVE TERMS CONTAINED
IN THIS EXHIBIT C AND ATTACHMENTS AND TO THE RELATED PROVISIONS OF THE
LEASE TO WHICH THIS EXHIBIT C IS ATTACHED.

TENANT:

KING COUNTY

By: _____

Date: _____

Its: _____

SABEY DATACENTER LLC, by
Sabey Corporation, Manager

By: _____

Date: _____

Its: _____

EXHIBIT C-1

TO LEASE AGREEMENT

TENANT'S REMOVABLE PROPERTY

Subject to the terms and conditions of this Lease, the fixtures, improvements, furniture, equipment and other property of Tenant which may be removed by Tenant from the Premises at the expiration or earlier termination of this Lease are as set forth below in this Exhibit C-1. No other improvements, alterations or property shall be removed from the Premises at the expiration or termination of this Lease except as may be provided otherwise in the Lease or as may be agreed upon by Landlord and Tenant and added to this Exhibit C-1 by amendment to this Lease.

1. Upon the termination or expiration of this Lease Tenant, at Tenant's expense, shall remove all cabling and wiring included within the scope of Tenant's Work, Landlord's Work, Tenant's Alterations, or which was otherwise installed by Tenant, from all interstitial/ceiling plenum areas upon Landlord's request.
2. Furniture and personal property.
3. Data System and Tenant's Computer Equipment.

EXHIBIT C-2

SERVICES OFFERING

I. SERVICES:

- (a) Maintenance, operation and repair of utility electric source and standby generators in accordance with manufacturer recommendations.
- (b) Maintenance, operation and repair of chillers and associated chilled water piping, valves, and components in accordance with manufacturer recommendations
- (c) 24-hour monitoring and on-call response to equipment alarms on generators and chillers.
- (d) Fire Suppression System
- (e) Generator backed-up electricity to server floor provided up to 1.2 megawatts.
- (f) Premises access 24 hours per day, subject to Section 10

Except in the event of an emergency, a court order or other exercise of legal authority, only Tenant's pre-authorized representatives shall be allowed to enter the Tenant's Premises without prior written authorization from Tenant.

II. MAINTENANCE:

Scheduled maintenance

Landlord will notify Tenant of all scheduled maintenance plans no less than seventy-two (72) hours prior to any scheduled maintenance on any critical environment equipment. Landlord must receive any objection Tenant has to the scheduled maintenance within twenty-four (24) hours of such notification. Tenant shall not unreasonably withhold, condition or delay its consent. Any objection by Tenant, to be effective, must include a reasonable maintenance alternative which must be mutually agreed upon by Landlord and Tenant.

In the event of an emergency maintenance situation, Landlord will provide Tenant with as reasonable notice as possible, and if needed, may perform emergency maintenance at any time. Tenant agrees to cooperate with Landlord during the scheduled and emergency maintenance periods.

III. CUSTOMER CONTACT IN THE EVENT OF AN INTERFERENCE OR NOTIFICATION:

Name: _____

Access Telephone Number: _____ (Pager)

_____ (Telephone)

_____ (e-mail)

EXHIBIT C-3
APPROVED PLANS

EXHIBIT C-3
APPROVED PLANS

EXHIBIT C-3
King County Enterprise Data Center
Essential Performance Requirements

Architectural

1. Provide a secured facility. All leased areas and their supporting infrastructure (including HVAC and power distribution systems) shall be continuously secured by access control and operational procedures, at a level similar to existing, reasonably designed to prevent intrusion to leased areas of unauthorized persons and activities. King County shall provide surveillance of the interiors of leased areas. King County is responsible for the actions of its employees, vendors, and other authorized visitors with respect to access control.
2. Provide as a minimum, one-hour-rated fire protection from adjacent tenants.

Mechanical

1. Provide HVAC system capability to maintain temperature and humidity in accordance with Attachment 'A' of this exhibit. Provide means of verification for design airflow, humidity, and temperatures are consistently delivered to leased areas. Maintain verifiable trend logs of all HVAC systems with a minimum of 90 days of data in 15 minute log intervals. Provide documentation of HVAC performance to King County on demand, with reasonable notice and intervals.
2. Temperatures and humidity requirements in 'critical areas' must be strictly maintained at a point 48" above the finished floor on a 24/7/365 basis with no interruptions. Downtime (defined as the loss of Normal and Backup systems) shall be limited to 1.6 hours annually with an uptime of 99.98%.
3. Provide verifiable means that mechanical systems, inclusive but not limited to air handling and chilled water generation and distribution systems, are designed, maintained and operated on an N+1 capability; except in the event of scheduled maintenance and unplanned events not reasonably foreseeable by the landlord. Maintain detailed design data and calculations that define design requirements of all tenants whose systems are connected to systems serving King County spaces. Provide design data, details, drawings, and calculations to King County for review on demand, with reasonable notice and intervals.
4. Mechanical Systems are to be designed such that their maintenance will not require interruption to the activities of the data center. If work over King County equipment or servers is required, all reasonable protective measures shall be coordinated with the tenant to ensure the safety of the equipment and servers.
5. Tenant equipment management will comply with other provisions of the lease.

Electrical

1. Electrical system design must provide a capacity equal to 150 watts per square foot for entire second floor data center leased area. This capacity excludes general purpose loads associated with building and mechanical systems. Office area power consumption must be in accordance with NFPA 70 and applicable local codes.
2. Provide verifiable means that electrical systems, inclusive but not limited to standby power generation and distribution systems, are designed, maintained and operated on an N+1 capability, except during scheduled maintenance or unplanned events not reasonably foreseeable by the landlord. Maintain detailed design data and calculations that define design requirements of all tenants whose systems are connected to systems serving King County spaces. Provide design data, details, drawings, and calculations to King County for review on demand, with reasonable notice and intervals.
3. Provide integral Uninterrupted Power Supply, power quality monitoring devices in distribution panels 52-A1, 52-B1, 52-C1, and 52-D1. Monitoring devices shall continuously monitor the state of the power delivered to the data center file servers and related network components. The monitoring system shall store minimum 30-days of recorded data that can be downloaded by the Tenant via network connection, and electronically analyzed and evaluated in combination with the ITI (CBEMA) curve (**Attachment B**) to assess power system voltage fluctuations, short- and long-term excursions, and the specific impact the disturbance places on the data center equipment at risk. Equip power devices with all sensors required to monitor:
 - a. Volts: L-L, L-N
 - b. Current: A, B, C, N, G
 - c. Power: Watt, VAR, VA
 - d. Power Factor: Apparent/Displacement
 - e. Frequency: Hertz
 - f. THD: Amperes/Volts (L-L, L-N)
 - g. Demand Values: kW, kVAR, kVA, Amperes
 - h. Event Logging: 500 minimum
 - i. Disturbance Recording: 60 Cycles per Event
4. Provide Normal and Backup power to all leased areas on a 24/7/365 basis with no interruptions, according to **Attachment 'B'**. Downtime (defined as the loss of Normal and Backup power) shall be limited to 1.6 hours annually with an uptime of 99.98%.

5. Provide video surveillance of building entrances, adjacent corridors & suite entrances. Provide reports of entry logs and camera footage from adjacent corridors and suite entrances to King County leased space with reasonable notice. Cooperate with King County vendors during the installation of King County surveillance and access control systems.

Communications

1. Data Center grounding shall be designed in accordance with IEEE 1100-2005: recommended wiring and grounding system design practices; applicable to telecommunications system grounding, industrial system grounding, and noise control.
2. Provide all telecommunications infrastructure work in accordance with **Attachment 'C' and Attachment 'D' and Attachment 'E'**.

END

Attachments:

- 'A' Environmental Performance
- 'B' ITI Curve Application Note
- 'C' KC Data Center Design Criteria -Telecommunications
- 'D' Standardized Racking Specifications
- 'E' Sabey Data Center Architecture
- 'F' Design Development plans dated _____
- 'G' Design Development comments
- 'H' Design Narrative

King County Data Center - Essential Performance Requirements - Attachment A

Sabey Revised

03/28/08

Environmental Performance Range

		Space	Occupancy, No. of people	Temperature Degrees F	Relative Humidity, %	Noise Level NC
A	Critical	Server Room and Tape Storage	10	** 60-78	30-70	55
B		Main Frame	2	** 60-78	30-70	55
C		UPS Room	2	NIC	NIC	NIC
D		MDF Room	2	** 60-78	30-70	55
E		IDF Room #1	2	** 60-78	30-70	55
F		IDF Room #2	2	** 60-78	30-70	55
G		Command (Network Operations Center)	6	** 60-78	30-70	40
H		Printer Room	4	** 66-74	*** 30-70	40
I		Paper storage room	2	NA	NA	40
J		Office and Locker Room	25	NA	NA	40
K	Break room	4	NA	NA	40	
	non-critical					

* 1 Tenant Equipment excluded from Noise Level limits

** 2 The temperature setpoint shall be 70 degrees F, and maintained within +/- 3 degrees fahrenheit

*** 3 The Humidity setpoint for this space shall be set by Tenant and maintained at 40% +/- 5% RH
The Landlord will submit alternate pricing for design options that will provide humidity Performance Requirement

ATTACHMENT 'A'

King County Data Center - Essential Performance Requirements

Environmental Performance Range

03/20/08

		Space	Occupancy, No. of people	Temperature Degrees F	Relative Humidity, %	Noise Level NC
A	Critical	Raised Floor - Server Room and Tape Storage	10	68 +/-2	45 +/-10	45
B		Main Frame	2	68 +/-2	45 +/-10	45
C		UPS Room	2	72 +/-2	25 - 55	45
D		MDF Room	2	68 +/-2	45 +/-10	45
E		IDF Room #1	2	68 +/-2	45 +/-10	45
F		IDF Room #2	2	68 +/-2	45 +/-10	45
G		Command (Network Operations Center)	6	72 +/- 2	40 +/-10	35
H		Printer Room	4	72 +/- 2	40 +/-10	50
I		Paper storage room	2	72 +/- 2	30 +/-10	50
J		Office and Locker Room	25	72 +/- 2	30 +/-15	40
K		Break room	4	72 +/- 2	30 +/-15	35

Tenant Equipment excluded from Noise Level limits

ATTACHMENT 'B'

ITI (CBEMA) CURVE APPLICATION NOTE

The ITI (CBEMA) Curve, included within this Application Note, is published by Technical Committee 3 (TC3) of the Information Technology Industry Council (ITI, formerly known as the Computer & Business Equipment Manufacturers Association). It is available at <http://www.itic.org/technical/iticurv.pdf>.

1) SCOPE

The ITI (CBEMA) Curve and this Application Note describe an AC input voltage envelope which typically can be tolerated (no interruption in function) by most Information Technology Equipment (ITE). The Curve and this Application Note comprise a single document and are not to be considered separately from each other. They are not intended to serve as a design specification for products or AC distribution systems. The Curve and this Application Note describe both steady-state and transitory conditions.

2) APPLICABILITY

The Curve and this Application Note are applicable to 120V nominal voltages obtained from 120V, 208Y/120V, and 120/240V 60Hz systems. Other nominal voltages and frequencies are not specifically considered and it is the responsibility of the user to determine the applicability of these documents for such conditions.

3) DISCUSSION

This section provides a brief description of the individual conditions which are considered in the Curve. For all conditions, the term "nominal voltage" implies an ideal condition of 120V RMS, 60Hz.

Seven types of events are described in this composite envelope. Each event is briefly described in the following sections, with two similar line voltage sags being described under a single heading. Two regions outside the envelope are also noted. All conditions are assumed to be mutually exclusive at any point in time, and with the exception of steady-state tolerances, are assumed to commence from the nominal voltage. The timing between transients is assumed to be such that the ITE returns to equilibrium (electrical, mechanical, and thermal) prior to commencement of the next transient.

3.1) Steady-State Tolerances

The steady-state range describes an RMS voltage which is either very slowly varying or is constant. The subject range is

$\pm 10\%$ from the nominal voltage. Any voltages in this range may be present for an indefinite period, and are a function of normal loadings and losses in the distribution system.

3.2) Line Voltage Swell

This region describes a voltage swell having an RMS amplitude of up to 120% of the RMS nominal voltage, with a duration of up to 0.5 seconds. This transient may occur when large loads are removed from the system or when voltage is supplied from sources other than the electric utility.

3.3) Low-Frequency Decaying Ringwave

This region describes a decaying ringwave transient which typically results from the connection of power-factor-correction capacitors to an AC distribution system. The frequency of this transient may range from 200Hz to 5KHz, depending upon the resonant frequency of the AC distribution system. The magnitude of the transient is expressed as a percentage of the peak 60Hz nominal voltage (not the RMS value). The transient is assumed to be completely decayed by the end of the half-cycle in which it occurs. The transient is assumed to occur near the peak of the nominal voltage waveform. The amplitude of the transient varies from 140% for 200Hz ringwaves to 200% for 5KHz ringwaves, with a linear increase in amplitude with increasing frequency. Refer to Figure 1 for an example of a typical waveform.

FIGURE 1

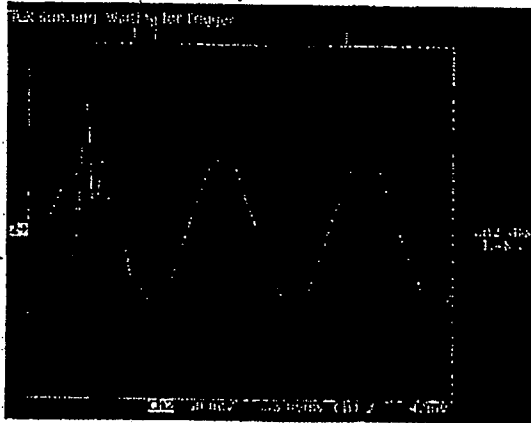

TYPICAL LOW FREQUENCY DECAYING RINGWAVE

3.4) High-Frequency Impulse and Ringwave

This region describes the transients which typically occur as a result of lightning strikes. Wave shapes applicable to this transient and general test conditions are described in ANSI/IEEE C62.41-1991. This region of the curve deals with both amplitude and duration (energy), rather than RMS amplitude. The intent is to provide an 80 Joule minimum transient immunity.

3.5) Voltage Sags

Two different RMS voltage sags are described. Generally, these transients result from application of heavy loads, as well as fault conditions, at various points in the AC distribution system. Sags to 80% of nominal (maximum deviation of 20%) are assumed to have a typical duration of up to 10 seconds, and sags to 70% of nominal (maximum deviation of 30%) are assumed to have a duration of up to 0.5 seconds.

3.6) Dropout

A voltage dropout includes both severe RMS voltage sags and complete interruptions of the applied voltage, followed by immediate re-application of the nominal voltage. The interruption may last up to 20 milliseconds. This transient typically results from the occurrence and subsequent clearing of faults in the AC distribution system.

3.7) No Damage Region

Events in this region include sags and dropouts which are more severe than those specified in the preceding paragraphs, and continuously applied voltages which are less than the lower limit of the steady-state tolerance range. The normal functional state of the ITE is not typically expected during these conditions, but no damage to the ITE should result.

3.8) Prohibited Region

This region includes any surge or swell which exceeds the upper limit of the envelope. If ITE is subjected to such conditions, damage to the ITE may result.

ITI (CBEMA) Curve
(Revised 2000)

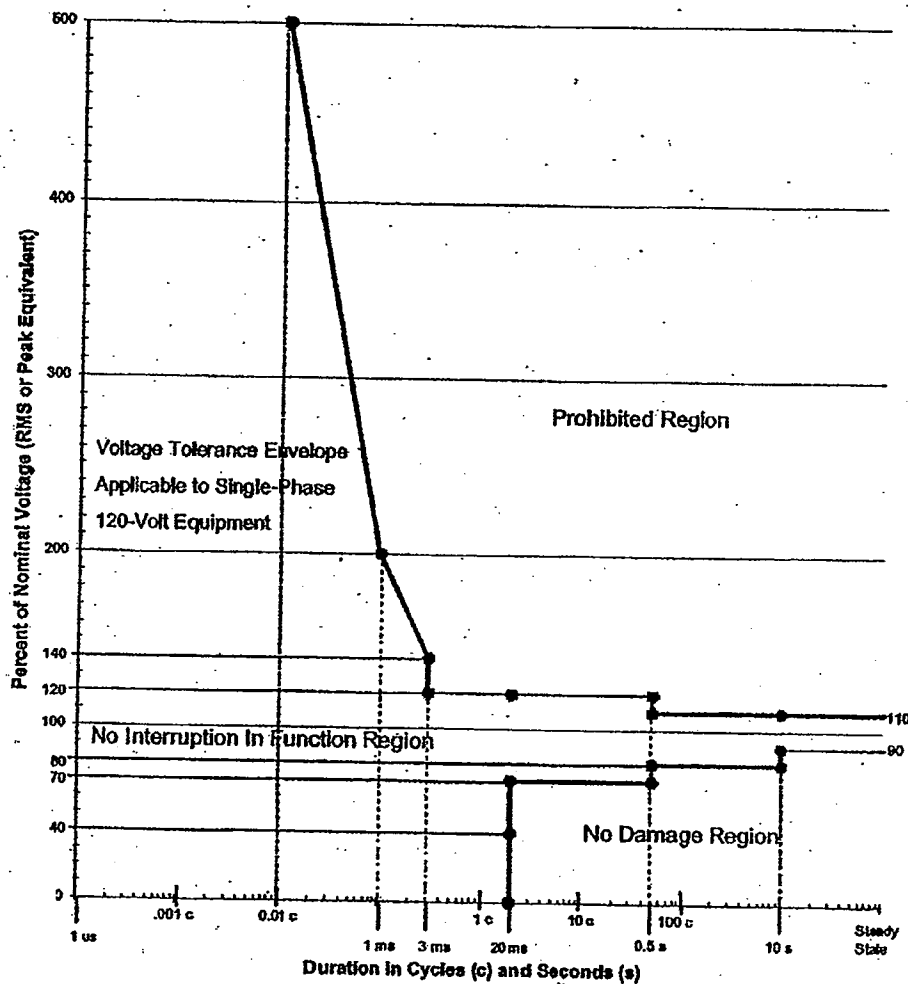

Published by:

Information Technology Industry Council (ITI)
1250 Eye Street NW Suite 200 Washington DC 20005
202-737-8888
<http://www.itic.org>

May be reprinted with permission.

ATTACHMENT 'C'

Telecommunications - General 2

1.0 Scope 2

2.0 Standards And Codes 2

3.0 Data Center Design Overview 2

 3.1 General 2

 3.2 Tiering 2

 3.3 Data Center Communications Systems 2

4.0 Data Center Spaces 3

 4.1 General 3

 4.2 Data Center Structure 3

5.0 Data Center Cabling Systems 4

 5.1 Horizontal Cabling 4

 5.2 Backbone Cabling 5

6.0 Cabling Pathways 5

 6.1 General 5

 6.2 Telecommunications Entrance Pathways 6

 6.3 Security for Data Center Cabling 6

 6.4 Separation of Power and Telecommunications Cables 6

 6.5 Overhead Cable Trays 6

7.0 Data Center Cabling System Infrastructure 7

 7.1 General 7

 7.2 Telecommunications Cabling 7

 7.3 Cable and Equipment Color Codes 8

 7.4 Equipment Racks 9

 7.5 Equipment Cabinets 9

 7.6 Backboards 9

 7.7 Connector Blocks (Systemax VisiPatch 360 System) 10

 7.8 Patch Panels (Category 6) 10

 7.9 Fiber Optic Patch Panels 10

 7.10 Optical Fiber and Copper Patch Cords for Patch Panels 11

 7.11 Telecommunications Outlet/Connector Assemblies 11

 7.12 Grounding and Bonding Products 12

 7.13 Firestopping Material 13

 7.14 Tests, Inspections, and Verifications 13

 7.15 Unit Counts – Contractor Furnished and Installed Equipment 14

TELECOMMUNICATIONS - GENERAL

1.0 SCOPE

- A. The purpose of this document is to provide requirements and guidelines for the design and installation of a consolidated Data Center for King County.
- B. This section is intended for use by designers who need a comprehensive understanding of the data center cabling system and network design.

2.0 STANDARDS AND CODES

- A. Applicable industry codes, standards, or publications referenced hereinafter apply to equipment, materials, and construction covered herein.
- B. The minimum requirements of the latest edition of International Building Code (IBC), NFPA 70, National Electrical Code (NEC), and ANSI/TIA/EIA Communications Standards shall apply unless more stringent requirements are specified and/or dictated.

3.0 DATA CENTER DESIGN OVERVIEW

3.1 General

- A. The data center telecommunications cabling and pathway system shall include permanently installed backbone and horizontal cabling, horizontal and backbone pathways, service entrance facilities, work area pathways, telecommunications outlet assemblies, conduit, raceway, and hardware for terminating and interconnecting cabling.
- B. The horizontal system shall be wired in a star topology from the horizontal cross-connect (IDF) or the main cross-connect (MDF) to the workstation outlets.
- C. The backbone cabling and pathway system includes intrabuilding interconnecting cabling, pathway, and terminal hardware. The intrabuilding backbone provides connectivity from the IDFs and Zone Cabinets to the MDF. The backbone system shall be wired in a star topology with the MDF at the center or hub of the star.
- D. Secure pathways for routing outside plant (interbuilding backbone cables) from the facility entrance rooms to the MDF shall be provided as described under Cabling Pathways hereinafter.

3.2 Tiering

- A. The data center design shall meet the requirements for a Tier III classification as defined by The Uptime Institute, Inc. for a concurrently maintainable site infrastructure.
- B. Tier III level capability allows for any planned site infrastructure activity without disrupting the computer hardware operation in any way. Planned activities include preventive and programmable maintenance, repair and replacement of components, addition or removal of capacity components, testing of components and systems, and more. Sufficient capacity and distribution must be available to simultaneously carry the load on one path while performing maintenance or testing on the other path.

3.3 Data Center Communications Systems

- A. Refer to network overview, Attachment E: Sabey Data Center Architecture.
- B. Required systems include but are not limited to:

1. Data Communications
2. Voice Communications
3. Dual-band transceiver with distributed antennas to facilitate cell phone/PCS communications indoors
4. Optical fiber interconnects
5. Wireless connectivity to KCPAN
6. Wireless connectivity to KCWAN

4.0 DATA CENTER SPACES

4.1 General

A. Spaces dedicated to the support of the telecommunications infrastructure includes:

1. The entrance rooms (MPOE)
2. Main distribution area (MDF)
3. Horizontal distribution area (IDF)
4. and equipment distribution area (EDA or Zone).

4.2 Data Center Structure

A. Entrance Rooms

1. The entrance rooms are the interface between the data center structured cabling system and interbuilding cabling, both access provider and King County owned. These rooms include the access provider demarcation hardware and equipment, and King County outside plant cable interconnects. Multiple entrance rooms are required to provide redundancy for King County and access provider-provisioned circuits.
2. The entrance room locations are outside the data center area. The designer shall confirm exact locations of the entrance rooms and include pathways between the entrance rooms and the MDF.
3. The entrance rooms interface with the equipment distribution area through the MDF.

B. Main Distribution Area (MDF)

1. This space is a room labeled "MDF" and is located inside the Data Center/Server Room. The main distribution area includes the main cross-connect (MDF), which is the central point of distribution for the data center structured cabling system, and point of interface to broadband services including wide area (WAN) and metropolitan area (MAN) networks.

2. The MDF serves IDFs or zone distribution cabinets within the equipment distribution area, and IDFs that support office spaces, the Command Center/NOC, and other external support rooms.

C. Horizontal Distribution Area (IDF)

1. The horizontal distribution area is used to serve offices and equipment areas when the horizontal crossconnect is not located in the main distribution area. The horizontal distribution area includes the IDF equipment cabinets (Zone or Zero Cabinets), which is the distribution point for cabling to the equipment distribution areas (EDAs).
2. The horizontal distribution areas are located on the first floor and inside the equipment distribution area. The horizontal distribution area includes LAN switches, SAN switches, and Keyboard/Video/Mouse (KVM) switches, etc. for the end equipment located in the equipment distribution areas.
3. Several IDFs are required.

D. Equipment Distribution Area (EDA)

1. The equipment distribution area is the space allocated for equipment cabinets housing the computer systems and equipment. These areas shall not serve the purposes of an entrance room, main distribution area or horizontal distribution area.
2. Zone or Zero Cabinets shall be provided as interconnection points for the horizontal cabling (IDFs) located between the MDF and the equipment distribution area to allow frequent reconfiguration and flexibility.

5.0 DATA CENTER CABLING SYSTEMS

5.1 Horizontal Cabling

A. Topology:

1. The horizontal cabling shall be installed in a star topology. Each mechanical termination in the equipment distribution area shall be connected to a horizontal cross-connect in the horizontal distribution area or main cross-connect in the main distribution area via a horizontal cable.
2. Horizontal cabling shall contain no more than one consolidation point in the zone distribution area between the horizontal cross-connect in the horizontal distribution area and the mechanical termination in the equipment distribution area.

B. Horizontal Cabling Distances:

1. The horizontal cabling distance is the cable length from the mechanical termination of the media at the horizontal cross-connect in the horizontal distribution area or the main distribution area to the mechanical termination of the media in the equipment distribution area. The maximum horizontal distance shall be 90 m (295 ft), independent of media type.
2. The maximum channel distance including equipment cords shall be 100 m (328 ft).
3. Horizontal cable distances in the Data Center/Server Room shall be reduced to compensate for longer equipment cords in the data center distribution areas.

5.2 Backbone Cabling

- A. The backbone cabling shall allow network reconfiguration and future growth without disturbance of the backbone cabling.
- B. The backbone cabling shall support different connectivity requirements, including both the network and physical console connectivity such as local area networks, wide area networks, storage area networks, computer channels, and equipment console connections.
- C. Topology:
 1. The backbone cabling shall use the hierarchical star topology wherein each IDF is cabled directly to the MDF.
 2. There shall be no more than one hierarchical level of crossconnect in the backbone cabling.

6.0 CABLING PATHWAYS

6.1 General

- A. Cabling pathways shall be designed in accordance with TIA/EIA-569-A, TIA-942, and as specified hereinafter.
- B. Cabling pathway components include but are not limited to: outlet boxes, conduits, wireways, cable trays, open cable supports and other accessories required to provide an end-to-end pathway for routing and supporting optical fiber and copper telecommunications cables.
 1. Horizontal Pathway: Cable pathways from the work area to an IDF or the MDF shall be designed to comply with cabling length limitations in accordance with TIA/EIA-568-B.1.
 2. Backbone Pathways: Cable pathways from the facility entrance rooms to the MDF (Interbuilding backbone cabling), and from the IDFs to the MDF (Intrabuilding backbone cabling) shall be installed in accordance with TIA/EIA-568-B.2 and TIA/EIA-568-B.3 for copper and optical fiber media respectively.
- C. Provide (2) 4" Conduits with innerducts and pull ropes installed between the first floor IDF and the MDF.

- D. Comply with the pathway security requirements. See Security for Data Center Cabling paragraph hereinafter.

6.2 Telecommunications Entrance Pathways

- A. Provide (1) 4" Conduit with innerduct and pull rope installed between the North Entrance Room and the MDF.
- B. Provide (1) 4" Conduit with innerduct and pull rope installed between the South Entrance Room and the MDF.
- C. Comply with the pathway security requirements below.

6.3 Security for Data Center Cabling

- A. Cabling associated with the data center shall not be routed through spaces accessible by the public or by other tenants of the building. Route cables enclosed in conduit or other secure pathways. Any maintenance access doors, pull boxes, or splice boxes located between the MPOEs and MDF shall be equipped with a lock.
- B. Any maintenance holes on building property or under control of the facility owner shall be locked and monitored by the data center security system using a camera and remote alarm.
- C. Entrance to utility tunnels, vaults, or rooms used for telecommunications entrance rooms and other data center cabling shall be locked. If the tunnels, vaults, or rooms are used by multiple tenants or cannot be locked, telecommunications cabling shall be in rigid metal conduit or other secure pathway

6.4 Separation of Power and Telecommunications Cables

- A. A separation of 12" between power and telecommunications cables shall be maintained to minimize longitudinal coupling between power cables and twisted-pair copper cables.
- B. Refer to NFPA 70, article 800 or applicable WAC code for additional installation requirements.

6.5 Overhead Cable Trays

- A. Overhead cable trays shall be used to distribute network cabling to equipment cabinets within the equipment distribution area and in the MDF.
- B. Coordinate cable tray routes with equipment cabinet layouts to facilitate power and communication cable distribution.
- C. Cable Tray construction shall comply with NEMA VE 1.
- D. Cable trays shall form part of the telecommunications cable pathway system, and shall be Basket-Type, nominal 4 inch depth. Cable tray widths shall be as determined by the designer to suit cabling applications.
- E. Cable trays shall be provided as complete systems that include:
 - 1. Splice plates
 - 2. End plates
 - 3. Dropouts
 - 4. and miscellaneous assembly and support hardware.

- F. Edges, fittings, and hardware shall be finished free from burrs and sharp edges. Fittings shall have not less than load-carrying ability of straight tray sections and shall have manufacturer's minimum standard radius.
- G. Cable trays located under access floors shall be the ventilated type to allow airflow. See ANSI/TIA-569-B for further cable tray design considerations.
- H. Metallic cable trays shall be bonded to the data center grounding infrastructure.

7.0 **DATA CENTER CABLING SYSTEM INFRASTRUCTURE**

7.1 **General**

- A. Cabling and interconnecting hardware and components for telecommunications systems shall be UL listed or third party independent testing laboratory certified, and shall comply with NFPA 70 and conform to the requirements specified herein.
- B. UL or third party certified. Where equipment or materials are specified to conform to industry and technical society reference standards of the organizations, submit proof of such compliance.
- C. The label or listing by the specified organization will be acceptable evidence of compliance. In lieu of the label or listing, a certificate from an independent testing organization, competent to perform testing, and approved by the Owner. The certificate shall state that the item has been tested in accordance with the specified organization's test methods and that the item complies with the specified organization's reference standard.
- D. Provide a system of telecommunications cabling and pathway components complete with outlets, cables, connecting hardware and telecommunications cabinets/racks.

7.2 **Telecommunications Cabling**

- A. Cabling shall be UL listed for the application and shall comply with TIA/EIA-568-B.1, TIA/EIA-568-B.2, TIA/EIA-568-B.3, and NFPA 70. Labeling system for cabling shall be in accordance with TIA/EIA-606-A and UL 969.
- B. Backbone Cabling
 - 1. Backbone Copper:
 - a. Comply with ICEA S-90-661, TIA/EIA-568-B.1, TIA/EIA-568-B.2, NEMA WC 66 and UL 444
 - b. Copper backbone cable shall be solid conductor, 24 AWG, 100 ohm, 200-pair UTP (Unshielded twisted pair), formed into 25 pair binder groups covered with a white thermoplastic jacket. Confirm exact pair densities required during design phase.
 - c. Cable shall be imprinted with manufacturer's name or identifier, flammability rating, gauge of conductor, transmission performance rating (category designation) at regular intervals not to exceed 2 feet.
 - d. Cable shall be communications general purpose (CM or CMG), communications plenum (CMP) or communications riser (CMR) rated cabling in accordance with NFPA 70. Type CMP and CMR may be substituted for type CM or CMG and type CMP may be substituted for type CMR in accordance with NFPA 70.

- e. Color coding shall comply with industry standards for 25 pair cables.
- 2. Backbone Optical Fiber:
 - a. Comply with ICEA S-83-596, TIA/EIA-568-B.3, UL 1666 and NFPA 70. Cable outer jacket shall be imprinted at regular intervals not to exceed 40 inches with fiber count, fiber type and aggregate length.
 - b. Optical fiber cables shall be tight buffered and comply with the following:
 - 1. TIA/EIA-492AAAA-A, multimode, 50/125-um diameter
 - 2. TIA/EIA-492CAAA, single-mode, 8.3/125-um diameter
 - c. Backbone cables shall be 24-strand unless other strand densities are indicated.
 - d. Cable shall be nonconductive optical fiber general purpose (OFN or OFNG), nonconductive optical fiber plenum cable (OFNP), and nonconductive optical fiber riser cable (OFNR) rated cable in accordance with NFPA 70 and UL 910.
 - e. Type OFNP or OFNR may be substituted for type OFN or OFNG and type OFNP may be substituted for type OFNR in accordance with NFPA 70.

C. Horizontal Cabling:

1. Horizontal Copper

- a. Horizontal copper cable shall comply with TIA/EIA-568-B.2, UL 444, NEMA WC 66, ICEA S-90-661 UTP (unshielded twisted pair), 100 ohm.
- b. Construct cables using four each individually twisted pair, 24 AWG conductors, Category 6, with a thermoplastic jacket.
- c. Cable shall be imprinted with manufacturers name or identifier, flammability rating, gauge of conductor, transmission performance rating (category designation) at regular intervals not to exceed 2 feet.
- d. Cables shall be communications general purpose (CM or CMG), communications plenum (CMP) or communications riser (CMR) rated in accordance with NFPA 70. Type CMP and CMR may be substituted for type CM or CMG and type CMP may be substituted for type CMR in accordance with NFPA 70.

7.3 Cable and Equipment Color Codes

- A. Cross-Connect Field Color Codes shall adhere to TIA/EIA-606-A color coding standards in accordance with the following:

Orange	Demarcation point
Green	Network connections
Purple	Common equipment, private branch exchange (PBX)
White	First-level backbone (e.g., MDF to an IDF)
Gray	Second-level backbone (e.g., EDA to an IDF)
Blue	Horizontal cable

Yellow Miscellaneous (auxiliary, alarms, security)
Red Reserved for future use (also, key telephone systems).

B. Cable Terminations

1. Include termination materials, hardware and equipment to terminate horizontal and backbone cabling in the telecommunications entrance facility and telecommunication equipment rooms.
2. Color coding of telecommunications interconnecting hardware shall be in accordance with TIA/EIA-606-A.

7.4 Equipment Racks

- A. Provide 19" two-post universal racks equipped in accordance with the general guidelines section of the King County OIRM standardized device racking specifications. See Attachment D.
- B. Provide rack quantities as specified hereinafter. See Unit Counts – Contractor Furnished and Installed Equipment

7.5 Equipment Cabinets

- A. Provide equipment cabinets in accordance with the general guidelines for 28" and 32" wide cabinet systems section of the King County OIRM standardized device racking specifications. See Attachment D.
- B. Provide cabinet quantities as specified hereinafter. See Unit Counts – Contractor Furnished and Installed Equipment.

7.6 Backboards

- A. Backboards shall be fire rated, interior grade plywood 3/4 inch thick 4 by 8 feet. Backboards shall be installed on a minimum of two walls in the telecommunication spaces.
- B. Cable guides of ring or bracket type shall be mounted on backboards for cable management.

7.7 Connector Blocks (Systemax VisiPatch 360 System)

- A. Specify a complete system of connector blocks for copper twisted-pair backbone, voice, and auxiliary circuit terminations including but not limited to:
 - 1. Wall or rack mounted VisiPatch units
 - 2. Vertical and horizontal wire management throughout; wire management for the VisiPatch wall field shall be required and specified with backboard elevations.
 - 3. VisiPatch units for horizontal cable terminations
 - 4. VisiPatch units for copper backbone and PBX extension terminations
 - 5. VisiPatch units for network interface cable terminations
 - 6. and space for future VisiPatch units.
- B. The VisiPatch units for the workstation terminations and the copper PBX extensions shall occupy the bottom two thirds (2/3) of the VisiPatch field. Allow space on the right-hand side of installations for future units.
- C. The top one third (1/3) of the VisiPatch field is to be used to terminate backbone and network interface cables from the rack mounted network equipment.
- D. Patch cables shall be VisiPatch type, and used to cross-connect the upper one third (1/3) to the lower two thirds (2/3).
- E. Allow for the number of horizontal and backbone cables terminated on the block plus 25 percent spare.

7.8 Patch Panels (Category 6)

- A. Comply with TIA/EIA-568-B.1 and TIA/EIA-568-B.2. Panels shall be third party verified and shall comply with EIA/TIA Category 6 requirements. Panel shall be constructed of aluminum and shall be cabinet, rack, and wall mountable and compatible with EIA-310-D 19 inch mounting. Panels shall accommodate 48 non-keyed, 8-pin modular ports, wired to T-568B wiring designation.
- B. Patch panels shall terminate the data center cabling on Type 110 IDCs and shall utilize a printed circuit board interface. The rear of each panel shall have incoming cable strain-relief and routing guides. Panels shall have each port factory numbered and be equipped with laminated plastic nameplates above each port.

7.9 Fiber Optic Patch Panels

- A. Compatible with EIA-310-D 19 inch equipment racks; constructed of steel or aluminum, and suitable for cabinet or rack mounting; equip with low-density TIA/EIA-604-10A type LC adapters with thermoplastic alignment sleeves for use with multimode or single-mode optical fibers.
- B. The front of the panel shall have a key-lockable hinged door. The rear of each panel shall have a cable management tray a minimum of 8 inches deep with removable cover, incoming cable strain-relief and routing guides. Panels shall have each adapter factory numbered and be equipped with laminated plastic nameplates above each adapter.

- C. Fiber optic panels shall be labeled in a consistent manner with descriptive and unique labels indicating "to" and "from" on each end. Individual fiber connectors shall be labeled with the same label on each end. Labeling scheme shall be approved by King County prior to use.

7.10 Optical Fiber and Copper Patch Cords for Patch Panels

- A. Patch cords shall meet minimum performance requirements specified in TIA/EIA-568-B.1, TIA/EIA-568-B.2 and TIA/EIA-568-B.3.
- B. Verify quantities, lengths, and jacket colors with the owner during the design phase.

7.11 Telecommunications Outlet/Connector Assemblies

A. Copper Cable Outlet/Connectors

1. Outlet/connectors shall comply with FCC Part 68, TIA/EIA-568-B.1, and TIA/EIA-568-B.2.
2. UTP outlet/connectors shall be UL 1863 listed, non-keyed, 8-pin modular jacks, constructed of high impact rated thermoplastic housing and shall be third party verified and shall comply with TIA/EIA-568-B.2 Category 6 requirements.
3. Outlet/connectors provided for UTP cabling shall meet or exceed the requirements for the cable provided.
4. Outlet/connectors shall be terminated using a Type 110 IDC PC board connector, color-coded for both T-568A and T-568B wiring designations.
5. Each outlet/connector shall be wired T-568B.
6. UTP outlet/connectors shall comply with TIA/EIA-568-B.2 for 200 mating cycles.
7. Each workstation outlet shall have a minimum of three (3) RJ-45 jacks on a four (4) jack faceplate. Category 6 cables shall be run to each jack in the faceplate.
8. The jacks shall be labeled as "A", "B" & "C", prefaced by the communications faceplate numbering scheme proposed for the building, in accordance with the King County Labeling Standard.
9. All RJ-45 jacks shall be "universal", allowing voice or data to be used in any combination.
10. Cable length shall not exceed ninety (90) meters of installed cable from the workstation jack to the IDF patch panel.

B. Optical Fiber Adapters

1. Optical fiber adapters shall be type LC in accordance with TIA/EIA-604-10A.
2. Comply with EIA TIA-455-21-A for 500 mating cycles.

C. Optical Fiber Connectors:

1. Comply with EIA TIA-455-21-A. Optical fiber connectors shall be type LC in accordance with TIA/EIA-604-10A with thermoplastic ferrule, compatible with 50/125 multimode, and 8.3/125 single-mode fiber.
2. Optical fiber connectors shall provide a maximum attenuation of 0.3 dB with less than a 0.2 dB change after 500 mating cycles.

D. Faceplates:

1. Telecommunications cover plates shall comply with UL 514C, and TIA/EIA-568-B.1, TIA/EIA-568-B.2, TIA/EIA-568-B.3; constructed of high impact thermoplastic material to match color of receptacle/switch cover plates.
2. Labeling shall be in accordance with the King County Labeling Standard.

7.12 **Grounding and Bonding Products**

A. Grounding shall be in accordance with UL 467, TIA J-STD-607-A, and NFPA 70. Components shall be identified as required by TIA/EIA-606-A.

B. Bonding Conductors

1. ASTM B 1, solid copper wire for sizes No. 8 AWG and smaller diameter; ASTM B 8, Class B, stranded copper wire for sizes No. 6 AWG and larger diameter.
2. Bonding conductors shall be installed for each panelboard, sized per NEC 250.122
3. Equipment Bonding Conductors:
 - a. 4 AWG or larger bonding conductor to each column in the equipment distribution area (EDA).
 - b. 6 AWG or larger bonding conductor to each cable ladder, cable tray, and cable wireway entering EDA
 - c. 6 AWG or larger bonding conductor to each conduit, water pipe, and duct entering EDA
 - d. 6 AWG or larger bonding conductor to each computer or telecommunications cabinet, rack, or frame. Do not bond racks, cabinets, and frames serially.

C. Telecommunications Grounding and Bonding (TIA J-STD-607-A)

1. A Telecommunication Bonding Backbone (TBB) is required between the telecommunications main grounding busbar (TMGB) and all telecommunications grounding busbars (TGBs). Size in accordance with the following:

<u>TBB length linear feet</u>	<u>TBB Size (AWG)</u>
Less than 13	6
14 - 20	4
21 - 26	3
27 - 33	2
34 - 41	1
42 - 52	1/0
53 - 66	2/0
Greater than 66	3/0

2. TBB conductor type: insulated copper
3. A Bonding Conductor for Telecommunications is required between the telecommunications main grounding busbar (TMGB) and the electrical service ground in accordance with TIA J-STD-607-A. The bonding conductor for telecommunications shall be sized the same as the TBB.
4. Telecommunications Grounding Busbars: corrosion-resistant copper grounding busbar electrotin plated for reduced contact resistance.
 - a. Provide a telecommunications main grounding busbar (TMGB) in the telecommunications entrance room(s) and a (TGB) in all other telecommunications equipment areas and enclosures. Refer to Telecommunications section, 4.2 Data Center Structure, for area descriptions
 - b. Size the TMGB and the TGBs in accordance with the immediate application requirements and with consideration of future growth.
 - c. Minimum dimensions: 0.25 in thick x 4 in wide for the TMGB and 2 in wide for TGBs with lengths as required; Listed by a nationally recognized testing laboratory.

7.13 Firestopping Material

- A. Firestop all locations where cables penetrate fire rated surfaces. Materials and methods used shall be acceptable to the code authority having jurisdiction and shall maintain the fire integrity of the wall, floor, or ceiling surface penetrated

7.14 Tests, Inspections, and Verifications

- A. Factory Reel Tests: Require documentation of the testing and verification actions taken by manufacturers to confirm compliance with TIA/EIA-568-B.1, TIA/EIA-568-B.3; and TIA/EIA-526-7 for single mode optical fiber, and TIA/EIA-526-14A for multimode optical fiber cables.

7.15 Unit Counts – Contractor Furnished and Installed Equipment

Location/Description	Qty
Data Center Equipment Room	
Chatsworth TeraFrame Locking Cabinets 24"	80
Chatsworth TeraFrame Locking Cabinets 32"	8
Cabinet Distribution Units 208V, 3-phase	190
Horizontal manager Chatsworth 30339-719	40
Main Distribution Area (MDF)	
Chatsworth 2-post	12
2-post shelves	30
2-post cable trough	12
Vertical cable management Panduit PRV12	13
Vertical cable management (Door) - Panduit PRD12	26
cable management Panduit PRD12	43
horizontal manager Chatsworth 30339-719	80
VisiPatch to VisiPatch patch cables Cat6 7'	250
VisiPatch to VisiPatch patch cables single pair 7' and 10'	110
Horizontal Distribution Areas (IDFs)	
First Floor:	
Chatsworth 2-post	1
2-post shelves	2
2-post cable trough	1
Vertical cable management - Panduit PRV12	2
Vertical cable management (Door) - Panduit PRD12	4
cable management Panduit PRD12	2
Horizontal manager Chatsworth 30339-719	4
VisiPatch to VisiPatch patch cables Cat6 7'	100
VisiPatch to VisiPatch patch cables single pair 7' and 10'	50

END OF SECTION

10



01



King County

**King County
Office of Information and Resource Management**

**Standardized Device Racking Specifications
For Sabey Data Center.**

Version 2.0 March 14, 2008

OIRM Standardized Device Racking Specifications for Sabey Data Center

Revision History:

Date of Change	Person Making Change	Brief Description of Change	Updated Version Number
3/20/2007	R. Gideon	Creation of document to use in data center specifications	1.1
5/18/2007	R. Gideon	Updated to modify vertical cable management and add more products.	1.2
10/18/2007	R. Gideon	Updated to add server cabinets for new Main data center; added IP KVM information.	1.3
10/30/2007	R. Gideon	Added 30" Wide F-series Teraframe.	1.4
2/13/2008	R. Gideon	Added Plenafill	1.5
3/6/2008	R. Gideon	Made new DC specific and added better descriptions.	1.6
3/14/2008	C. Boudreau/R. Kaiser/M. Van Horn	Final edits	2.0

OIRM Standardized Device Racking Specifications for Sabey Data Center

Preface

This document is put forth to detail the specifications for standardized computer racking for use in the new King County OIRM data center facility.

Moving to a standardized racking method will allow OIRM to better support its customers and ensure uniformity to maintain cooling and cable management design.

Racking specifications included in this document cover the following:

- 19" Two-Post Universal Rack, cable management and accessories

- 28" (700mm) Wide Cabinet Systems, cable management and accessories for servers

- 32" (800mm) Wide Cabinet Systems, cable management and accessories for network gear.

OIRM Standardized Device Racking Specifications for Sabey Data Center

General Guidelines for 19" Two-post Universal Racks

- A. Equip each rack with vertical and horizontal cable management channels, top and bottom cable troughs, grounding lug and two surge protected power strip with IEC-C13 receptacles fed from diverse 208v 30A sources.
- B. Vertical cabling section, 12" wide: Panduit PRV12 installed between and at the end of each rack of a multi-rack installation.
- C. Racks shall be laid out in a way that allows future expansion and access to all sides with a minimum of forty-eight inches (48") of clear space in front and thirty-six inches (36") in the rear.
- D. There shall be multiple twelve inch (12") cable runways above the row of racks and extending to the backboard. These rack and cable runways shall be used for data networking equipment and patch cables.
- E. Rack and associated equipment shall be equipped with seismic bracing. Rack base shall be gusseted (Chatsworth PN: 11592-701) and mounted to the concrete slab with four half-inch or greater anchors of the appropriate type. Each rack shall also be braced laterally from overhead or to a structural wall via the use of a universal bracing kit (Chatsworth PN: 10562-001) or equivalent. This bracing shall be installed in a way that does not interfere with accessibility or installation of equipment in the open frame rack.
- F. All rack(s) and associated equipment shall be grounded and bonded to the TMGB or TGB.

OIRM Standardized Device Racking Specifications for Sabey Data Center

**Two-Post 19" Universal rack
(MDF / IDF)
(To be provided by contractor)**

Part No: PRD6 / PRD8 / PRD10 / PRD12
/ PRD15

CHATSWORTH Universal Rack

Size: 19"W x 7' H x 3" D
Color: Black
RMU: 45
Posts: 2 with two top angles
UL Listed
Part No: 48353-703

Mounting Screws

Size: 12-24
Zinc Plated
Quantity: 50
Combination Pan Head
Pilot Point
Part No: 40606-001

Rack base dust cover

Size: 19" W
Color: Black
Channel size: 3"
Part No. 41050-719

Cable Management:

Rack Top Mount Cable Trough

Size: 6" W x 2.25" L
Color: Black
Part No: 12382-719

Large Horizontal Ring Panel

Size: 19" W x 3.47" H x 6" D
Color: Black
Part No: 11564-719

Vertical Cable Management

Brand: PANDUIT
Part No: PRV6 / PRV8 / PRV10 /
PRV12 / PRV15

Vertical Cable Management Doors

Brand: PANDUIT

Accessories:

Small Peripheral Shelf

Size: 19"W x 3.44" H x 10" D
Color: Black
Non-vented
Single sided
Part No: 10758-701

Heavy Duty Equipment Shelf

Size: 19" W x 7.16" H x 20" D
Color: Black
Non-vented
Double-Sided
Part No: 11164-719

Double-Sided Shelf

Size: 19" W x 6.13" H x 21.75" D
Color: Black
Non-vented
Double-sided
Part No: 40108-719

Concrete Floor Installation Kit

Part No. 40604-003

Rack Seismic Gusset Kit

Color: Black
Part No. 11592-701

Universal Earthquake Bracing Kit

Part No. 10562-001

Horizontal Manager Deep 1U 19"

Color: Black
Part No. 30339-719

Horizontal Manager Deep 2U 19"

Color: Black
Part No. 30330-719

General Guidelines for 28" and 32" Wide Cabinet Systems

- A. Equip each cabinet with horizontal cable management channels, grounding lug and two surge protected power strips with IEC-C13 receptacles fed from diverse 208v 30A or 208v 30A 3-phase sources.
- B. Cabinets shall be laid out in a way that allows a minimum of forty-eight inches (48") of clear space in front and thirty-six inches (36") in the rear.
- C. All cabinets shall be equipped with the appropriate air-dam kit and blanking panels for airflow mitigation.
- D. Cabinets shall be equipped with seismic bracing. Each cabinet base shall have the leveling feet removed (if so equipped) and be anchored to the concrete slab with four 5/8", or greater, anchors of the appropriate type. This bracing shall be installed in a way that does not interfere with accessibility or installation of equipment in the open frame rack.
- E. All rack(s) and associated equipment shall be grounded and bonded to the TMGB or TGB.

OIRM Standardized Device Racking Specifications for Sabey Data Center

**28" (700mm) Wide Cabinet System
(Server Cabinets)
(To be provided by contractor)**

CHATSWORTH TERAFRAME

Size: 27.6" W x 83.5" H x 51.00" D

Color: Black

RMU: 45

Square Punched Rails

Perforated Metal Front Door

Perforated Metal Rear Door (When required)

Part No.: 34501-C17)

Two Point Swing Handle Latch

Network Top Panel

2 Solid Sides

Part No: FF2U-110C-C22

Multi-Mount Hardware Kit

Size: M-6

Color: Gold over Zinc

Quantity: 25

Part No: 12637-001

Air Dam Kit

Size: 31.5" W x 45U H

Color: Black

Part No: 34522-C05

OIRM Standardized Device Racking Specifications for Sabey Data Center

**32" (800mm) Wide Cabinet System
("ZERO"/Network Cabinet)
(To be provided by contractor)**

CHATSWORTH TERAFRAME

Size: 31.5" W x 83.5" H x 51.0" D

Color: Black

RMU: 45

Square Punched Rails

Perforated Metal Front Door

Perforated Metal Rear Door (When required

Part No.: 34501-C29)

Two Point Swing Handle Latch

Network Top Panel

2 Solid Sides

Part No: FF3U-110C-C22

Multi-Mount Hardware Kit

Size: M-6

Color: Gold over Zinc

Quantity: 25

Part No: 12637-001

Air Dam Kit

Size: 31.5" W x 45U H

Color: Black

Part No: 34523-C05

OIRM Standardized Device Racking Specifications for Sabey Data Center

**TeraFrame Accessories (for both 28"
and 32" cabinets)**

Cable Management:

Large Horizontal Ring Panel

Size: 19" W x 3.47" H x 6" D

Color: Black

Part No: 11564-719

Horizontal Manager Deep 1U 19"

Color: Black

Part No. 30339-719

Accessories:

MegaFrame Fixed Shelf

Size: 19" W x 3.5" H x 29" D

Color: Black

Single Sided

Non-Vented

Part No: 14070-719

OIRM Standardized Device Racking Specifications for Sabey Data Center

**Cabinet Airflow Management
(To be provided by contractor)**

KoldLok Raised Floor Grommets:

Integral Raised Floor Grommet Item no. 1010

Split Integral – Item no. 3030

Surface Mount – Item no. 2020/30/40

3" Extended – Item no. 10012

6" Extended – Item no. 10013

HotLok Blanking Panels:

1U, 9.5mm square – Item No. 10015 (10)

1U, 9.5mm square – Item No. 10014 (120)

2U, 9.5mm square – Item No. 10023 (10)

2U, 9.5mm square – Item No. 10024 (120)

Plenafill Blanking Panels:

PF-27U-10 10-pack 27U Blanking Panel

PF-GR Green Snap Rivets for Square hole rails

**Note: Make sure to include air dam kits for
Chatsworth Cabinets!**

OIRM Standardized Device Racking Specifications for Sabey Data Center

Power Distribution (To be provided by contractor)

Raritan

DPCS20-30L

Plug: L5-30

Outlets: 20 5-15

Zero RU

DPCS20A-20L6

Plug: L6-20

Outlets: 20 IEC-320-C13

Zero RU

DPCS20A-30L6

Plug: L6-30

Outlets: 20 IEC-320-C13

Zero RU

Another model to be released in Mid-2008 will be 208v 3-phase, L21-30.
Power distribution design will be approved by OIRM.

OIRM Standardized Device Racking Specifications for Sabey Data Center

IP KVM (To be provided by King County)

Raritan Branded IP KVM Switches

CommandCenter Secure Gateway

Part No: CC-SG-E1

2 RU

Dual Power Supply

Dominion SX Serial Console Server

8 Port

Part No: DSXA-8

16 Port

Part No: DSXA-16

32 Port

Part No: DSXA-32

48 Port

Part No: DSXA-48

Dominion KXII IP KVM Switch

16 Port – 4 Remote Users, 1 Local User

Part No: DKX2-416

32 Port – 4 Remote Users, 1 Local User

Part No: DKX2-432

64 Port – 4 Remote Users, 1 Local User

Part No: DKX2-464

Accessories

D2CIM-USB USB CIM for Virtual media

DCIM-PS2 PS2 CIM

DCIM-SUN SUN CIM

DCIM-USBG2 USB / Sun USB CIM

D2CIM-PWR CIM for remote power management

P2CIM-SER Paragon II / KXII CIM for serial devices

III

cl



King County CIRM

DESCRIPTION	REVISED
LABORATORY	3/1/2004 10:44 AM
LABORATORY CONTROL NO. 4.0	PROJECTED
LABORATORY CONTROL NO. 4.0	3/1/2004 10:44 AM
OWNER	DATE
APPROVED	3/1/2004

Sabey Data Center Architecture

Network Overview - Deployment Plan

Document located in: N:\DATA\AS\Architectures\Sabey Data Center

Server Cabinet
Times 80

Access Layer

40" Cabinet
Times 8
2 Server Racks
Per 40" Cabinet

KC WAN Core

Distribution
Module
2 x 6808

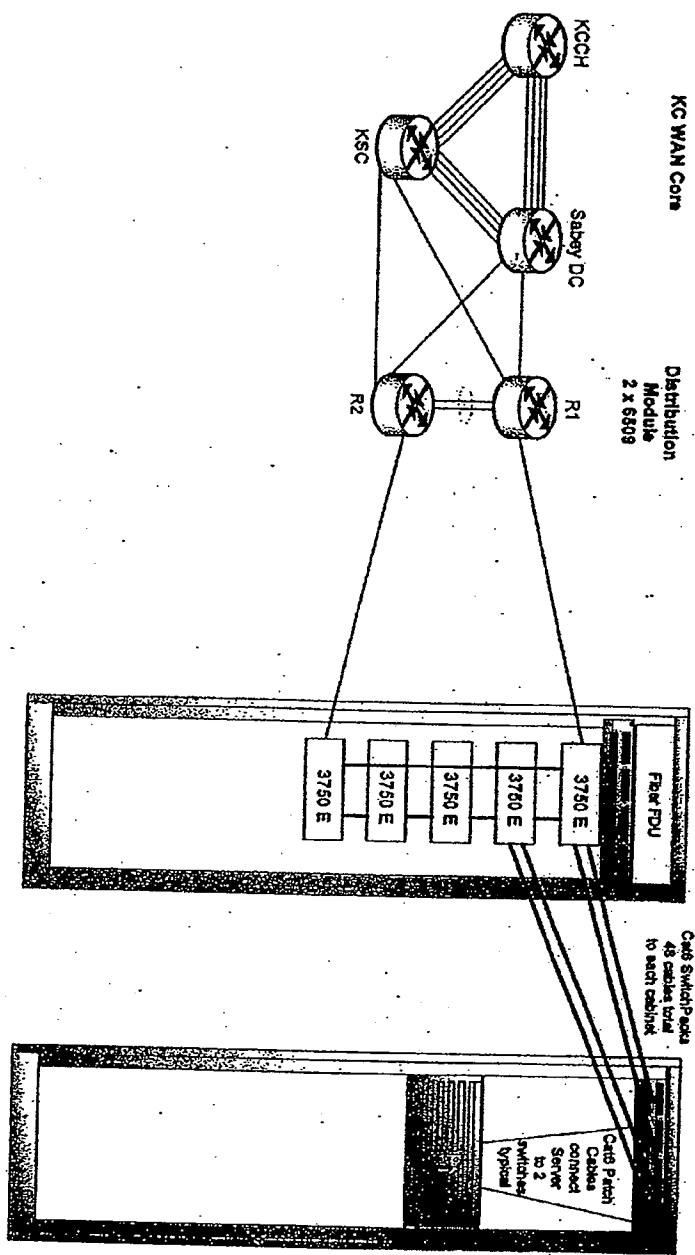

- 10 Gigabit Ethernet 60 Micron MuH Mode
- Gigabit Ethernet MuH Mode
- Gigabit Ethernet Single Mode
- Coax Ethernet Copper
- Bulk Copper Cable

This information is considered confidential/secure information.
 All or part of this document is exempt from disclosure pursuant to RCW 42.56.420 as long as the Washington Public Disclosure Act. It contains information about the operations and activities of the Washington State Department of Transportation's computer and/or information systems. Accordingly, every effort must be made to ensure that this document and the information contained within the document, wherever for public viewing and privacy of the information, should be immediately referred to the Chief Information Security and Privacy Officer and the Risk Policy/Protecting Privacy Officer.



King County ORSM

DESCRIPTION	QUANTITY	REVISION
ONE LINE - SADDLE 1 & 2	1	3/11/2008 3:04 PM
OWNER DATA CENTER	PRINTED	3/11/2008 3:04 PM
CONTRACT NUMBER	DATE	3/11/2008
DESIGNED BY		3/11/2008

96 Cat6 RJ45 Jack to Blunt to be run to 1 Server Cabinet (location TBD) for AVT Servers

96 Cat6 RJ45 Jack to Blunt to be run to 1 MDF Console Management Rack (See MDF Rack Page)

MDF

Document located in: \\KNOX\DATA\AVT\Architecture\Sabey Data Center

Sabey Data Center Architecture

One Line - Deployment Plan

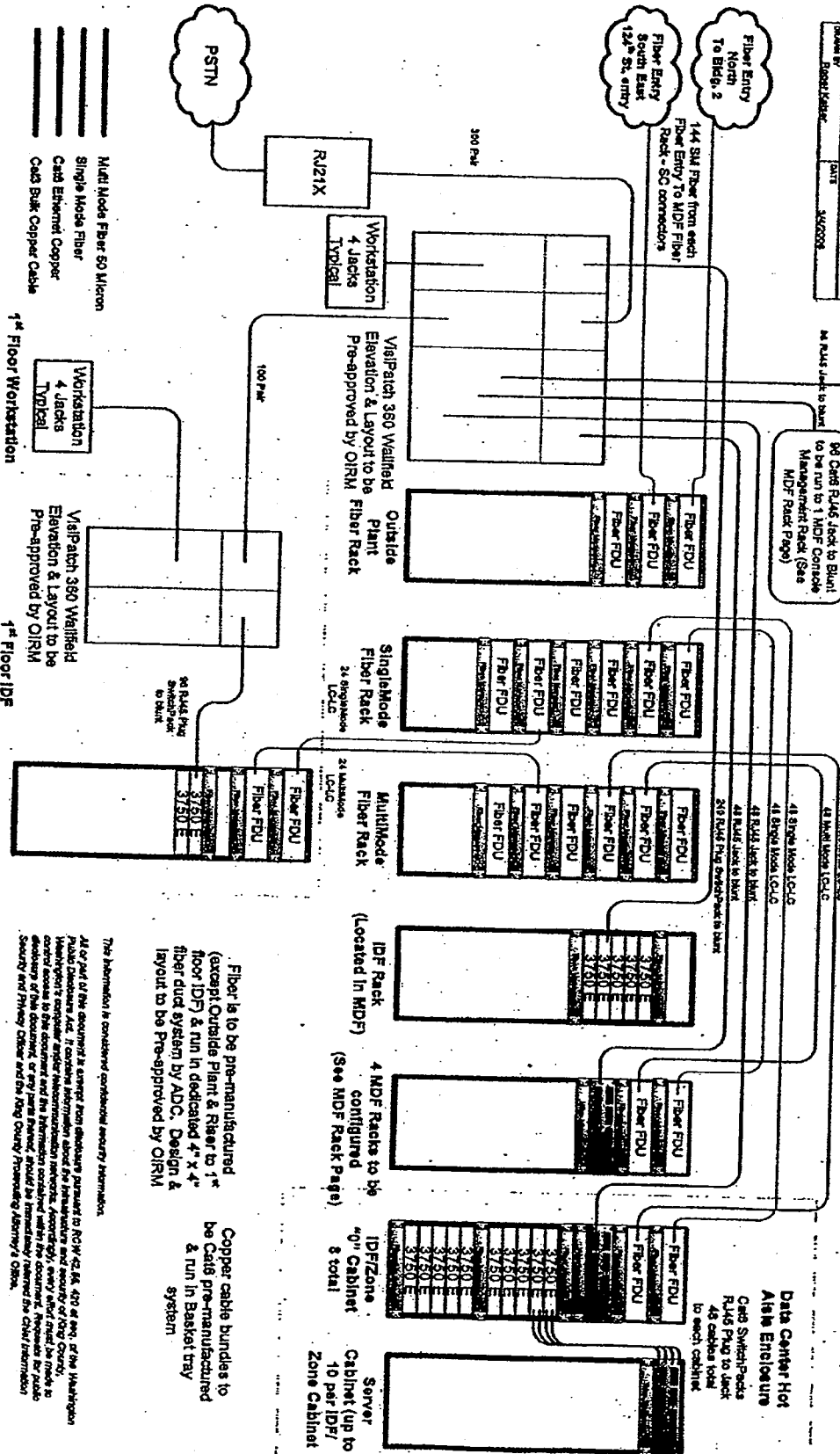

Fiber is to be pre-manufactured (except Outside Plant & Riser to 1st floor IDF) & run in dedicated 4" x 4" fiber duct system by ADC. Design & layout to be Pre-approved by OIRM.

Copper cable bundles to be Cat6 pre-manufactured & run in Basket tray system

This information is considered confidential security information. All or part of this document is exempt from disclosure pursuant to RCW 42.56.420 et seq. of the Washington Public Disclosure Act. It contains information that is exempt from disclosure under the provisions of the Washington Public Disclosure Act, or any laws passed, should be immediately returned to the Chief Information Security and Privacy Officer and the King County Procurement Agency's Office.

- Multi Mode Fiber 50 Micron
- Single Mode Fiber
- Cat6 Ethernet Copper
- Cat6 Back Copper Cable

Workstation
4 Jacks
Typical

Workstation
4 Jacks
Typical

Workstation
4 Jacks
Typical

Workstation
4 Jacks
Typical

Workstation
4 Jacks
Typical

Workstation
4 Jacks
Typical



King County ORNL

DATE/TIME	REVISED	2/18/2008 3:04 PM
BY	PROJECT	2/18/2008 3:04 PM
DESCRIPTION	DATE	3/2/2008
ROOM NAME		

Front of Rack showing

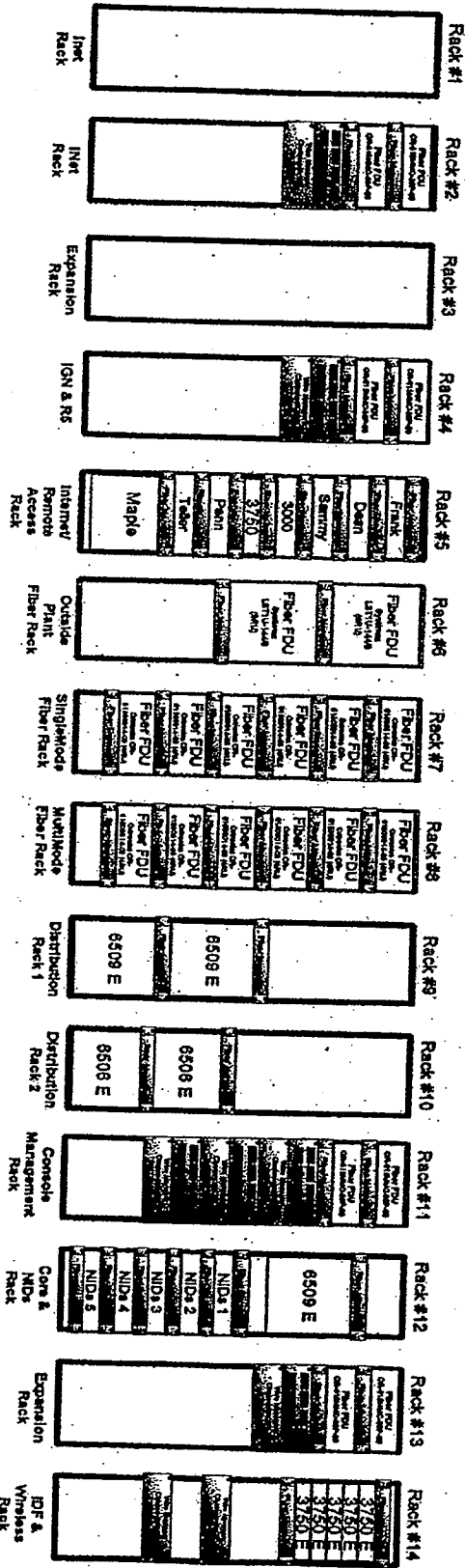

VADP rack 360 Westfield
Elevation & Layout to be
Pre-approved by CIRRM

Fiber is to be pre-manufactured w/
10' service loop (except Outside
Plant & Riser to 1st floor IDF) & run
in dedicated 4" x 4" fiber duct
system by ADG. Design & layout to
be Pre-approved by CIRRM

- Multi Mode Fiber 50 Micron
- Single Mode Fiber
- Cats Ethernet Copper
- Cats Bulk Copper Cable

Fiber Distribution Units are to be:
(2) Systemax LST1U-14/9 (8RU) for Racks #7 & #8
(6) Ortronics OR-81500014-00 (4RU) for Racks #7 & #8
(2) Ortronics OR-81500014-00 (2RU) for
Racks #2, #4, #11 & #13

Fiber Managers are to be
Chatsworth 1RU
Pn 30339-719

Copper cable bundles to
be Cat6 pre-manufactured
by Caryle & run in Beaker
tray system

Panduit PRV12 Vertical
Wire Managers w/Front &
Rear doors shall be
installed between each
rack & at each end

This information is considered confidential security information.
At or part of this document is exempt from disclosure pursuant to RCW 42.56, 42.59 or the Washington
Public Disclosure Act. If possible, information should be redacted from this document. Requests for public
access to this document and the information contained herein should be directed to the King County
Records Management Department, 4000 University Street, Everett, WA 98203, or by email to
records@kingcounty.gov. For more information, please contact the Records Management Department.
Requester's Name: _____
Requester's Title: _____
Requester's Organization: _____
Requester's Address: _____
Requester's Phone: _____
Requester's Email: _____
Requester's Signature: _____
Requester's Date: _____

Sabey Data Center Architecture

MDF Rack Assignment - Deployment Plan

Document located in: \\N:\DATA\BANK\A\Architecture\Sabey Data Center



King County

Always at your service

at

intergate.east
A TECHNOLOGY CAMPUS

**King County Data Center
at
Sabey Data Center 52**

Table of Contents

I. Basis of Design Overview	Pg 1
II. Architectural Overview – Specific to King County	Pg 4
III. Interior Program Summary: Net Areas by Function	Pg 7
IV. Fire Protection Systems	Pg 8
V. Interior Construction and Finishes	Pg 8
VI. Security / Access Systems Provided	Pg 9
VII. Mechanical Overview	Pg 9
VIII. Electrical	Pg 17
IX. Communications and Racks	Pg 22
X. SDC 52 Peer Review RFP	Pg 30
XI. Project Team	Pg 31
XII. Sabey Corporation Overview	Pg 31

SABEY CORPORATION | 12201 Tukwila International Boulevard, 4th Floor | Seattle, WA 98168-5121 |
t: 206.281.8700 | f: 206.282.9951 | www.sabey.com



intergate.east A TECHNOLOGY CAMPUS

Sabey DataCenter 52 (SDC 52)

Basis of Design

-Revisions Specific to King County Data Center-

I. Basis of Design Overview

Sabey DataCenter is developing a data center in an existing building in Tukwila, Washington. The new data center facility is called SDC 52. The building is International Gateway East, Building 5, 3355 South 120th Place, Seattle, WA 98168 also known as SDC 5.

SDC 52 will be a multi-tenant facility and will have 30,000 square feet of IT equipment space supporting an ultimate 4.5 MW of IT load. There will be three tenant modules – each with approximately 10,000 square feet and up to 1.5 MW of IT load. King County Data Center requirement is 1.05MW.

Tenant requirements may vary somewhat, but the base infrastructure (generators, chillers, etc.) will be designed to support the stated objective.

The facility has the ability to be built in three phases for the three tenants; Suite 5201, Suite 5202, and Suite 5203.

Phasing Philosophy

To maintain budgetary controls we will defer additional suite costs until an additional Tenant requirement justifies the build-out without sacrificing redundancy. Design and Construction will take into account that the existing data center can not be impacted during construction of later phases. Overall project cost is also important. The developer, Sabey Data Center LLC understands that there will be some cost impact as a result of extra mobilizations and decreased efficiency. The design will minimize increased costs by (1) envisioning what the later work will require and (2) incurring costs in the earlier phases where appropriate to minimize impact on overall project cost.

System design redundancy objective is according to the industry standard set by the Uptime Institute of Tier 3- Concurrently Maintainable;

IT equipment will be located on the 2nd floor. Generator and UPS modules will be on the 1st floor. Mechanical air handlers utilizing energy saving airside economizer with evaporative cooling may be placed internally on the third floor within one floor of SDC52. Air-cooled chillers will be on the roof.

Electrical

Electrical topology is distributed redundant with major equipment as follows:

Equipment	Phase 1	Phase 2	Phase 3	Total
2.5 MW Generators	2	1	1	4
3000 kVA Transformers	2	1	1	4
UPS Modules	4	4	4	12
STS/PDU's	12	12	12	36

Each Phase has a UPS Group, with a 4-to-make-3 design – if any UPS is taken off line, its load fails to the other three UPS modules, via STS. The STS/PDU's are paired for A and B sources to servers. Dual cord failover occurs without increasing the load on a specific UPS pair. Successful operations require strict management of load to ensure it does not exceed pre-determined limits.

For example, UPS Group 1 consists of UPS A1, UPS B1, UPS C1, and UPS D1.

These UPS modules feed 12 STS/PDU's – AB1, BA1, AC1, CA1, AD1, DA1, BC1, CB1, BD1, DB1, CD1 and DC1. STS AB1 is fed from UPS A1 and B1, with UPS A1 as its primary source. STS BA1 is fed from UPS A1 and B1, with UPS B1 as its primary source.

Dual cording occurs between STS/PDU pairs. AB1 is paired with BA1, AC1 is paired with CA1, and so forth.

Mechanical

Mechanical scheme is air-cooled chillers and air-handlers, utilizing air-side economizer. Major equipment as follows:

Equipment	Phase 1	Phase 2	Phase 3	Total
Air Cooled Chillers	4	2	2	8
Chilled water pumps	2	1	1	4
Air Handlers	2	1	1	4

Mechanical equipment will be aligned with the electrical topology, so that it also has a 4-to-make-3 concept. Failure of any single electrical or mechanical component should not cause an unacceptable impact on the IT equipment or its environment.

Where 4-to-make-3 is not optimal (e.g. fuel pumps), it is permissible to arrange mechanical equipment in a 2-to-make-1 or 3-to-make-2 concept, so long as redundancy is maintained. Utilizing an ATS to

maintain redundancy is also a possibility. No single electrical failure should cause a data center failure – on any system.

II. Architectural Overview – Specific to King County

Data Center Area – 2nd Floor

Data Center Module: 7492sf. With an additional 3834sf of expansion space

Racks will be installed on the concrete slab on grade and will not require an access floor system.

The server area will be electrically supported by a dual overhead busway system. The busways will be fully supported by UPS and generator.

Floor loading is 125lbs/sf.

Communications cabling will be distributed by an overhead cable tray system.

All racks will be configured in the ASHRAE TC9.9 “Hot Aisle/Cold Aisle” arrangement. A hot aisle containment system will be used to isolate cool supply air from the hot return air. The containment system will be installed above the racks to the ceiling grid and will be composed of metal channel framing and insulated sheet metal panels. The ceiling tiles will be removed over the hot aisle between the rack rows.

Supply air will be flooded into the space from the third floor air handling units and will flow along the cold aisles to the faces of the server racks. Hot return air will be rejected into the hot aisle, where it will flow upwards to the ceiling return air plenum back to the air handling units. It will be important to install blanking plates in any unoccupied rack units for the containment system to function properly. The module will be separated from other suites by 1-hour fire resistive construction

Expansion Space

There will be an additional 3834sf of additional space to the north of the existing data center module. These two areas will be separated by a 1-hour fire resistive construction wall. This space will require additional installation of overhead duct work, racks, separation panels, electrical busway and cable tray prior to implementation.

MPOE (Main Point of Entry) Two building MPOE Rooms will be support telecommunications access to the modules and provide for the entrance of telecommunications conduit from the site communications vaults. MPOE Rooms will not house any active electronic equipment and will be used for transit of communications cable only. These are restricted areas and are located at opposite sides of the building. The North MPOE will be located within the Suite 5201 Expansion Space and will need to be accessible by approved Building personnel.

Each SDC 52 module will receive one 4” dedicated conduits from each of two diverse MPOE rooms. The MPOE rooms are considered as building common space and will only be accessible to persons approved by building management, in accordance with security protocols.

MDF Cage: Approx 200 sf

The MDF cage will provide for 12 telecommunications racks and will be located on the east perimeter wall in the Data Center area. All active carrier and King County backbone communications equipment will be housed in this cage.

One each 4" communications conduit will be installed from each of the MPOE Rooms via overhead routing to the MDF Cage.

Power and cabling distribution inside the MDF will be by an overhead system similar to the Data Center area.

The MDF Room must be supported on UPS and generator and will share the Data Center cooling system.

The MDF Room will be separated from the Data Center with Cage material, height to be determined and will be open on the top. A slider door will provide egress.

The back wall or exterior wall will be covered with vertical hung 4x8' fire-rated plywood. Fire rating stamp not to be painted.

Entry Vestibule: Approx 200 sf

Access to the Data Center is via a double door entry vestibule. Access to rooms outside of the Data Center are via the secure exterior door. Entrance into the Data Center area is via a second secure door.

Network Operations Center: Approx 700 sf

The Operations Center will support Network Operations & Engineering staff, including monitoring stations for network operations. Networking staff will be located in standard workstations.

The Operations Center is located to be able to monitor personnel entering Data Center area, provide close access to Print Room, easy access to Data Center, visibility through windows into the Data Center area where Tapes and Mainframe equipment are located.

The module will be separated from other areas by 1-hour fire resistive construction

Secure Storage/ Server Build Room: approx 250sf

The Secure Storage/ Server Build Room will provide a room to uncrate equipment, provide short term storage area and do initial burn-in tests on new equipment. This room will be outside of the Data Center envelope to reduce cardboard contamination of the Data Center. Access to this room is outside of the Data Center.

The module will be separated from other areas by 1-hour fire resistive construction

Print Room: approx 1300sf

The Print Room will provide a dedicated room to house King County printers for specific applications. This room will be outside of the Data Center envelope to reduce paper contamination of the Data Center. Delivery of paper to this room is via a door to the common access corridor. An interior door allows access to the Entry Vestibule.

The module will be separated from other areas by 1-hour fire resistive construction.

Restroom Facilities:

The Data Center common area restrooms are located off the 2nd floor Elevator Lobby approximately 100 feet away from Data Center Entry Vestibule. Both Men's and Women's bathrooms are available and both are ADA compliant

Office & Storage Area – 1st Floor

Office Area – 4078sf

The Office Area will include: 30 work stations comprising the following; Managers- 4, Production Support- 9, Call Center-6, Production Engineering- 8, Production- 3, an Incidence Response/Conference Room, Manager/Conference Room, Break Room and an IDF room.

Restroom Facilities: Common

The Office Area common area restrooms are located approximately 30 feet outside the Office Area entrance. Both Men's and Women's bathrooms are available and both are ADA compliant.

Kitchen Area & Break Room: Common

The Kitchen Area is a common area with countertop, sink, refrigerator and overhead cabinets. It is within 30 feet of the main entrance of the Office Area. Vending machines, a microwave and tables with chairs are currently installed.

Storage Area: approx- 750sf

A dedicated, secure storage area for paper storage is located on the first floor. The storage area is adjacent to a roll-up door for ease of deliveries.

Entry to the Building:

The primary entrance to the building is in the SE corner of the building. This entry is a ballistics grade lobby and entry to the building is limited to the entrance lobby without a security card. Secure entry to the building is via maintrap entries. All doors beyond the entry lobby require a security card.

A secure area for up to 2 security officers to visually monitor access to secure areas and receive visitors is provided. A visitor counter includes a glass security screen with a pass through and intercom.

The area includes video security monitors, key station and other security related equipment. Security officers are also responsible for issuing building access badges.

Security officers have unrestricted visual access to all areas of the Lobby and the Security Vestibule.

This entry is unlocked during normal business hours. After normal business hours a key card is required. This entrance has a security officer posted during normal business hours. Off hours, the security officer may be at the Entrance facility or on rounds.

Loading Dock and Shipping/Receiving Areas: Common

A secure Loading Dock Area is directly accessible from the exterior and incorporates two "dock levelers" inside of two electric roll-up doors. Access to the Shipping/Receiving Area is restricted when the either or both of the Loading doors are open. The Shipping/Receiving Area is directly connected to the Loading dock and provides a larger area for processing shipments, repackaging or uncrating shipments

Utility Areas – 1st Floor

Building Switch Gear Room: Restricted

The Building Main Switch Gear Room houses the primary service entrance switch gear from the utility.

The room is located along the perimeter of the building for access of feeders from the site distribution stations.

Generator Room: Restricted

As previously described, SDC 52 will be a multi-Tenant, "shared infrastructure" environment. The generating capacity for all three modules will be collocated within the Generator Room. The Generator Room will house up to 4 – 2,500 kw standby diesel generators and will include multiple day tanks for the generators in this room. Unit substations will also be housed in the Generator Room. The Generator Room will be separated from other areas by 1-hour fire resistive construction.

UPS Electrical Room: Restricted

As previously described, SDC 52 will be a multi-Tenant, "shared infrastructure" environment. The UPS capacity for all three modules will be collocated within the UPS Electrical Room. The UPS Electrical Room will house both the "Normal" electrical distribution equipment and the UPS system for the "Critical" distribution equipment for the Data Center Module and certain loads in the Office Area.

The room will be required to be 1-hour fire resistive construction.

Sprinkler Valve Room: Restricted

Multiple Sprinkler Valve Rooms house the incoming fire service and pre-action valves for the building. The pre-action sprinkler valves for the King County spaces are located in a room directly adjacent to the Generator Room. It has a secure exterior entrance for fire department access as well as authorized maintenance and security staff.

III. Interior Program Summary: Net Areas by Function**King County Office & Data Center Room Comparison**

Room	Sabey	Criteria
Data Center	7492	6383
Data Center Expansion	3834	
UPS	NA	295
MDF	~200	350
Command Center/NOC	~700	648
Printer Room/Paper storage	1318	1240
Server Build Room	250	n/a
Incident Response	In General Office	250
Break Room	In General Office	240
General Office	4078	2712
Dedicated Paper Storage	750	600

Tape Storage	In Data Center area	350
Managers Conf Room	In General Office	n/a

IV. Fire Protection Systems

The building is fully protected equipped with an automatic fire sprinkler system. Three primary types of sprinkler systems are used: Wet pipe sprinkler systems are installed in two corridors. Dry sprinkler pipes are installed in the open air alley areas on the first floor and double interlocked pre-action sprinkler systems are installed for the balance of the building

Fire extinguishers in office areas, corridors, and data halls are housed in semi-recessed cabinets. Fire extinguishers in electrical and mechanical spaces are installed on wall mounted brackets.

VESDA System

A VESDA or Very Early Smoke Detection Alarm system or similar incipient smoke detection system will be installed in SDC5201 and is planned for all three SDC52 modules. Each module will be separately monitored.

VESDA™ is a brand of air-sampling smoke detector which is capable of detecting the microscopic particles of smoke. Most of the detectors in the VESDA™ range are aspirating smoke detectors. Generally, aspirating smoke detectors, which are 'active' in nature vs. conventional detectors which are 'passive' in nature, work by drawing air in through a network of small-bore pipes laid out above or below a ceiling in parallel runs covering a protected area. Small holes are drilled into each pipe to form a matrix of holes (sampling points), providing an even distribution across the pipe network. The air sample is drawn past a sensitive optical device (in the case of most VESDA™ detectors a robust solid state laser) tuned to detect the extremely small particles of combustion. A VESDA™ detector may be used to trigger automatic fire responses in high value, or mission critical areas such as archives or computer server rooms.

VESDA™ and similar smoke detection systems (HSSD's or High Sensitivity Smoke Detectors) provide multiple levels of alarm threshold such as: Alert, Action, Fire 1 and Fire 2. Thresholds may be set at levels across a very wide range of smoke levels. This allows the earliest possible notification of a developing fire allowing intervention before a fire develops beyond the smoldering stage - allowing increased time for evacuation, or the implementation of Emergency Response or Business Continuity Plans. Fire thresholds may be used to notify local or municipal emergency responders and ultimately to discharge fire suppression systems.

The environmental sensitivity for VESDA™ and other HSSD's are well known for their ability to not commonly cause false alarms, however VESDA and similar smoke detectors can be adjusted to accommodate temporary changes to alarm thresholds in non-emergency conditions. Alternatively VESDA™ detectors offer a referencing capability where a reference detector allows the influence of widespread smoke to be eliminated while maintaining absolute sensitivity in the areas where it is required.

VESDA™ is owned and operated by Xtralis, formerly known as Vision Fire & Security of Melbourne, Australia. www.vesda.com

V. Interior Construction and Finishes

Interior Finishes by Functional Area and Room

Room or Area	Flooring	Walls	Ceiling
Data Center Area	VCT w/non-static wax	Painted GWB	2' x 2' ACT

Office Area	Existing building carpet	Painted GWB	4' x 2' ACT
Storage Area	Sealed concrete	Painted GWB	Open to deck above

VI. Security / Access Systems Provided
by Functional Area and Room

Room or Area	Access Control	Cameras
Data Center Area	Exterior doors only	Exterior doors only
Office Area	Exterior door only	Common hallway only
Storage Area	Exterior door only	None

VII. Mechanical Overview

**HVAC Advantages and Features
of SDC52**

Choice of Economizer Mode vs. Critical Mode is determined by Building Automation System:

The third floor cooling and ventilating (HVAC) equipment installed for King County can function in parallel with other equipment serving the neighboring SDC52 Tenant spaces to reliably and efficiently meet each tenant's individual temperature and humidity requirements (within a broadly anticipated range - see "Criteria Summary" below - or otherwise as negotiated with other tenants). When "all systems are go" (no smoke alarms, equipment failures, maintenance shutdowns nor poor outdoor air quality), the building control system will operate the air handlers in the "Economizer" Mode described below. Upon equipment failure, maintenance shutdown, detection of poor air quality or certain types of smoke detection, the building control system will operate the air handlers in the "Critical Mode" described below. Each individual tenant's space conditions (temperature, humidity, airflow and room pressurization) will be unaffected by this change in the HVAC System Mode.

Tenant HVAC Systems can operate Separately or Combined:

The selection of four air handlers' groupings to serve three individual tenants through three sets of supply and return shafts is intended to reliably provide "Critical Mode" cooling to each tenant despite a variety of foreseeable disruptions including smoke detection in the tenant's own space, smoke detection in a neighbor's space, or smoke detected in an individual air handler. Deliberate design decisions were made to comply with exceptions Building Code and Mechanical Code provisions that would otherwise require automatic (smoke) shutoffs and dampers in positions that might create "single points of failure". See diagram 1 on sheet M-1, the "HVAC Schematic Diagram", where the system separation dampers are indicated by name, and see the scenario chart on this page which lists the foreseeable disruptive events along with the automatic (Building Control System) response. Each of these foreseeable scenarios results in a continuation of cooling to each tenant.

Power to the HVAC system comes through at least two electrical power distribution busses. Eventually there will be four distribution busses serving the tenant network on the 2nd floor north. HVAC system

fans and refrigeration equipment will be equally loaded onto each distribution buss. To meet the landlord's 150W/ft² criteria and provide redundancy, enough cooling for 1.5 megawatts of critical load may eventually be placed on each distribution buss, to provide power and cooling to the tenants even when one buss is taken out of operation. Since 480V double-conversion UPS systems are expected to back up all critical loads, the transformer and UPS heat rejection will bring the cooling load to 1.65 megawatts of heat removal capacity per buss. The electrical energy component of operating costs does favor the partially loaded scenario so there is no burden on the tenant even though King County's total heat removal requirement is expected to be less than 1.2 megawatt.

Energy Efficient operation with Improved Reliability:

Equipment heat is removed from this tenant's space using two methods. A separated hot aisle enclosure will surround the initial arrangement of cabinets, ensuring no hot spots occur while allowing very high wattage servers to be placed wherever desired in the cabinets without need for air balancing adjustments. To achieve these goals, it will be necessary for the operators to place readily available "blanking plates" between servers within the cabinets to maintain the separation barrier between hot and cold sides. Heat-producing equipment that isn't cabinet-mounted (such as the floor-mounted printers and legacy mainframe computers) will be located in a designated area of the room where the second heat removal method (dilution with cold air from adjustable overhead ductwork) has been provided. There are two modes of operation of the tenants' HVAC system, a reliable "critical" chilled water cooled mode (using no outside air) and an ultra efficient "economizer" mode (using outside air).

The system routinely operates in the economizer mode but whenever poor outdoor air quality occurs, or a loss of utility water pressure, or a necessary maintenance shutdown, or an equipment failure; in which case the transition to the critical mode will be automatic and alarmed. Both HVAC operating modes use variable air volume (VAV) control to save energy, meaning the room's supply air temperature and humidity remain constant and while the quantity of air moving through the tenant space varies in order to remove the heat being produced by the equipment at that time. It is up to the tenant to operate at least 10 kW of equipment in order to provide some heat, the desired temperature and humidity cannot be maintained in spaces that do not require cooling.

Criteria Summary:

TENANT'S SPACE CONDITIONS:

entering computers: 66°±2°F (however, higher energy savings are available @ 72 ±) with 45±10% relative humidity.

in printer room: 72°F with 40±10% relative humidity (including space for open paper packages)

in paper storage 72°F with no humidity control (paper will be kept in shipping wrappers)

UPS/battery room maintained within manufacturer's recommended temperature and humidity.

INFORMATION TAKEN FROM SUBMITTALS:

Xerox 4110ST Printer heat output: 3100W (10,580 Btuh) with accessories

Xerox HLC128: 35,850 Btuh (operating) recommended 74°±4°F with 50±15% r.h.

MGE 500kva UPS module: 4070 cfm exhaust & 110,750 Btuh each, recommended 32°F to 104°F with 0-90% rh.

HVAC LOAD CALCULATION BY ROOM:

Printer room equipment total 46.5 Mbh, Lights 1.5 Mbh, People 1 Mbh. Total peak 50 Mbh to be met with up to 2700 cfm of 55°F air. At owner's requested condition (supply air cooled to 51°F for dehumidification), only 2300 cfm peak is required.

NOC room load is unspecified. 2.5 cfm/ft² or 2000 cfm will be provided. With supply air cooled to 51°F for dehumidification, that will remove 15 kW from the room if the temperature setpoint is 75°F. Office space on 1st floor is provided with 0.75 cfm/ft² to account for 1W/ft² lights, 2W/ft² equipment, and 35 people/4000ft².

Tukwila water-cooled CHW plant
Serving 1.09 Megawatt Tenant
Mechanical System Options
11/2/07 7:47 AM

Using Seattle Weather Data
 Using SCL MDS suburban rates;
 basically \$4/kWhr
 with (average) \$11kW demand
 charge,
 water \$10 per CCF Incl. Sewer

Jeff Sloan, McKinstry Co.
 jeff@mcKinstry.com

Key Variables

First cost factors - Mechanical contractor

Critical refrigeration tonnage	353 tons
Airflow quantity, fully populated	256,000 cfm
Peak (not dry) city water draw	13 gpm
Tank that would be required for 24 hours water storage	19,700 gallons
Thermal storage tank volume to allow chillers to restart	14,117 gallons
First cost factors - Electrical Contractor	
HVAC load on generator, Utility distribution	505 kW
Number of 3a Components to Connect	
First cost factors - General Contractor	
Indoor HVAC Equipment space	
Need for access floor, suspended ceiling	Both recommended
HVAC space on roof	Cooling towers
Cooling towers	\$667,662
Total Annual Operating Cost:	
Computers, UPS, and Transformer Electrical Cost:	\$494,802
HVAC Electrical Cost:	\$159,180
HVAC Water Cost:	\$14,800
Maintenance Cost:	

Method for avoiding hot spots:	frequent adjustments of floor & RA dampers
Hours out of a typical year system can operate without chillers:	0 hours

Base	Option A	Option B	Option C
Chilled Water CRAC units with no Economizer whatsoever	Chilled Water CRAC Units with Water Economizer, Steam Humidifier	Chilled Water CRAC Units with Air Economizer, Steam Humidifier	Chilled Water Air Handlers with Evaporative Air Economizer
Open Hot-Cold Aisles	Open Hot-Cold Aisles	Open Hot-Cold Aisles	Separated Hot-Cold Aisles
353 tons	353 tons	354 tons	328 tons
256,000 cfm	256,000 cfm	256,000 cfm	197,148 cfm
13 gpm	13 gpm	13 gpm	11 gpm
19,700 gallons	19,700 gallons	20,400 gallons	15,500 gallons
14,117 gallons	14,117 gallons	14,548 gallons	13,188 gallons
505 kW	517 kW	553 kW	398 kW
Both recommended	Both recommended	Both recommended	Neither recommended
Cooling towers	Cooling towers	Cooling towers	CHW airhandlers, lowers
\$667,662	\$474,616	\$664,968	\$559,797
\$494,802	\$494,802	\$145,886	\$494,802
\$159,180	\$159,180	\$14,800	\$82,080
\$14,800	\$14,278		\$3,136
frequent adjustments of floor & RA dampers	frequent adjustments of floor & RA dampers	frequent adjustment of floor & RA dampers	all adjusted automatically
0 hours	592 hours	3972 hours	4813 hours

HVAC Options Annual Operating Cost Summary

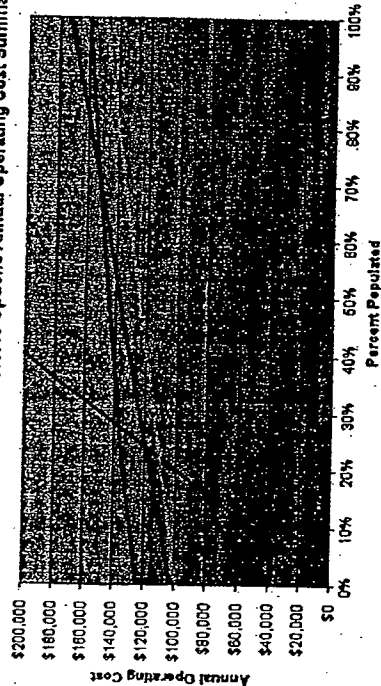

— Servers Themselves

— Chilled Water CRAC units with no Economizer whatsoever, Open Aisles

— Chilled Water CRAC Units with Water Economizer, Steam Humidifier, Open Aisles

— Chilled Water CRAC Units with Air Economizer, Steam Humidifier, Open Aisles

— Chilled Water air handlers with Air Economizer, Evaporative Humidifier and Separated Aisles

McQuisity
 Mechanical & Electrical
 10000 W. 10th Ave.
 Suite 100
 Westminster, CO 80040
 Phone: 303.426.1100
 Fax: 303.426.1101
 Email: info@mcquisity.com

**KING COUNTY
 AT RAYE CORP
 TUX & BUILDING
 SEC 2.01
 TUX, WA 98148**

No. Home: PDF produced by PDSH (3) P. Report - http://www.pds.com/tech/tech.html

Project Name	King County at Raye Corp Tux & Building
Project No.	10000 W. 10th Ave. Suite 100
Client	McQuisity
Design	McQuisity
Drawn	McQuisity
Checked	McQuisity
Scale	AS SHOWN
Date	11/2/2007
Sheet No.	M1.0
Sheet Title	HVAC SYSTEM SCHEMATIC DIAGRAM

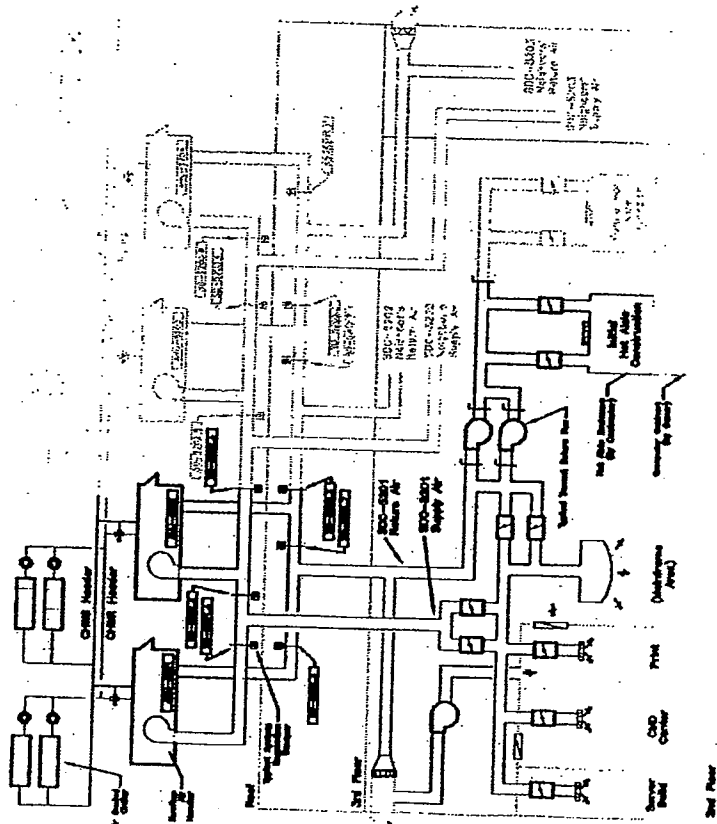

HVAC SYSTEM SCHEMATIC DIAGRAM

F:\M1.0-HVAC Description.dwg, 11/2/2007 7:36:03 AM, JEFFS

Mechanical Scope of Work Break-down

Mechanical work to be performed by the McKinstry Company
Proposed Scope of Work, Updated 2-15-2008

Project Description:

All mechanical systems associated with a fully functional build out for suite 5201 along with piping and ductwork infrastructure as practical to accommodate build-out of suites 5202 and 5203. Additionally, equipment will be included as required for N+1 redundancy for suite 5201.

Basis of Design

Server Room:

Load: Cooling will be provided for a 1.05 MW server load.

Environment: The servers will be supplied with $75^{\circ}\text{F} \pm 2^{\circ}\text{F}$ and a relative humidity of 40% to 70%. Humidity will be provided by evaporative humidifiers located (and designed into) the custom rooftop units.

Redundancy: The system will be designed to Tier 3 Data Center Standards and will be concurrently maintainable.

Air distribution: Conditioned air will be provided by custom chilled water air handling units located on the third floor. The air will be ducted down from the roof, through the third floor, to the second floor for distribution within the server room and ancillary spaces. The servers will be arranged in a hot/cold aisle configuration. The hot aisles will be separated from the conditioned server room area. The heat discharged from the servers into the hot aisle will be collected by return air fans and ducted up to the roof for rejection to the outside.

Printer Room:

The printer room will be conditioned with supply air (ducted down from the third floor units) to the space. A variable air volume (VAV) terminal unit will provide conditioned air as needed to the room (to maintain the rooms temperature set point). Heat from the printers will be collected and ducted up to the return/relief air system.

Office Area:

The office area will be conditioned with supply air (ducted down from the third floor units) to the space. A variable air volume (VAV) terminal unit will provide conditioned air as needed to the room (to maintain the rooms temperature set point).

Note: The above descriptions are a brief narrative. Please refer to schematic diagram of proposed systems for a detailed depiction of the interaction of all systems.

Mechanical Systems Scope of Work:

Generator Room

Area Clarifications:

- Louvers at generator engine radiator cooling intake by others. (Sabey Construction- SCI)
- All fuel pipe trenching (cutting, concrete, etc) by others- SCI. McKinstry will provide the fuel pipe

SABEY CORPORATION | 12201 Tukwila International Boulevard, 4th Floor | Seattle, WA 98168-5121 |
t: 206.281.8700 | f: 206.282.9951 | www.sabey.com

only.

- Fuel pipe is standard schedule 40 screwed pipe. No double containment is included.
- There is leak detection in the fuel trench.
- Fuel pipe point of connection is assumed to be above the slab.
- It is assumed that generator exhaust piping can run up the side of the building.
- Generators are provided and installed by others- SCI
- Day tank is by others. It is assumed that a return pump will be provided with this tank.

Area Scope (by McKinstry):

- Installation of emergency generator mufflers. Mufflers and flex provided by others.
- All required emergency generator exhaust piping (welded and wrapped) from each generator, out the side of the building, up to a height of 12' above roof parapet.
- Fuel supply and return piping from man hole located in the generator room vicinity to day tank (tank by others) and then distributed to each of the emergency generators.
- Fuel vent piping for the day tank.
- Exhaust for generator room / transfer switch area, including associated ductwork, grilles, and fittings.
- Sound traps at generator radiator discharge plenums (approximately 10'x10', total of four).
- Sound trap at room intake opening (approximately 20'x10', total of one).
- Rework and drop sprinkler heads as necessary for fire protection.

Phase Breakdown – it is assumed that two generators will be installed for phase A, one for phase B, and one for phase C, for a total of four.

UPS and Battery Room

Area Scope (by McKinstry):

- Two (2) suspended evaporative cooling units.
- All ductwork, grilles, and fittings.
- Battery room exhaust fans and associated ductwork.
- Fire protection (Preaction with VESDA detection).

Server Room Cooling – Custom Rooftop Units ducted down shafts to the second floor.

Area Clarifications:

- Shafts will be required through the third floor for both supply and return air ducts.
- Units will be located on the 3rd floor. There will be openings required above the units for outside air intake hoods.

Area Scope (by McKinstry)

- Provide and install Two (2) custom chilled water air handler units (115,000 cfm each). 1 unit required to meet load requirements + 1 redundant unit. Includes factory roof curbs, integral relief fans, supply and return air fans, VFD's, filters, 100% outside air economizer, evaporative humidification.
- Provide and install approximately 500 tons of chiller capacity – Multistack modular air cooled chillers located on third floor.
- Chilled water pump skid with pumps, chemical treatment package and all accessories. Sized as necessary for future tenant suites.
- Domestic water piping to each AHU for evaporative humidification (back flow preventer included).

- Chilled water piping as required for a complete and functioning system (insulated as required by code). Piping will run from Chillers to coils located in custom roof top units.

- Fire protection: Preaction with Vesda detection. One preaction zone per suite.

General inclusions:

- Insulation as required by governing Energy Codes.
- Direct digital controls: including graphics, user work station, and programming.
- Variable frequency drives as necessary for supply and relief fans.
- Crane Hoisting (one mobilization per phase).
- Commissioning, testing, adjusting, and balancing.
- Permits and Coordination with local code officials.
- Start-up and functional performance testing of equipment.
- As-built drawings and O&M manuals.
- One year warranty.

Items included in McKinstry scope;

Shell and Core HVAC (Equipment/Duct and piping)

UPS and Battery Rooms

Generator mechanical and fuel piping inside generator room

Tenant Space – Distribution ductwork + hot aisle fans

Tenant Space – Aisle Separation

Scope includes fire protection, VESDA, plumbing, and HVAC for each of the areas broken out above.

Mechanical Engineering and Preconstruction are included.

General Exclusions to be performed by others (Sabey Construction)

- Doors at hot aisle entrances.
- Engineering and CAD services (soft costs)
- Cutting, patching, painting, core drilling, concrete cutting, demolition, and disposal.
- Shafts and shaft walls.
- Structural modifications or engineering.
- Acoustical consultant fees.
- Warranty for existing system components.
- Extra hangers or bracing to the existing systems.
- Electrical work, starters, or disconnects.
- Heat tracing.
- Seismic upgrades to existing systems.
- Performance bond.
- Painting of existing, priming of new, and finish painting of new ductwork or piping.
- Washington State Sales Tax.

VIII. Electrical

Project Description

Provide all electrical line voltage systems for a fully functional build out of Suite 52-01. Provide infrastructure for the future build out of Suites 52-02 and 52-03. This includes main switchgear, generators, transfer switches, unit sub-stations, UPS units, distribution gear, branch circuiting to racks, lighting, cable and fiber tray, and office build out. Provide 1.05 MW of UPS power and distribution for the Server Room area.

Infrastructure

- Provide one 1200A, dual bus, 27 kv switchboard (MSG-2) with tie breaker. The switchboard will have two separate incoming high voltage feeds (Bus #1 and Bus #2). Provide two 1200A frame 27 kv circuit breakers with relay trip on each bus. Provide one spare space for a future circuit breaker on each bus.
- Provide two 3000 kva unit sub-stations. This transforms the power from 26.2 kv to 480 volts. Each to be dual fed by a breaker from each bus on MSG-2.
- Provide two 4000A distribution switchboards (480 volt) for power to the UPS units, lighting and mechanical loads. Provide breaker space to accommodate a 1600A mechanical distribution board, four UPS units, two 50A misc loads and a breaker to feed a factory mounted TVSS unit. Provide dual input feeds with automatic transfer control module. This serves to transfer the load from utility to generator supply.
- Provide two Caterpillar 2500 kw generators (480 volt). Make provision for temporary load bank connection. Provide day tank. Mechanical to provide piping and connections to building fuel storage system.
- Provide four 562 kw (625 kva) UPS units with static and maintenance bypass and 5 minutes of full load battery back-up. Preferred UPS vendors are MGE and Mitsubishi.
- Provide fire alarm per local Code and Sabey Data Center. Provide interface for Vesda controls. Vesda is provided as an alternate.
- Provide perimeter security, access control and video surveillance.

Server Room

- Provide redundant runs of 225A or 400A Starline busway for distribution over the equipment cabinets.
- Provide EPO shut-off as required by Code.
- Mechanical design is based on McKinstry's hot aisle, cold aisle system.
- Provide two circuits to each floor cabinet (quantity to be verified). Each circuit will feed a dedicated L21-30R device and each will be fed from a different source bus.
- Provide fluorescent lighting centered on aisles at 50 fc minimum. Provide zoned switching. Lighting to be direct/indirect where appropriate. Note: If a grid ceiling is installed, we will use 2x4 direct/indirect layin fixtures. Provide power to mainframe area computers.
- Provide power and connections to eight 40 hp w/VFD return air fans.
- Provide cable tray centered above cabinets.
- Provide fiber tray centered above cabinets.
- Provide conduits to Server Room from building MDF.

Printer Room

- Provide UPS power to printers
- Provide lighting at 50 fc minimum and local switching.
- Provide power and data rough-in for counter mounted misc printers and faxes.

Office Area

- Provide UPS power for computers (at least one outlet per cubicle) and normal power for non-critical loads
- Provide lighting at 50 fc minimum and occupancy sensors controls as required by Code.
- Provide data outlets (rough-in only) at all cubicles and workstations.

Generator Room

- Generators to be provided and maintained by Sabey Data Center.
- Units to be 2500 kw (3125 kva) Caterpillar diesel generators with day tank.
- Provide lighting, power and connections consistent with the other generator rooms in the facility.
- Provide monitoring consistent with other facility installations.

Operations and NOC

- Provide UPS power to all equipment.
- Provide lighting at 50 fc minimum with a combination of dimming fixtures and local switching.
- Provide data outlets (rough-in opening only) at all workstation locations.

Switchgear and UPS Room

- Provide two 4000A 480 volt switchboards. Each are to be dual feed with automatic transfer control modules.
- Switchboard to have breakers to feed four UPS units each.
- Provide two 1600A distribution panels for mechanical loads.
- Provide misc transformers and panelboards for lighting and receptacle loads.
- Provide four 562 kw (625 kva) UPS units. These will be 480 volt 3 phase input; 480 volt 3 phase output.
- Battery back up time at full load to be 5 minutes.
- Provide four maintenance bypass panels, one for each UPS.
- Preferred vendors are MGE and Mitsubishi.
- Provide lighting centered between equipment at 30 to 50 fc with local switching.

Roof

- Provide power and connections to two rooftop units.
- Provide power and connections to four chiller units.
- Provide misc power and connections for heat trace (FBO) and circ pumps.

Inclusions

1. Asbuilt drawings and O&M manuals.
2. One year warranty.
3. Permits.
4. Start up and testing.
5. Coordination and cooperation for commissioning.

Exclusions (by SCI)

6. Washington State Sales Tax.
7. Reprographic costs.
8. Cutting, patching, painting, core drilling, concrete cutting, demolition and disposal.
9. Heat tracing except for circuit connections.
10. Structural modifications and engineering.

11. Shafts and shaft walls.
12. Seismic upgrades to existing systems.
13. Performance bond.
14. Engineering and CAD services (soft costs)

Electrical One Line Drawings on following two pages:

NOTES:

TO SITE POWER DISTRIBUTION
 60° 5°C, 3P/3W, 182/0 GROUND, 182/0 NEUTRAL

27KV SWITCHGEAR - MSG-2

TO SITE POWER DISTRIBUTION
 60° 5°C, 3P/3W, 182/0 GROUND, 182/0 NEUTRAL

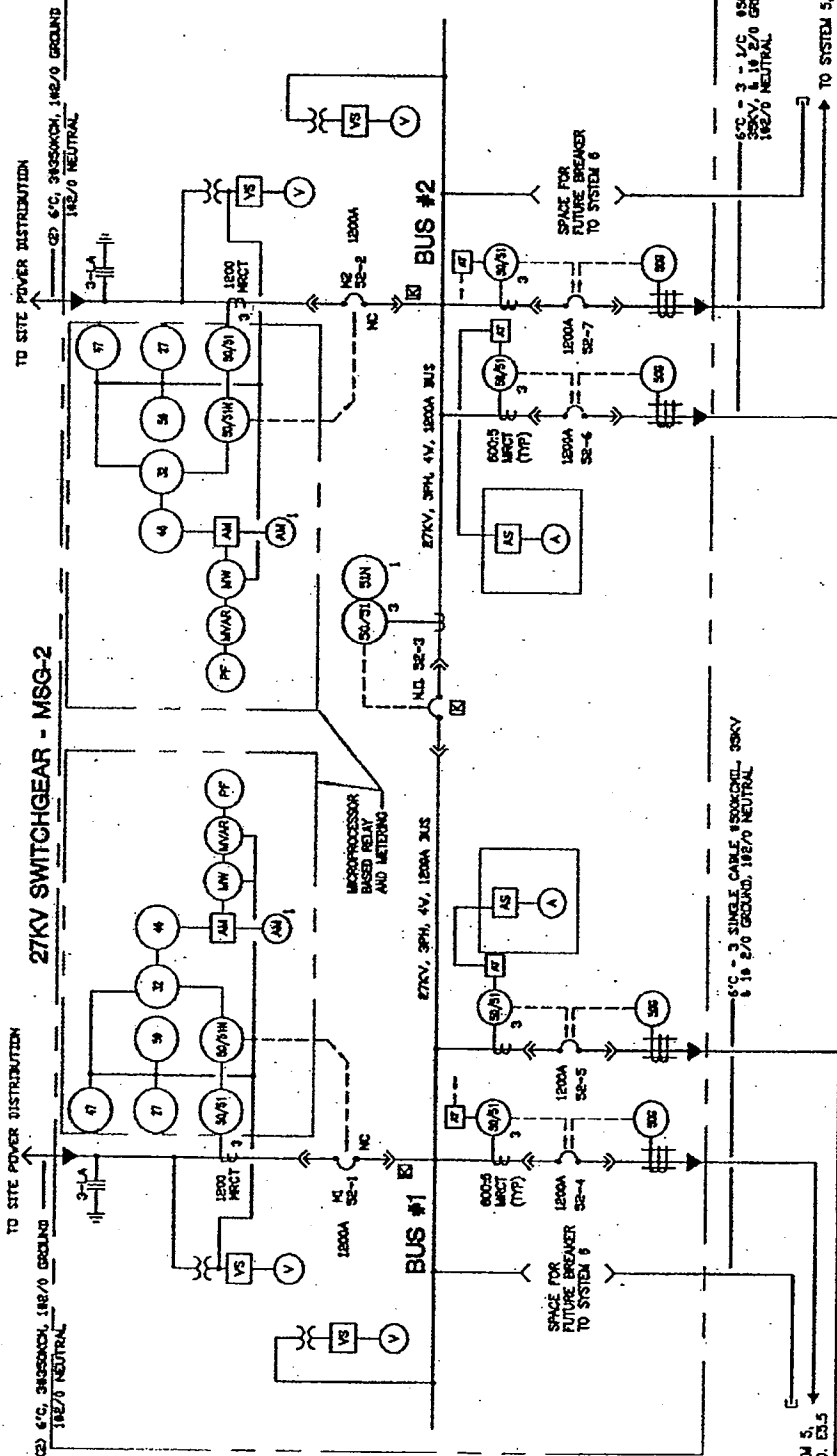

60° 5°C - 3 - 1/2" 182/0 GROUND, 182/0 NEUTRAL

50/20 BUS

600A MRCCT (TYP)

1200A MRCCT (SE-4)

1200A MRCCT (SE-5)

TO SYSTEM 5, SHEET NO. ES.5 (FUTURE)

TO SYSTEM 5, SHEET NO. ES.5 (FUTURE)

SPACE FOR FUTURE BREAKER TO SYSTEM 6

SPACE FOR FUTURE BREAKER TO SYSTEM 6

SPACE FOR FUTURE BREAKER TO SYSTEM 6

SPACE FOR FUTURE BREAKER TO SYSTEM 6

SPACE FOR FUTURE BREAKER TO SYSTEM 6

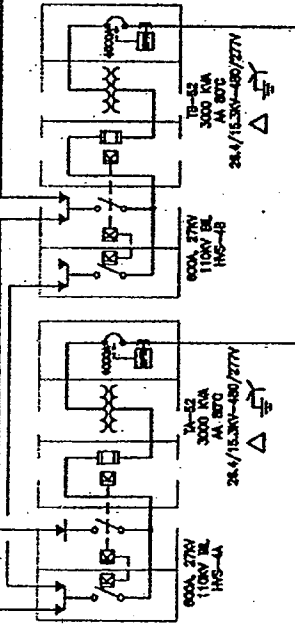

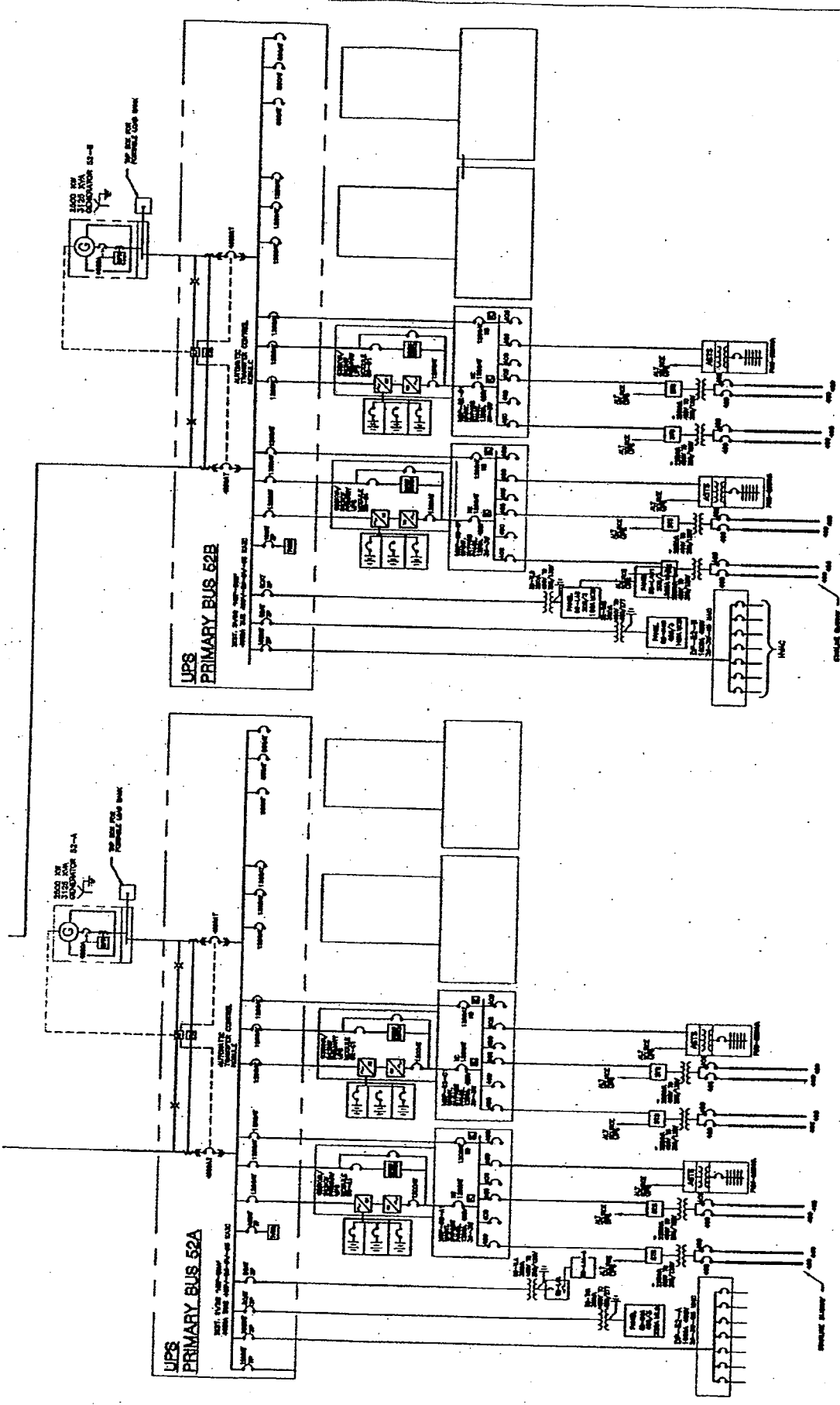

IX. Communications and Racks

Included below is the documentation from Cochran for the communications cabling and racks. This was initially outside the scope of this project but at the request of King County is now included.

November 16, 2007

To: Marcelo Garces
Sabey Construction

RE: King County Data Center -- Draft Design
Communication Design Criteria / Specifications / Clarifications/ Deviations

Attached is our Drawing Package for the Telecommunications portion of the King County Data Center at the Intergate East Campus. It includes a one line drawing schematic of how we propose the cabling would support the hardware needs, and 1st draft of the DD set of the telecommunications floor plans. Additional Elevation drawings and details are available for further clarification if needed.

In addition, please review the following sections for clarifications of our draft design.

Design Criteria Changes/ Clarifications/ Deviations

Major Design Changes affecting Budget

Value Engineering Ideas

Design Scope Changes from Original Budget

Kind Regards,

Alex Walkup
Project Engineer
Cochran Technologies
206-719-3425 cell
awalkup@cochraninc.com
www.cochraninc.com
"Integrity. Innovation. Quality"

Design Criteria Changes/ Clarifications/ Deviations

I have defined three types of Scope clarifications from the original documents in order to clarify my notes on changes to the Design criteria documents. These consist of the following types, listed below.

- 1) **Clarifications:** Note site specific features that effect the design criteria
- 2) **TBD (to be determined):** Scope and budgets not definable until customer identifies hardware type and quantities. Completion of audits and instruction from future Move Consultant and King County stake holders will be needed in order to solidify these items.
- 3) **Design Change:** Based on meetings held with King County Representatives

King County Data Center Design Criteria - Telecommunications **February 16, 2007 – Sazan Group Project No. 298-0612**

3.3 Data Center Communications Systems

3.3 A. 3. Coax Backbone Requirements and Budget to be determined(TBD) when cell phone/PCS communication hardware is identified.

3.3 A. 5. Wireless Connectivity to KCPAN Requirements and Budget to be determined when wireless hardware is identified.

3.3 A. 6. Wireless Connectivity to KCWAN Requirements and Budget to be determined when wireless hardware is identified.

4.2 Data Center Structure

4.2 A. 1. Clarification: There is only a single Entrance room for the Data Center

7.2 Telecommunications Cabling

7.2 B. 2. b. 1. Design Change: Multimode will be 50-um

7.5 Equipment Cabinets

7.5 A. Accessories: Blanking panels/208V 3-phase, 30A Cabinet Distribution units Requirements and Budget quantities to be determined when actual cabinet hardware density is identified

7.5 A. 1. To Be Determined (currently not incorporated into design or budget): Customer has recently requested different cabinets. 45 rack units Teraframe Solution by Chatsworth (FF3U-112C-C22 for Zero cab, FF2U-112C-C22 for cabinet) as Per Rick Gideon and David Millar. As per David and

Rick's email, the FF2U-110C-C22 is the preferred type for server cabinets, however the FF2U-110C-C22 has no rear door, and as such, I have changed their part #s to allow for one. Same for the FF3U-112C-C22.

*In addition, these new cabinets are different widths than the cabinets listed in the specifications. 27.6 inches wide for the server cabinets, and 31.5" for the Zero IDF/Zone Cabinet.

7.7 Connector Blocks (Systimax VisiPatch 360 System)

7.7 B. Clarification: Future space will be left vertically on the bottom two thirds for workstation terminations and PBX extensions. (Due to the top one third being used for backbone and network interface cables.)

7.11 Telecommunications Outlet/Connector Assemblies

7.11 A. 8. Clarification: Jacks shall be labeled as "A", "B", "C", and "D" (due to some locations have 4 cables per location.)

7.11 C. 1 Design Change: Optical Fiber Connectors will be 50um multimode.

Major Design Changes affecting Budget

Increased quantity of Cabinets from 85 to 131 for budget purposes
(aprox. 70k in added costs)

Increased from 24 ports per cabinet to 72 ports per cabinet & Significantly Increased Preterminated
Hydra quantities
(aprox. 560k in added costs)

Changed Backbone Fiber to 144strand Multimode and 144strand Singlemode
(aprox. 35k in added costs)

Cat.5e Cable Solution Budget

Revised Budgetary Sell Price	\$	969,229
-------------------------------------	-----------	----------------

Original Budgetary Sell Price	\$	422,504
--------------------------------------	-----------	----------------

Cat.6 Cable Solution Budget

Revised Budgetary Sell Price	\$	1,080,873
-------------------------------------	-----------	------------------

Original Budgetary Sell Price	\$	457,559
--------------------------------------	-----------	----------------

Budget Pricing does not include sales tax and is valid for 30 days.

Value Engineering Ideas

Switching from Cat.6 to Cat.5e would save approx. 110k in added costs while still supporting gigabit Ethernet.

I have provided alternate budget pricing for a Cat.5e option and a Cat.6 augmented 10-gig capable solution. Both Cat.5e and Cat.6 are approved for 1000BaseT (or 1-gig) network connections. Cat.6 isn't any faster, though it provides better headroom for extreme environments where distance from the termination points is an issue. For shorter runs in a controlled environment, Cat.5e from a high end manufacturer (like Systimax) that exceeds standards is just as good as Cat.6. Cat.6 augmented is designed for equipment capable of 10-Gig speeds. While equipment capable of these speeds over copper is currently rare, it will become much more frequent and less expensive over the next couple of years.

I expect widespread use within four years, similar to the cycle we saw with 1 gig. If the customer plans to stay in this location for more than four years, I would strongly recommend a combination of a Cat.5e and Cat.6 augmented 10-Gig solution. Cat.6 has been shown to do a limited distance of 10gig, depending on the quality of the solution you choose and quality of installation combined with environmental factors. However, in a non-plenum rated environment where the cable cost ceases to be such a factor, a Cat6 augmented solution provides more value and the assurance that the system will handle 10gig speeds readily.

Our original pricing assumed that we would be installing at a minimum providing 1056 switch ports for distribution to the cabinet rows. Assuming potential growth of 200%, we had recommended providing a minimum of 24 copper ports per cabinet and 24 fiber ports per zone (approximately 8-10 cabinets per zone), which would provide us with approx. 12 ports per cabinet of network connectivity to start and 12 ports for future growth. Revised Design as per Rick G. has 72 ports per cabinet, with 24 ports for Ethernet, 24 ports for storage, and 24 ports for Out-of-Band.

Pricing for patch cords, blanking panels, and other items with undefined quantities are not included in the budget at this time, as specific quantities will need to be identified before ordering. Price also does not include any electrical scope (basket tray, receptacles, power strips, grounding, etc) as instructed during the original site walkthrough.

Design Scope Changes from Original Budget

Final Design requires completed audits of systems to be moved, SAN requirements defined (I-SCSI cabling requirements?), and quantity agreements for misc. items such as patch cords, blanking panels, etc.

Provide and Install (116) CPI "Server Cabinets" and (12) CPI "Network Cabinets" in the data center 40x area.

Provide and Install from IDF/Zone Network Cabinet to each Server Cabinet (2)12 pack Hydra Cat.6 cables to 24 port Patch Panels and (48) Cat.6 cables to 24 port Patch Panels

Provide and Install Cat.6 Cabling for (55) Outlets in Office and NOC. 4 jacks/4 cables per work station in the NOC. 3 jacks/3 cables per work station in office areas. Provide (4) Wall phone outlets with 1 jack/1 cable at TBD locations.

Provide and Install audio visual cabling for Conference Room consisting of (1) VGA cable, (1) component video cable, and (1) S-Video Cable from Ceiling projector location to outlet in same room.

Provide and Install (72) ports of Cat.6 Feeds for (8) TBD Misc. Data Center Areas outside of the Hot Aisle cabinet enclosures.

Provide and Install (1) 48 strand 50um multimode fiber cables from the MDF Fiber Rack to each (12) IDF/Zone Network Cabinet.

Provide and Install (1) 144 strand 50um multimode and (1) 144 strand singlemode fiber optic cable from the MDF Fiber Rack to the Entrance/Demarc room.

Provide and Install 2x2 Fiber tray in IDF rows and MDF rows for Fiber patch cord routing

Provide and Install Visipatch 360 wall field in 1st Floor offices IDF for all Terminations for this area.

Provide and Install 100 pair Riser feed from MDF to 1st Floor office IDF for voice connections

Provide and Install (1) 24 strand Multimode and (1) 24 strand Singlemode Fiber optic cable to 1st Floor office IDF.

Provide and Install (1) 48 strand Multimode 50um Fiber Optic Cable from the MDF to each (12) IDF/Zone Cabinet.

KC DC - Sabey Cat.6 Option

Original Qty	Qty	Unit	Manf.	Description
Station Locations (Tie to VisiPatch)				
	221	ea	Systemax	RJ-45 Jack CAT6
	55	ea	Systemax	4-Port Faceplate
	55	ea	Systemax	Dust Cover/Blank
	1	ea	Systemax	Wallphone Plate
	38675	ft	Systemax	CAT6 Cable Plenum
	4	ea	Systemax	VP360-12U-96P Visipatch 360 Wall Field
	4	ea	Systemax	VP360-12U-10VTCM Visipatch 360 Vertical CM
	2	ea	Systemax	VP360-HCM-KIT-27 Visipatch 360 Horizontal CM 37"
	4000	ft	Systemax	RG-6 Plenum Cable for NOC video connections
	4	ea	Systemax	1-Port Faceplate
	8	ea	Systemax	F-Type Connector Insert
Cabinet Cabling				
	8976	ea	Cochran	Per Port Pull Cable from IDF/Zone Rack to Server Cabinets
	538560	ft.	Systemax	CAT6 PVC Cable for Hydras and Telco Ties
	508	ea	Systemax	24-Port CAT6 Patch Panels for Cabinet Ties(3 per Cabinet)
	0	ea	Systemax	24-Port UMP Blank Panels
	496	ea	Systemax	Hydra cabling - 12 packs (3 per Server Cabinet Budgeted)
Racks				
	14	ea	CPI	7' x 19" Racks
	14	ea	CPI	Rack base dust cover
	14	ea	CPI	Rack Top Mount Cable trough
	12	ea	CPI	MCS-EFX Master Cabling Section
	2	ea	CPI	CCS-EFX Combination Cabling Section
	14	ea	CPI	Large Horizontal Ring Panel
	50	ea	CPI	Small Peripheral Shelf
	50	ea	CPI	Heavy Duty Equipment Shelf
	50	ea	CPI	Double Sided Equipment Shelf
	14	ea	CPI	Concrete Floor Installation Kit
	14	ea	CPI	Rack Seismic Gusset Kit
	14	ea	CPI	10" Cable Runway Dropout
Cabinets				
	116	ea	CPI	TeraFrame Series 24" wide freestanding modular type
	116	ea	CPI	Multi-Mount Hardware Kit
	116	ea	CPI	Large Horizontal Ring Panel
	1	ea	CPI	MegaFrame Fixed Shelf
	1	ea	CPI	Filler Panel 4u
	1	ea	CPI	Filler Panel 6u
	1	ea	CPI	Filler Panel 10u
	1	ea	CPI	Snap-in filler panel 1u
	1	ea	CPI	Snap-in filler panel 1u (square punch)
	1	ea	CPI	Snap-in filler panel 2u

1	ea	CPI	Snap-in filler panel 2u (square punch)
131	ft	CPI	concrete Floor installation Kit
Copper and Fiber Riser			
0	ft	Corning	24-Strand SM 8/125 OFNR Fiber Cable
0	ft	Corning	24-Strand MM 62.5/125 OFNR Fiber Cable
1000	ft	Corning	24-Strand SM 8/125 OFNP Fiber Cable
1000	ft	Corning	24-Strand MM 62.5/125 OFNP Fiber Cable
1500	ft	Corning	48-Strand SM 8/125 OFNR Fiber Cable
3300	ft	Corning	48-Strand MM 50/125 OFNR Fiber Cable
500	ft	Mohawk	300x CMR Cable
500	ft	Mohawk	50x CMR Cable PBX connections to Visipatch field
500	ft	Belden	CATV Backbone Cable
4	ea	Corning	1U Rack Mount Fiber Enclosure
2	ea	Corning	4U Rack Mount Fiber Enclosure
56	ea	Corning	12-Port LC MM Adapter Panel
56	ea	Corning	12-Port LC SM Adapter Panel
864	ea	Corning	LC MM Fiber Connectors
288	ea	Corning	LC SM Fiber Connectors
Closet Hardware			
12	ea	CPI	7' x 19" Racks
2	ea	CPI	Vertical Wire Management 7'hX6"w Double Sided
11	ea	CPI	Vertical Wire Management 7'hX12"w Double Sided
20	ea	Systemax	VP360-12U-96P Visipatch 360 Wall Field
20	ea	Systemax	VP360-12U-10VTCM Visipatch 360 Vertical CM
10	ea	Systemax	VP360-HCM-KIT-27 Visipatch 360 Horizontal CM 37"
Misc			
1	Lot	Cochran	Misc Materials & Terminations
300	ea	Cochran	Cable Pathways
1	ea	Cochran	Permit
1	Lot		Firestopping

Revised	\$	
Budgetary Sell Price		1,080,873

Original	\$	
Budgetary Sell Price		457,559

X. SDC52 Design Peer Review RFP

Below is the cover letter for our Peer Review document that we sent out for competitive bid. The peer review contract was awarded to Glumac

Sabey DataCenter 52 (SDC 52)

Peer Review Request for Proposals

Background

Sabey DataCenter (SDC) is developing a scalable data center and desires to contract for electrical and mechanical design peer review.

The design reviewers will focus on: (1) identifying any single points of failure that may have been missed by the designers, (2) checking relevant design calculations, and (3) identifying general areas of opportunity for design improvement – especially from a standpoint of reliability enhancement and cost savings. Initial cost and TCO are both of concern – point out opportunities for energy conservation and utility rebates.

The design reviewers will review design documents at three major design milestones. The design reviewers will provide a report outlining their comments. The design reviewers will allot a reasonable amount of time for communication between the designer, design reviewer, and developer.

Design reviewers may propose on just the electrical design, just the mechanical design, or both. In addition to a firm price for the basic scope, respondents will list hourly rates for additional work.

The project schedule is aggressive. Design reviewers will commit to be prompt and thorough in their reviews. Design reviewers will indicate in their response the amount of time they will require to produce a report on each design step.

Design reviewers will indicate in their proposal their company's qualifications for doing the proposed work and the individual(s) proposed for this job. Design reviewers will indicate their philosophy in conducting peer review.

SDC will evaluate proposals based on price, schedule responsiveness, and qualifications. SDC may choose to award the design reviews to one company, separate companies, or none of the companies.

At this time, SDC only intends to conduct peer review of the major systems (electrical and mechanical). Responding firms may provide optional proposals for reviewing other systems (architectural, fire, etc.) The price for such proposals should be broken out separately.

The design review price will be for Phase 1. It will include overall feasibility for building Phases 2 and 3, but it will not include the exact details of those designs.

XI. Project Team

Developer - Sabey DataCenter (SDC)
Architect - Callison
Structural Engineer- Engineers Northwest
General Contractor - Sabey Construction
Electrical Contractor- Veca Electric
Mechanical Design-McKinstry
Design Review- Glumac
Communications- Cochran

As the Developer, SDC leads the project team.

Sabey Corporation began building computer rooms, as they were called then, in 1983 for Boeing Computer Services. During that time we also built-out the Abasco computer room and the regional computer center for ADP.

The design reviewers will focus on: (1) identifying any single points of failure that may have been missed by the designers, (2) checking relevant calculations, and (3) identifying any general areas of opportunity for design improvement.

The tenants, and their representatives, will be involved in the design to varying levels (up to and including design approval), depending on the specifics of their agreements with SDC.

XII. Sabey Overview

For over 38 years Sabey Corporation – a \$500 million commercial real estate development company – and its affiliate, Sabey Construction, Inc. (SCI), have constructed, renovated, and redeveloped over 27 million square feet of office, data center, manufacturing, warehouse, and retail space for hundreds of clients – Fortune 500 companies, institutions of higher education, and branches of the U.S. Government.



Today, we own and manage over 4.5 million

square feet of office, technology, data center, industrial and residential properties in Washington State and have current construction projects totaling over \$100 million. Sabey has either owned or constructed projects in California, Oregon, Texas, Utah, Alaska, Idaho, Arizona, Montana, and of course, Washington. Seventy-five percent of our portfolio is leased to marquee companies, including Group Health, American Express, Washington Mutual, Qwest Communications, Hearst Newspapers, Microsoft, Swedish Medical Center, United States Government, SAVVIS and Internap.

Our construction experience is diverse, ranging in size from \$10,000 to over \$150 million. Each new building is a challenge, whether it is the renovation of an existing building or new construction.

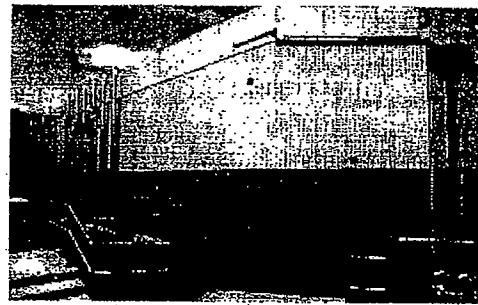

Some projects have been extremely specialized, like the high-security buildings in which Boeing Airplane Company designed and built the B-2 bomber, or the newly constructed Department of Homeland Security Regional Headquarters; many are highly technical such as bio-tech and electronic clean rooms designed for cancer research and chip manufacturing or collocation and

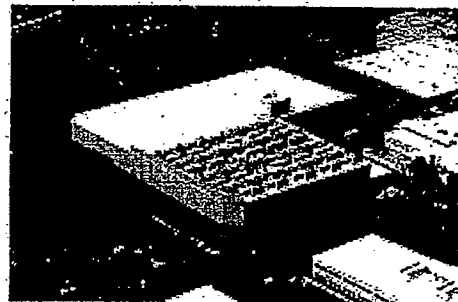

data center spaces designed with 100% redundant systems; still others are unique to the region, such as

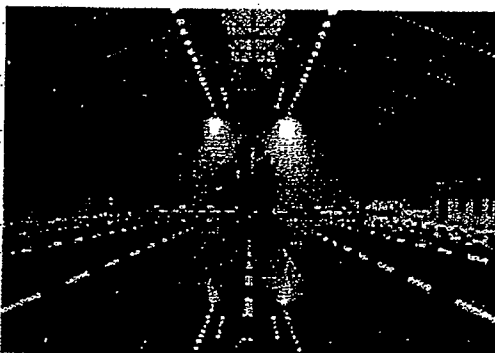

the King County Aquatics complex built for the U.S. – Soviet Goodwill games in 1990. None of these projects were standard development and construction jobs – either the timeline was unusually short or the structure highly

specialized. Presented with these challenges, we excel.

In every instance, what has helped the process along is our in-house full service capability,

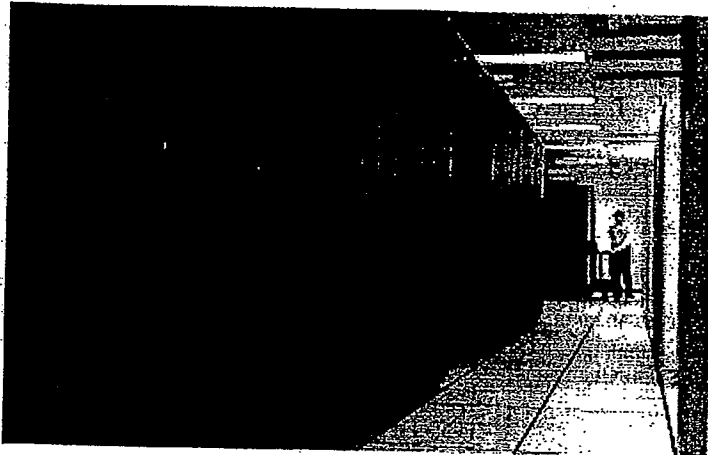

including development, construction, architecture and planning, property management, leasing and marketing divisions. Within these areas, Sabey Corporation and Sabey Construction, Inc. have

and

the ability to provide any one or all of the steps necessary to develop or redevelop property:

- Code analysis
- Construction management
- Estimating
- Entitlement
- Environmental assessments
- Financial and cash flow analysis
- Leasing
- Legal
- Marketing
- Planning and permitting
- Space planning
- Tenant Improvement

Sabey Construction Services

Sabey Construction, Inc. (SCI) brings decades of experience to each project. Because we frequently build for our own account, SCI offers a full range of in-house services that extend far beyond those normally available through

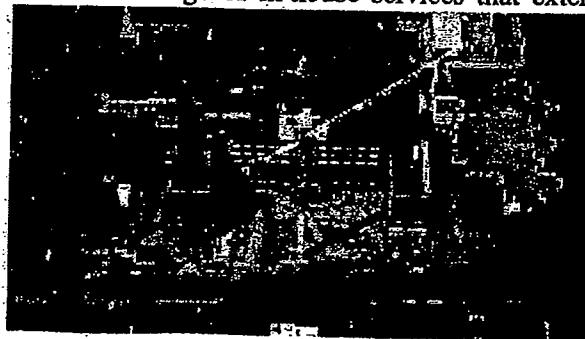

general contractors, including: site research and acquisition, land reclamation, complete construction management, post-construction follow through, and assistance in planning for future expansion or changes in use. Our staff includes professionals in estimating, purchasing, cost scheduling, accounting, and management support as well as experienced project managers, superintendents and foremen.

In addition, SCI has the in-house support of Sabey Architecture, financial and legal services, as well as a number of consulting/engineering firms with whom we have established close working

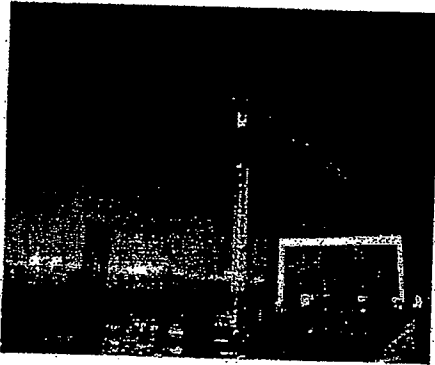

relationships over the years.

SCI is able to field a professional crew wherever needed. We are able to increase capacity to meet unusual jobs and time requirements while maintaining excellent quality, thorough safety standards and buttoned-down cost control. And, SCI is very successful at accelerating

timeframes, for instance by overlapping activities and managing more trades on a job site, so that our customers are up and running faster than they might expect.

A strong working relationship is created in all Sabey Corporation/Construction design/build projects by emphasizing the importance of team effort. development experts, engineers, estimators, project and other project professionals within arm's reach has our clients an extremely responsive team, adept at problem-solving. Being under the same roof allows us to define clear channels of communication and division of responsibility early in any project. Through this team approach, Sabey Corporation and SCI offer the unique ability to provide a seamless flow from development to design



Having managers, afforded solving. of

requirements through construction and into the opening of a facility. This premise holds true if projects are developed using in-house services or teamed up with outside architectural and engineering firms to deliver projects for our clients that are on time and on budget.

Using SCI as a resource throughout the development life cycle is a great example of how we use our powerful resources to the customer's advantage. SCI's ability to move in tandem with the entitlement phase, thereby maximizing the team's time-lines, will provide the earliest practical delivery of the best fit for this overall development. Numerous examples and details exist as to our method of maximizing the optimal outcome from the proposed team and will remain as evidence resonating from the demonstration of excellence through execution.

We are uniquely qualified for and gravitate to real estate solutions that offer less orthodox delivery methods and challenge us to "think outside the nine dots." Our comprehensive and world class network of business partners provides scale, perspective and value to our customers. Based on our long term success and

experience with both our own estate developments and our significant third party services (including development, design,

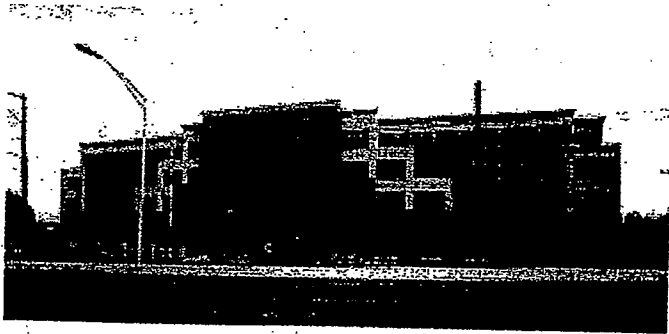

real

construction, leasing and facility operations), we are confident that our team will provide King County with the value-added real estate solution it seeks.

le

ce



Project name	Review group	Review Date	Issue Date	Person Responsible to Make Change
King County Data Center - SDC 52 01				
D Miller, Sazan group, OIRM project team				
PRELIMINARY COMMENTS on Sabey Design Development submittal dated 11/14/2007 and Basis of Design Narrative - Not dated				
Review Comment #	Drawing No. OR, Spsa Section and Page No.	Reviewer Initials	Reply by:	Sabey Reply
1	General	DM	Callison	Will coordinate w/Callison
2	General	DM	Sabey	Additional design work/cost/line. Is this an authorization to proceed? Will coordinate w/Callison
3	Architectural	DM	Callison	Yes, as laid out in Oct. DD set.
4	Architectural	DM	Sabey	Agreed
5	Electrical	DM	Vece	Harmonic filtering is included in the MSE modules
6	Electrical	RG	Vece	There are not separate IT and mechanical buses. Each bus has UPS modules and mechanical equipment.
7	Electrical	RG	Vece	Pending KC final Comm recommendations. Sabey to work w/Cochran on redesign.
8	Communications	RG	Vece	Pending KC final Comm recommendations. Sabey to work w/Cochran on redesign.
9	Communications	RG	Sabey/ Cochran	Pending KC final Comm recommendations. Sabey to work w/Cochran on redesign.
10	Communications	RG	Sabey/ Cochran	Pending KC final Comm recommendations. Sabey to work w/Cochran on redesign.
11	Communications	RG	Sabey/ Cochran	Pending KC final Comm recommendations. Sabey to work w/Cochran on redesign.
12	Communications	RG	Sabey/ Cochran	Small additional price for locking junction boxes. The MPOE and Telco rooms, through which some of this cabling is routed, are secure spaces with cameras and access control. There are a relatively small number of people, including landlord staff, landlord security and a few carrier and tenant personnel, who have access to these rooms.
13	Electrical	RG	Sabey/ Cochran	Pending KC final Comm recommendations. Sabey to work w/Cochran on redesign.
14	Electrical	RG	Sabey/ Cochran	Pending KC final Comm recommendations. Sabey to work w/Cochran on redesign.
15	Electrical	RG	Sabey/ Cochran	Pending KC final Comm recommendations. Sabey to work w/Cochran on redesign.
16		DM	Sabey/ Vece	Pending KC final Security design. Sabey to work w/Vece on opening placement.

Project name	King County Data Center - SDC 52.01		Issue Date:	Person Responsible to Make Change
Review group	D Miller, Sazan group, CIRI project team		3/5/08	3/17/08
PRELIMINARY COMMENTS on Sabey Design Development submittal dated 11/14/2007 and Basis of Design Narrative - Not dated				
Review Comment #	Drawing No., OR Spec Section and Page No.	Reviewer's Initials	Reply by:	Issue Date:
28	E-109 & E-7.25 Review Comments Provide a 4"x4" fiber duct system to be designed and installed on top of the entire cable tray system designed for the 2nd floor KC DC area and have proper downspout modules installed to provide access to all the zone cabinets on the floor as well as the equipment racks in MDF area. Same ADC 4x4 Fiber/Guide Fiber Management System installed by Sabey for the Carrier area of Building 2 shall be acceptable to KC. The design of the fiber duct system and materials for KC Data Center shall be subject to KC's approval.	HS	Sabey Reply Add Alternate pricing to be provided. Add to drawings.	3/25/08
29	E-5.4 & E-3.25 The KC Office area on 1st floor needs to be on the same back up power system for DC.	HS	Vece Add Alternate pricing to be provided. The original scope allowed for a certain number of outlets in the office area that would be on UPS power from the DC. If the whole office it to be on UPS power (except the lights and HVAC) Pending KC final Comm recommendations, Sabey to work w/Cochran on redesign.	3/28/08
30	E-7.25 provide (1) 24MM fiber and (1) 24MM fiber and a 50 pr. copper cables between MDF and the IDF closet in the KC Office area on 1st floor in the (2) 4 inch conduit links specified above.	HS	Sabey/ Cochran	Agreed
31	E-3.11 Provide additional jacks in the Production Engineering Office Area	CB	Sabey/ Cochran	Agreed
32	E-7.25 What is the raceway from server area through vestibule through the women's bathroom to what? (IDF room?)	CB	Vece	Agreed
33	A-802 Verify A1 window is designed for wheelchair visibility.	CB	Callison	Agreed
34	Many documents (text, drawings) cover the same issues and systems. Some contradict others. Provide order of precedence of documentation. Provide cable tray sizes	CB	Sabey/ Callison	Agreed
35	Change blackboard to Whiteboard	CB	Callison	Agreed
36	A-700 Provide exiting plans	CB	Callison	Agreed
37	A-102 Provide separate 4" fiber tray inside data center	CB	Callison	Agreed
38	MDF racks need to be seismically braced to the wall	CB/RK	Vece/ Callison	Agreed
39	Using STS not PDUs. Drawings are incorrect and incomplete. Correct drawings	CB/RK	Vece	Agreed
40	No security plan. Check with Dan Kenoyer. Indicate cameras & card key access on plans	CB/RK	Sabey/Vece	Agreed
41	Cable proposal is incomplete and inconsistent with previously issued cable topology description. Revise cable proposal per Essential Performance Requirements	CB	Sabey/ Cochran	Agreed
42	Communications	CB	Sabey/ Cochran	Agreed
43	KCDQ DD Sabey responses to KC feedback 03/26/08			Agreed

Project name **King County Data Center - SDC 52.01**

Review group **D. Miller, Sazan group, OIRM project team**

PRELIMINARY COMMENTS on Sabey Design Development submittal dated 11/14/2007 and Basis of Design Narrative - Not dated

Review Comment #	Drawing No. OR Spec Section and Page No.	Review Comments	Reviewer Initials	Reply by:	Issue Date:	Person Responsible to Make Change
54	Mechanical - MO.1	What is the anticipated temperature in the hot aisle plenums?	Sazan	Sabey Reply Anticipated hot aisle plenum temperature approximately 88-92F. Similar server equipment on other jobs indicates 20°F temperature difference is conservative. Will analyze upon receipt of know tenant equipment.	3/17/08	
55	Mechanical - MO.3	Critical summary indicates tenant load at 91 watts/sf. This is not in accordance with King County Essential Performance Requirements. Verify 150 wsf.	Sazan	McKinstry Direction for total tenant load was given as 1.05 MW, no criteria specified in watts/SF.	3/27/08	
56	Mechanical - MO.1	Provide a tabulation of shared system capacities with planned future expansion and anticipated maximum capacities.	Sazan	McKinstry Will provide, please clarify what future expansion and anticipated max capacities are desired. i.e. equipment? ductwork sizing? enclosure limits?	3/26/08	
57	Mechanical - MO.1	There is reference to legacy equipment area. Identify the legacy area on floor plans.	Sazan	McKinstry Will indicate		
58	Mechanical - MO.1	Clarify what ductwork revisions could be required in the future (see 4th paragraph, first column).	Sazan	McKinstry Provisions for future expansion can be provided upon coordination with architect and tenant.		
59	Mechanical - MO.1	Clarify last sentence of fifth paragraph on first column of text.	Sazan	McKinstry Reviewing internally, will respond accordingly.		
60	Mechanical - MO.1	Alarm Resolution table; Condition Row 2: How would the proposed solution help the overall system (sequence of operation may clarify this)	Sazan	McKinstry Reviewing internally, will respond accordingly.		
61	Mechanical - MO.1	Alarm Resolution table; Condition Row 4: Pumps do not appear to have associated redundant pumps as suggested by control notes.	Sazan	McKinstry Reviewing internally, will respond accordingly.		
62	Mechanical - MO.1	Alarm resolution table; Condition Row 3: Why over pressurization does not shut affected air handling unit?	Sazan	McKinstry Reviewing internally, will respond accordingly.		

King County Data Center - SDC 52 01

D Miller, Sazan group, OIRM project team

PRELIMINARY COMMENTS on Sabey Design Development submittal dated 11/14/2007 and Basis of Design Narrative - Not dated

Project name	Review group	Review Comment #	Spec Section and Page No.	Reviewer Initials	Reply by:	Issue Date:	Person Responsible to Make Change
			Mechanical - M2.2	Sazan	Mckinstry	3/17/08	
		71	If KC does not expand to expansion space and a different tenant occupies the space, how would the expansion space be air conditioned?	Sazan	Mckinstry	3/21/08	
		72	Mechanical - M4.0 Detail 4. Show detail to scale to illustrate actual condition.	Sazan	Mckinstry	3/25/08	
		73	Mechanical - General Provide Load calculations used to size air handling units, exhaust fans, and chillers. Include input and output files.	Sazan	Mckinstry		
		74	Mechanical - General Provide sink for break room.	Sazan	Mckinstry		
		75	Mechanical - General Provide fire protection and VESDA drawings.	Sazan	Mckinstry		
		76	Electrical - General What is length of time generators can be kept operational at full load?	Sazan	Mckinstry		
		77	Electrical - E2(37) Partial 2nd Floor Power Plan: Number of STS's shown on plan does not match the One-Line E5.4. Clarify.	Sazan	Sabey		
		78	Electrical - E5.4 General: Feeder sizes not shown on the one-line diagram. Provide clarification.	Sazan	Veca		
		79	Electrical - E5.4 27kV Switchgear MSG-2. Feeders 52-5 and 52-6; Omit the neutral conductors.	Sazan	Veca		
		80	Electrical - E5.4 SWBD's HDP-52A & 52B; drawings should indicate a 3-Phase, 4-Wire bus rather than the 3-Phase, 3-Wire bus. Confirm requirements.	Sazan	Veca		
		81	Electrical - E5.4 SWBD's HDP-52A & 52B, these liftmost circuits: Clarify the objective of the GFR sensors. Under what conditions will the circuit breakers be tripped? If power is interrupted to the HVAC equipment, what is the contingency plan for cooling the data center?	Sazan	Veca		
		82	Electrical - E5.4 Ensure that ground-fault relays installed in HDP-52A & 52B are selectively coordinated with the units installed at TA-52 and TB-52.	Sazan	Veca		
		83	Electrical - E5.4 Distribution Panels DP 52-A1, B1, C1, and D1; Provide main circuit breakers in panels that exceed six over current protective devices.	Sazan	Veca		
		84	Electrical - E5.4 Recommend against tripping the 4000A generator circuit breakers on ground-fault. Recommend ground-fault alarm only. Confirm.	Sazan	Veca		

KCOC DD - Sabey responses to KC feedback 032608

Project name	King County Data Center - SDC 52 01		Issue Date	Person Responsible to Make Change
Review group	D. Miller, Sazan group, OIRM project team		3/5/08	3/17/08
PRELIMINARY COMMENTS on Sabey Design Development submittal dated 1/14/2007 and Basis of Design Narrative - Not dated				
Review Comment #	Drawing No. OR Spec Section and Page No.	Review Comments	Reviewer Reply by: Sabey Reply	Issue Date
100	DD Narrative	Verify that there will be no hot/cold spots outside the enclosed separated aisles. This includes MDF and legacy equipment areas.	McKinstry	3/27/08
101	DD Narrative	Basis of design HVAC temperatures shall meet KC performance requirements. Note that KC may elect to operate the system at higher temperatures at their discretion.	Sabey	3/28/08
102	DD Narrative	Narrative should delete exclusions identified by McKinstry and other subcontractors	Sabey	
103	DD Narrative	Vesda is a basic requirement. Include in Second floor areas	Vesa	
104	DD Narrative	Provide a budget allowance for Coax Backbones, KCPAN and KCWAN	Sabey/ Cochran	
105	DD Narrative	Allow for 48 ports per Server cabinet to Zone cabinet in lieu of 72 indicated	Sabey/ Cochran	
106	DD Narrative	Backbone fiber needs to be single mode rather than multimode	Sabey/ Cochran	
107	DD Narrative	Cat 5e does not meet KC standards	Sabey/ Cochran	
108	DD Narrative	Allow for 3,840 server communication ports for 80 server cabinets	Sabey/ Cochran	

EXHIBIT D
TO LEASE AGREEMENT
RULES AND REGULATIONS

1. Any directory provided by Landlord for the Building will be for the display of the name and location of tenants of the Building, and Landlord reserves the right to exclude any other names from inclusion in any such directory.
2. Tenant shall not place any new or additional locks on any doors of the Premises or re-key any existing locks without the prior written consent of Landlord.
3. Landlord reserves the right to exclude or expel from the common areas any person who, in the sole judgment of Landlord, is intoxicated, under the influence of drugs or who shall in any manner violate any of these Rules and Regulations.
4. Tenant shall not do or permit to be done within the Premises, the building or parking loading or other adjoining common areas, anything, which would unreasonably annoy or interfere with the rights of other tenants of the Building.
5. Tenant shall not permit its employees or invitees to loiter in or about the common areas or obstruct any of the parking, truck maneuvering or other common areas, or to place, empty or throw away rubbish, litter, trash or material of any nature upon any common areas.
6. No storage of materials, equipment or property of any kind is permitted outside the Premises unless otherwise approved in writing by Landlord and any such property may be removed by Landlord at Tenant's risk and expense.
7. Tenant shall not make or permit any use of the Premises which in the sole judgment of Landlord, may be dangerous to persons or property; permit any noise, odor or vibrations to emit from the Premises which are objectionable to Landlord or other occupants of the Building; or to create, maintain or permit a nuisance or any violation of any regulation of any governmental agency thereon.
8. Tenant shall not commit or permit to be committed any waste, damage or injury to the Premises, the Building or parking, loading and other common areas adjoining and shall promptly notify Landlord in writing of such waste, damage or injury and repair the same at its expense.
9. Tenant understands that any equipment required for maintenance of the Premises is Tenant's responsibility and that Landlord has no equipment available for Tenant's use therefore (e.g. ladders or lifts for re-lamping, etc.).
10. Tenant shall use the Premises and shall operate its equipment on the Premises in a safe and prudent manner, and any damage or cracks occurring in the floor of the Premises caused by Tenant shall be promptly brought to the attention of Landlord by written notice and repaired by Tenant at its expense.
11. Tenant shall not at any time display a "For Rent" sign upon the Premises.
12. Tenant agrees to cause its employees to park only in such designated areas as may be designated by Landlord from time to time for employee parking and shall abide by any rules or regulations concerning parking promulgated by Landlord, or Landlord's agent, from time to time.

13. Tenant shall not waste electricity or water and agrees to cooperate fully with Landlord to assure the most effective and economical use of utilities services as may be provided to the Building by Landlord.
14. Tenant shall keep Landlord advised of current telephone numbers of Tenant's employees who may be contacted in an emergency, i.e., fire, break-in, vandalism, etc. If Landlord shall deem it necessary, in its sole judgment, to respond to such emergency in Tenant's behalf, Tenant shall pay all costs incurred for services ordered by Landlord to secure or otherwise protect the Premises and the contents thereof, including a premium charge for any time spent by Landlord's employees in responding to such emergency.
15. Tenant shall not smoke, and shall cause its employees, contractors, agents and invitees to refrain from smoking, in the Building except in such areas as may be designated as smoking areas by Landlord, if any. In the event that Tenant desires to allow smoking in its Premises and such smoking is permitted under applicable laws, then Tenant, at Tenant's sole expense and subject to the requirements of Section 9 (Improvements And Alterations By Tenant), shall first take such action as may be necessary to have a smoke exhaust system installed in the Premises that is acceptable to Landlord.
16. No pets or other animals are permitted on the Property, including the Premises, at any time except: (i) dogs which are present on the Property or Premises in their capacity of providing assistance to a disabled person; and (ii) laboratory animals of tenants leasing laboratory space and pursuant to terms agreed upon by Landlord in writing prior to such animals being brought onto the Property.
17. Subject to the terms and conditions of this Lease, any cost incurred for direct services provided to Tenant beyond Normal Business Hours at Tenant's request, shall be reimbursable to Landlord or Landlord's Management Agent. Such direct costs to include after-hours labor charge for "on-call" assistance as may be requested by Tenant or Tenant's employees. A minimum three (3) hour charge shall be assessed per Tenant request.

**EXHIBIT E
TO
LEASE AGREEMENT
PARKING AREA**

138
-140-

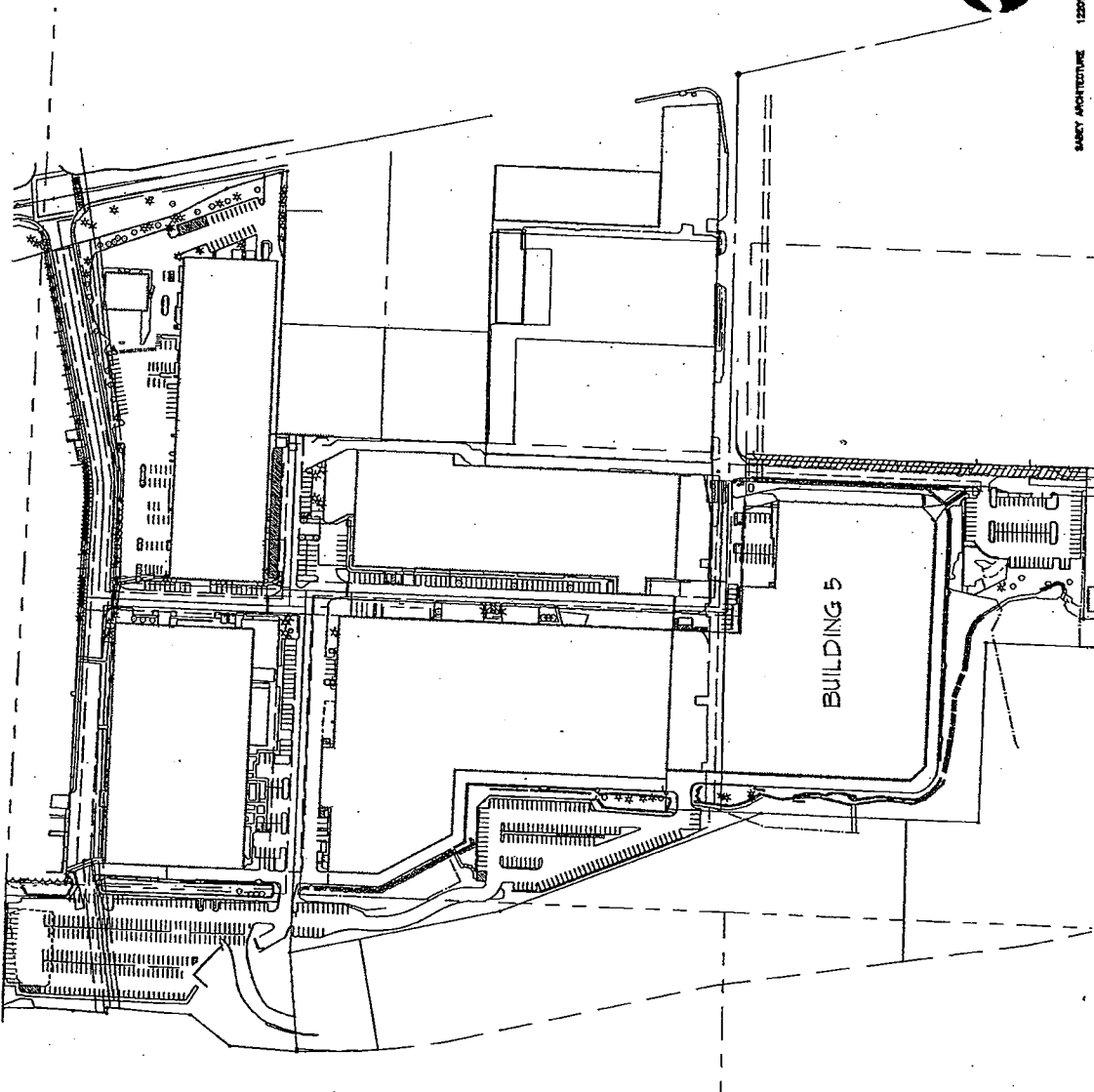

Intergate.east
 A TECHNOLOGY CAMPUS
 3355 South 120th. Street Tukwila, Washington
 (206) 251-8700 FAX (206) 252-0661



SAGEY ARCHITECTURE
 12501 TUMBLA INTERNATIONAL BLVD SEATTLE WASHINGTON 98148 (206) 251-8700 FAX (206) 252-0661

EXHIBIT B
 Parking

16213

ATTACHMENT B.

2007-443

Sazan
Group
Inc.

KING COUNTY
Data Center Design Criteria

Due Date:

February 16, 2007

Prepared For:

King County
Facilities Management Division
Seattle, WA

Prepared By:

Sazan Group, Inc.

720 Olive Way

Suite 1525

Seattle, WA 98101

Tel (206) 267-1700

Fax (206) 267-1701

INDEX

GENERAL

ARCHITECTURAL

MECHANICAL

ELECTRICAL

TELECOMMUNICATIONS

GENERAL PROVISIONS.....	2
1.0 Scope.....	2
1.1 General Requirements	2
1.2 Purpose.....	2
1.3 Design-Build Process	2
2.0 Deliverables and Design Qualifications	2
3.0 Reviewing Authority and Design Approvals	3
3.1 General	3
3.2 King County	3
3.3 Local Authorities	3
3.4 Owners Representative.....	3
4.0 References	3
5.0 Definition Of Terms, Acronyms And Abbreviations.....	8
5.1 General	8
5.2 Definitions	8
6.0 Design Criteria	9
7.0 Submittals	10
7.1 General	10
7.2 Submittal Requirements.....	10
7.3 Disciplines	10
7.4 Equipment.....	19
7.5 Specifications.....	19
8.0 Construction Documents Phase	20
8.1 Construction Document Submittals:	20
8.2 Mechanical	20
8.3 Electrical	21
9.0 Coordination.....	22
10.0 Material Requirements.....	22
11.0 Installation	23
12.0 Owner Acceptance Requirements	23
13.0 Record Documents	24
14.0 Warranty.....	24

GENERAL PROVISIONS

1.0 SCOPE

1.1 General Requirements

- A. The following is a summary of the Scope of Work for design and construction of the architectural, mechanical, electrical, and communications cabling of the new consolidated King County Data Center.
- B. The Building Owner is responsible for the design process, including the Owner's Design Architect and Contractor. All lines of communication shall be directed through King County's project manager David Millar, Facilities Management (tel 206/296-0239).

1.2 Purpose

- A. This document is intended for use by designers who need a comprehensive understanding of the architectural, mechanical, and electrical features of the data center design including the facility planning, the cabling system, and the network design.
- B. The design criteria and standards contained within are the minimums acceptable for efficiency, economy, durability, maintainability, and reliability of the mechanical HVAC, and electrical power supply and distribution systems.
- C. Clarifications of baseline design criteria, standards, policy, and guidance should be obtained through the normal communications channels established between the owner and contractor.

1.3 Design-Build Process

- A. The Design team is strongly encouraged to recommend cost saving material, equipment, and/or design alternatives.
- B. Provide all labor, materials, equipment, tools, plant, and reproduction services necessary for the development and delivery of complete design and construction for architectural, HVAC, plumbing, fire protection, power, lighting and alarm systems as described hereinafter.
- C. Provide the necessary resources to complete the work expeditiously and within requirements of published project schedule.
- D. Provide all items and work required to implement a fully functional data center. This includes all incidentals, equipment, appliances, services, scaffolding, supports, tools, supervision, labor, consumable items, fees, licenses, etc., necessary to provide complete systems.
- E. Provide all services necessary for startup, commission, and check out each item and system to provide fully operable systems.

2.0 DELIVERABLES AND DESIGN QUALIFICATIONS

- A. Complete engineering plans, specifications, and calculations for the project shall be prepared and submitted to the Owner along with estimates of probable construction costs.
- B. These documents shall be prepared, signed, and sealed by Professional Engineers, Architects, and Registered Communications Distribution Designers (RCDDs) licensed to practice in the State of Washington, and who are regularly engaged in the design of similar facilities and systems.

3.0 REVIEWING AUTHORITY AND DESIGN APPROVALS

3.1 General

- A. Comply with all applicable governmental regulations. Comply with all Federal, State, City, and other applicable codes and ordinances.
- B. If any conflict arises between the Specifications or codes and ordinances, immediately notify the Owner.

3.2 King County

- A. King County will have the final decision with respect to system concepts, visual coordination, and acceptance of proposed products.
- B. Design elements related to the telecommunications physical infrastructure are subject to review and approval by King County OIRM.
- C. See submittal requirements hereinafter.

3.3 Local Authorities

- A. Submit engineering plans, specifications, and calculations to local authorities for review in accordance with reviewing agencies instructions.
- B. Obtain and pay for all permits and pay all fees required by authorities having jurisdiction for work. Pay all royalties or fees required in connection with the use of patented devices and systems.
- C. Arrange for and schedule all tests required by authorities having jurisdiction and public or private utilities.
- D. During construction do not deviate from approved drawings and specifications nor install any work that may be in conflict with codes and ordinances.

3.4 Owners Representative

- A. Owner will retain Săzăn Group, Inc. to act on the Owner's behalf as advisors on technical matters of interest to the Owner. Their involvement in this project shall, in no way, alleviate the statutory and professional requirements and obligations of the design and construction team as the Professional Engineer of Record. The review of designs or installations shall, in no way, reduce or diminish the obligation, responsibility or liability of the design and construction team or their professional consultants.

4.0 REFERENCES

- A. The publications listed below form a part of this document to the extent referenced. The publications are referred to within the text by the basic designation only.

AMERICAN NATIONAL STANDARDS INSTITUTE (ANSI)

AMERICAN SOCIETY OF HEATING, REFRIGERATING AND AIR CONDITIONING ENGINEERS (ASHRAE)

AMERICAN SOCIETY OF MECHANICAL ENGINEERS (ASME)

ASTM INTERNATIONAL (ASTM)

ASTM B 1	(2001) Hard-Drawn Copper Wire
ASTM B 8	(2004) Concentric-Lay-Stranded Copper Conductors, Hard, Medium-Hard, or Soft
ASTM D 709	(2001) Laminated Thermosetting Materials

ELECTRONIC INDUSTRIES ALLIANCE (EIA)

ANSI/TIA-942	(2005) Telecommunications Infrastructure Standard for Data Centers
EIA TIA-455-21-A	(1988) FOTP-21 - Mating Durability of Fiber Optic Interconnecting Devices
TIA/EIA-492AAAA-A	(1998) 62.5-um Core Diameter/125-um Cladding Diameter Class 1a Graded-Index Multimode Optical Fibers (ANSI/TIA/EIA-492AAAA-A)
TIA/EIA-492CAAA	(1998; R 2002) Class IVA Dispersion-Unshifted Single-Mode Optical Fibers
TIA/EIA-526-14A	(1998) OFSTP-14A Optical Power Loss Measurements of Installed Multimode Fiber Cable Plant (ANSI/TIA/EIA-526-14A)
TIA/EIA-526-7	(1998) OFSTP-7 Measurement of Optical Power Loss of Installed Single-Mode Fiber Cable Plant (ANSI/TIA/EIA-526-7)
TIA/EIA-568-B.1	(2001; Addendum 2001) Commercial Building Telecommunications Cabling Standard - Part 1: General Requirements (ANSI/TIA/EIA-568-B.1)
TIA/EIA-568-B.2	(2001) Commercial Building Telecommunications Cabling Standard - Part 2: Balanced Twisted Pair Cabling Components (ANSI/TIA/EIA-568-B.2)
TIA/EIA-568-B.3	(2000; Addendum 2002) Optical Fiber Cabling Components Standard (ANSI/TIA/EIA-568-B.3)
TIA/EIA-569-A	(1998; Addenda 2000, 2001) Commercial Building Standards for Telecommunications Pathways and Spaces (ANSI/TIA/EIA-569-A)
TIA/EIA-598-B	(2001) Optical Fiber Cable Color Coding
TIA/EIA-604-10A	(2002) FOCIS 10 Fiber Optic Connector Intermateability Standard - Type LC
TIA/EIA-604-2	(1997; R 2002) FOCIS 2 Fiber Optic Connector Intermateability Standard

TIA/EIA-604-3A	(2000) FOCIS 3 Fiber Optic Connector Intermateability Standard - Standard Type SC
TIA/EIA-606-A	(2002) Administration Standard for the Telecommunications Infrastructure (ANSI/TIA/EIA-606)
EIA-310-D	(1992) Racks, Panels, and Associated Equipment
TIA J-STD-607-A	(2002) Commercial Building Grounding (Earthing) and Bonding Requirements for Telecommunications

INSTITUTE OF ELECTRICAL AND ELECTRONICS ENGINEERS (IEEE)

IEEE C12.7	(1993; R 1999) Requirements for Watt-hour Meter Sockets
IEEE Std 81	(1983) Guide for Measuring Earth Resistivity, Ground Impedance, and Earth Surface Potentials of a Ground System (Part 1) Normal Measurements
IEEE Std 100	(2000) The Authoritative Dictionary of IEEE Standards Terms
IEEE Std 1100	(IEEE Emerald Book) IEEE Recommended Practice for Powering and Grounding Electrical Equipment

INTERNATIONAL ELECTRICAL TESTING ASSOCIATION (NETA)

NETA ATS	(2003) Acceptance Testing Specifications
----------	--

INSULATED CABLE ENGINEERS ASSOCIATION (ICEA)

ICEA S-83-596	(2001) Fiber Optic Premises Distribution Cable
---------------	--

NATIONAL ELECTRICAL MANUFACTURERS ASSOCIATION (NEMA)

NEMA 250	(2003) Enclosures for Electrical Equipment (1000 Volts Maximum)
NEMA C12.1	(2001) Code for Electricity Metering
NEMA C80.1	(1994) Rigid Steel Conduit - Zinc Coated (GRC)
NEMA C80.3	(1994) Electrical Metallic Tubing - Zinc Coated (EMT)
NEMA FU 1	(2002) Low Voltage Cartridge Fuses
NEMA KS 1	(2001) Enclosed and Miscellaneous Distribution Equipment Switches (600 Volts Maximum)
NEMA MG 1	(2003; R 2004) Motors and Generators
NEMA ST 20	(1992; R 1997) Dry-Type Transformers for General Applications

NEMA WC 63.1	(2000) Twisted Pair Premise Voice and Data Communications Cables
NEMA WC 66	(2001) Category 5e and Category 6 100 Ohm Shielded and Unshielded Twisted Pairs
NEMA WD 1	(1999) General Color Requirements for Wiring Devices
NEMA WD 6	(2002) Wiring Devices - Dimensional Requirements
NEMA Z535.4	(2002) Product Safety Signs and Labels

NATIONAL FIRE PROTECTION ASSOCIATION (NFPA)

NFPA 70	(2005) National Electrical Code
NFPA 70E	(2004) Electrical Safety in the Workplace

SHEET METAL AND AIR CONDITIONING CONTRACTORS NATIONAL ASSOCIATION, INC. (SMACNA), SEISMIC HAZARD LEVEL AA

SEATTLE, CITY OF, REQUIREMENTS

STATE OF WASHINGTON BUILDING CODES

US FEDERAL COMMUNICATIONS COMMISSION (FCC)

FCC Part 68	Connection of Terminal Equipment to the Telephone Network (47 CFR 68)
-------------	---

UNDERWRITERS LABORATORIES (UL)

UL 1	(2005) Flexible Metal Conduit
UL 1010	(1995; Rev thru Mar 1999) Receptacle-Plug Combinations for Use in Hazardous (Classified) Locations
UL 1063	(1998; Rev thru Jun 2001) Machine-Tools Wires and Cables
UL 1242	(2000; Rev thru May 2003) Electrical Intermediate Metal Conduit
UL 1449	(1996; Rev thru Jul 2002) Transient Voltage Surge Suppressors
UL 1561	(1999; Rev thru Feb 2004) Dry-Type General Purpose Transformers
UL 248-1	(2000) Low-Voltage Fuses - Part 1: General Requirements
UL 248-2	(2000) Low-Voltage Fuses - Part 2: Class C Fuses
UL 248-4	(2000) Low-Voltage Fuses - Part 4: Class CC Fuses

UL 248-5	(2000) Low-Voltage Fuses - Part 5: Class G Fuses
UL 248-8	(2000) Low-Voltage Fuses - Part 8: Class J Fuses
UL 248-9	(2000) Low-Voltage Fuses - Part 9: Class K Fuses
UL 248-10	(2000) Low-Voltage Fuses - Part 10: Class L Fuses
UL 248-12	(2000) Low-Voltage Fuses - Part 12: Class R Fuses
UL 248-15	(2000) Low-Voltage Fuses - Part 15: Class T Fuses
UL 20	(2000; Rev thru Jun 2002) General-Use Snap Switches
UL 2043	(1996; R 2001, Jul. 2001) Fire Test for Heat and Visible Smoke Release for Discrete Products and Their Accessories Installed in Air-Handling Spaces
UL 360	(2003) Liquid-Tight Flexible Steel Conduits
UL 44	(2005) Thermoset-Insulated Wires and Cables
UL 467	(2004) Grounding and Bonding Equipment
UL 486A-486B	(2003; Rev thru Apr 2004) Wire Connectors
UL 486C	(2004) Splicing Wire Connectors
UL 489	(2002; Rev thru May 2003) Molded-Case Circuit Breakers, Molded-Case Switches, and Circuit-Breaker Enclosures
UL 498	(2001; Rev thru Oct 2002) Attachment Plugs and Receptacles
UL 5	(2004) Surface Metal Raceways and Fittings
UL 50	(1995; Rev thru Sep 2003) Enclosures for Electrical Equipment
UL 506	(2000; Rev thru Feb 2004) Specialty Transformers
UL 510	(2005) Polyvinyl Chloride, Polyethylene, and Rubber Insulating Tape
UL 512	(1993; Rev thru Mar 1999) Fuseholders
UL 514A	(2004) Metallic Outlet Boxes
UL 514B	(2004) Conduit, Tubing and Cable Fittings
UL 6	(2000; Rev thru May 2003) Rigid Metal Conduit
UL 67	(1993; Rev thru Nov 2003) Panelboards

UL 797	(2004) Electrical Metallic Tubing
UL 817	(2001; Rev thru Jan 2004) Cord Sets and Power-Supply Cords
UL 83	(2003; Rev thru Mar 2004) Thermoplastic-Insulated Wires and Cables
UL 869A	(1998) Reference Standard for Service Equipment
UL 870	(1995; Rev thru Jul 2003) Wireways, Auxiliary Gutters, and Associated Fittings
UL 943	(2006) Ground-Fault Circuit-Interrupters
UL 1286	(1999; Rev thru Oct 2002) Office Furnishings
UL 1666	(2000; Rev thru Jul 2002) Test for Flame Propagation Height of Electrical and Optical-Fiber Cables Installed Vertically in Shafts
UL 1863	(2004) Communication Circuit Accessories
UL 444	(2002; Rev thru Aug 2002) Communications Cables
UL 467	(2004) Grounding and Bonding Equipment
UL 50	(1995; Rev thru Sep 2003) Enclosures for Electrical Equipment
UL 910	(1998) Test for Flame-Propagation and Smoke-Density Values for Electrical and Optical-Fiber Cables Used in Spaces Transporting Environmental Air
UL 969	(1995; Rev thru Nov 2001) Marking and Labeling Systems

WASHINGTON STATE ENERGY CODE WITH SEATTLE AMENDMENTS

5.0 DEFINITION OF TERMS, ACRONYMS AND ABBREVIATIONS

5.1 **General**

- A. Unless otherwise specified or indicated, electrical and electronics terms used in this specification shall be as defined in TIA/EIA-568-B.1, TIA/EIA-568-B.2, TIA/EIA-568-B.3, TIA/EIA-569-A, TIA/EIA-606-A and IEEE Std 100 and herein.

5.2 **Definitions**

- A. **ADA:** Americans with Disabilities Act
- B. **BICSI:** Building Industry Consulting Service International is a professional telecommunications association.
- C. **County Enterprise Network:** The network commonly used to conduct county business that provides transport of data within and between county facilities and other agencies of county government. This definition also refers to the network used to transport data

between the county, other government agencies and the Internet. It does not refer to networks built for the sole purpose of meeting special operations needs of county business units which include, but are not limited to, process control and supervisory control networks. Nor does it refer to the King County Institutional Network (I-Net) which is required to meet contractual obligations with I-Net customers and the local cable utility.

- D. **Cross Zone Detection:** Cross Zone Detection is part of the National Fire Code. In the case of cross-zone detection, single detector activation shall cause an alarm signal to be generated; second detector activation shall generate a pre-discharge signal and start the pre-discharge condition. No single detector sets off the entire fire suppression system.
- E. **Entrance Facility (EF):** An entrance to the building for both private and public network service cables including the entrance point at the building for telecommunications equipment that serves the occupants of a building. Equipment housed therein is considered distinct from a telecommunications room because of the nature of its complexity.
- F. **Horizontal Cross-connect (HC):** An intermediate distribution point used to connect horizontal cable and cabling subsystems or equipment.
- G. **HVAC:** Heating, Ventilation and Air-Conditioning
- H. **Main Cross-connect (MC):** A distribution point in which the building backbone cables terminate and at which connections to the wide-area network may be made.
- I. **Open Cable:** Cabling that is not run in a raceway as defined by NFPA 70. This refers to cabling that is "open" to the space in which the cable has been installed and is therefore exposed to the environmental conditions of that space.
- J. **Open Office:** A floor space division provided by furniture, moveable partitions, or other means instead of by building walls
- K. **Pathway:** A physical infrastructure utilized for the placement and routing of telecommunications cable.
- L. **TBB:** Telecommunications Bonding Backbone
- M. **TGB:** Telecommunications Grounding Bus-bar
- N. **TMGB:** Telecommunications Main Grounding Bus-bar
- O. **Telecommunications Room (TR):** An enclosed space for housing telecommunications equipment, cable, terminations, and cross-connects. The room is the recognized cross-connect between the backbone cable and the horizontal cabling.
- P. **Work Stations:** Defined as any place a person may work. This includes reception areas, conference rooms, lunch rooms, day rooms, copier rooms, printer rooms, etc.

6.0 DESIGN CRITERIA

- A. The Subcontractors shall accept direction through the Contractor with respect to performance of their contractual obligations. Subcontractor shall have a designated project representative and a back-up representative, either or both of whom shall attend all meetings, whether regularly scheduled or not.
- B. Subcontractor shall meet with members of local regulatory authorities, utility companies and municipal service boards to coordinate their requirements with the project design and installation.

- C. King County reserves the right to review and comment on the design documents. Their reviews shall be in the form of comments which shall be considered either as interpretations of the design or clarification of the intent of the scope of work. Respond to these review comments with written acceptance or rejection of each comment. King County or its technical representatives will not accept responsibility for the technical design of the project, which remains the responsibility of the design and construction team.
- D. Design team is required to carry, as Architect and Engineers of Record, professional liability insurance (errors and omissions), of sufficient policy value and acceptable deductible, to cover their acts as Architect and Engineer of Record for this project. Furnish evidence of professional liability insurance coverage to the Owner for review and acceptance. Minimum policy coverage shall be \$2,000,000.

7.0 SUBMITTALS

7.1 General

- A. Submit all design drawings, calculations, and shop drawings to the Owner for review and comment.
- B. King County shall be the sole judge of a submittal's completeness. Incorporate all required information into the submittal as directed.
- C. Documents shall be reviewed and stamped by Engineer of Record prior to submittal. By virtue of reviewing and commenting on such calculations and shop drawings, King County and its Representatives do not accept any responsibility for the accuracy or appropriateness of the calculations, since that responsibility rests solely with the Design and Construction Team.

7.2 Submittal Requirements

- A. For Schematic and Design Development phases, submit as indicated below by discipline in accordance with the following:
 - 1. Schematic Phase: As a minimum, a single line layout for at a scale not less than 1:100 (1/8 inch). Submit a complete double line layout of areas of critical importance, at a scale of 1:50 (1/4 inch) including equipment.
 - 2. Design Development: Submit minimum 1:100 (1/8 inch) scale floor plans, new and renovated, incorporating all of the revisions required by comments from schematics.

7.3 Disciplines

- A. Plumbing
 - 1. Narrative
 - a. Existing plumbing systems to be used and necessary modifications
 - b. New plumbing systems
 - c. New or modified water treatment

2. Floor Plans/Drawings
 - a. Room names
 - b. Identify
 - 1) Existing plumbing fixtures
 - 2) New plumbing fixtures
 - 3) Existing equipment
 - 4) New equipment
 - 5) Plumbing piping
 - c. Size of pipe
 - d. Equipment schedule
 - e. Fire & smoke partitions
 - f. Demolition plans
 - g. Riser diagrams
 - h. Legend, notes, and details
 3. Location and size of sprinkler riser, standpipes, and fire pumps (see fire protection)
 4. Location of emergency eyewash and shower equipment
 5. Calculations (equipment & piping)
 6. List of Required Contract Specifications
 7. Contract Specifications
- B. Sanitary
1. Narratives:
 - a. Existing sanitary systems: underground water, sanitary sewers, storm sewers, and fuel gas with sources, disposal methods, storage pressures, condition, etc.
 - b. New sanitary systems
 - c. Provide water analysis & expected yield if well required
 - d. Circulation study to assess emergency vehicle access
 2. Utility Plans/Drawings showing existing and new sanitary systems:
 - a. Size of pipes
 - b. Invert elevations of sewers
 - c. Locate/size
 - 1) Pumps

- 2) Storage facilities
- 3) Treatment equipment
- 4) Fire hydrants
- 5) Sectional and post indicator valves
- 6) Backflow preventer
- d. Profiles of sanitary & storm sewers
- e. Demolition Plans
- f. Legend, notes, and details
3. Point of connection to sprinkler system
4. Calculations
5. List of specifications
6. Contract Specifications

C. HVAC:

1. Description of HVAC systems
2. Equipment for each functional space
3. Location/sizes:
 - a. Mechanical equipment room
 - b. Principal vertical shafts
4. Block layout of equipment
5. Louvers:
 - a. Outside air
 - b. Exhaust air
 - c. Relief air
6. Engineering calculations³
7. Selection of HVAC equipment
8. Catalog cuts of equipment
9. Room by room heating and cooling loads
10. Zone by zone heating & cooling loads
11. Building block heating & cooling loads

12. Psychometric chart for air handling unit
13. Coil entering and leaving conditions
14. Fan motor heat gains
15. Consumption of humidification loads
16. Sound/acoustic analysis
17. Room-by-room air balance charts⁴
18. Chilled water plant:⁵
 - a. Quantity and type of chillers
 - b. Capacity in tons of refrigeration
 - c. Electrical equipment
19. Heating system:
 - a. Total heating load
 - b. Domestic hot water load
 - c. Humidification load
 - d. Equipment steam demand
 - e. Zoning of heating system
20. HVAC floor plan: ⁶
 - a. Main supply, return and exhaust ductwork
21. HVAC
 - a. Volume dampers
 - b. Fire and smoke partitions
 - c. Fire and smoke dampers
 - d. Smoke detectors
 - e. Automatic control dampers
 - f. Air quantities for each room
 - g. Air inlets/outlets
 - h. Rises and drops in ductwork
 - i. Expansion loops
 - j. Anchors
 - k. Valves

- I. Drip assemblies
 - m. Balancing fittings
22. Interconnection of HVAC equipment with fire protection equipment (see fire protection)
23. Plan/section of mechanical equipment rooms
24. Schematic flow and riser diagrams⁷
25. Schematic control diagrams⁸
26. HVAC demolition drawings
27. Phasing plan
28. Equipment schedule
29. Seismic bracing
30. Symbols and abbreviation
31. Selection of:
 - a. Pumps
 - b. Fans
32. Sizing and selection of
 - a. Expansion tanks
 - b. Heat exchangers
33. Sound analysis
34. Complete selection data
35. Outside chilled water and condenser water distribution⁹
36. Standard detail drawings
37. Automatic temperature control drawings¹⁰
38. HVAC specifications

Submittal Footnotes:

¹ Provide specific design recommendations and full back-up data. Include the heating and cooling capacities of each functional area and the block cooling and heating loads for each new and/or existing building.

² The locations of these louvers must not allow short circuiting of air from emergency generator exhaust or truck waiting and loading dock areas into air intake etc. Consider factors affecting

louver location such as visibility, historical considerations, wind direction, nuisance and health hazard odors (from emergency generator or truck exhausts).

³ Include room-by-room, peak zone-by-zone, and building block heating and cooling loads. Provide a tabulation of steam consumption based on data from all sources. Show correlation between each HVAC zone boundary and architectural floor area correlation between the architectural room numbers and abbreviated/coded room numbers used with computer input data sheets.

⁴ Show supply, return, exhaust, make-up, and transfer quantities with intended pressure relationships, i.e. positive, negative, or zero with respect to adjoining spaces.

⁵ Provide pertinent data on accessories such as pumps and cooling tower etc. Show the extent of the outside chilled water and condenser water piping. Clearly show how the piping will be laid in tunnels, trenches, or by direct burial.

⁶ Show ceiling clearances, at locations where ducts cross each other, by providing 1:50 (1/4 inch) scale local sections. Show all ductwork, and piping 150 mm (6 inch) and larger in double line. Show separate floor plans for air distribution and piping unless waived by THE OWNER. Show clearances required for access and maintenance with coil and tube pull.

⁷ Show typical air handling systems and all hydronic systems with existing capacities and new estimated loads. Verify actual operating conditions and capacities of HVAC systems prior to design.

⁸ Show control devices, such as, thermostats, humidistats, flow control valves, dampers, freezestats, operating and high limit sensors for all air systems and fluids, smoke dampers, duct detectors etc. Provide a written description of the sequence of operation on the floor plans. Detail the scope of work involved with the Central Engineering Center (ECC) and address if enough spare capacity is available or a new ECC is required. Show a point schedule for analog/digital input/output to be included in ECC.

⁹ Show pipe sizes and insulation with plans, profile, sections, details, and all accessories, such as, anchors, expansion loops/joints, valves, manholes, capped and flanged connections, interface between the new and existing work (if any). Clearly indicate interferences (if any) with the existing utilities and/or landscape elements on outside piping layout drawings. Show rerouting any utilities, cuttings of roads, pavements, trees, etc., and the extent of new and demolition work. Outside utility drawings shall be based on the study of the latest site drawings, discussions with engineering personnel, and actual site inspection of the existing utility.

¹⁰ Show all duct detectors, control valves/dampers static pressure sensors, differential pressure control assemblies, etc., whose actual physical location is critical for the intended sequence of operation on floor plans.

D. Fire Protection

1. Narrative: ¹
 - a. Fire and smoke separation
 - b. Fire sprinkler/standpipe system
 - c. Water supply available/max. demand
 - d. Water flow testing results

2. Fire alarm systems²
 - a. Existing to be modernized
 - b. Base loop system for interface of new construction
 - c. Size of air handling units
 - d. Exit paths from each zone
 - e. Distances to stairs
 - f. Occupancy of each area
 - g. Exit calculations for each floor
 - h. Smoke control features
3. Floor Plans/Drawings:³
 - a. Sprinkler zones
 - b. Fire alarm zones
 - c. Smoke zones
 - d. Building water supply
 - e. Interior sprinkler supply lines
 - f. Standpipes
 - g. Fire extinguisher cabinets
 - h. Fireproofing of structural members
 - i. Sprinkler/standpipe riser supply piping
 - j. Termination of sprinkler main and inspector test drains
 - k. Sprinkler alarm valves
 - l. Waterflow and tamper switches
 - m. Sprinkler system fire department connections
 - n. Sprinkler design hazards per NFPA 13
 - o. Exit signs and emergency lighting
 - p. Occupied areas not protected by automatic sprinklers
4. Calculations
 - a. Estimated capacities for proposed air handling units in cubic meters (cubic feet) per minute
5. Location of
 - a. Fire alarm system
 - b. Annunciator panels
 - c. Pull stations

- d. Flow switches
 - e. Audio-visual devices
 - f. Smoke detectors
 - g. Duct smoke detectors
 - h. Smoke dampers
 - i. Fire dampers
 - j. Fire alarm risers⁴
 - k. Exit signs
 - l. Emergency lighting
 - m. Fire sprinklers
 - n. Standpipes
 - o. Fire hydrants
 - p. Fire pumps
 - q. Post indicator valves
 - r. Sectional valves
 - s. Fire extinguisher cabinets
 - t. Electromagnetic door hold open devices
 - u. Wall sections indicating fire resistive ratings
 - v. Door and window schedule with fire rating or fire rated glazing
 - w. Zoning of each fire alarm initiating device
6. Details:
- a. Fire pump system (capacity and pressure)
 - b. Elevation and isometric view of fire pump
 - c. Stairwell sign
 - d. Annunciator panel
 - e. Interconnection of fire alarm system with:
 - f. Smoke dampers
 - g. Air handlers
 - h. Elevator controls
 - i. Kitchen fire extinguishing and fire pump system
 - j. HVAC system with smoke duct detectors
7. Single line riser diagram for fire alarm system
8. Height/configuration of storage racks and shelving

9. Specifications
10. Corresponding data for FM200 System

Fire Protection Submittal Footnotes:

¹ Indicate NFPA 220 and UBC fire resistive rating of the building, NFPA 101 occupancy type, and fire protection code analysis to access compliance with NFPA 101.

² Determine type, features, age, reliability, compliance with present day codes, capacity, zoning, supervision, control panel and power supplies, initiating devices and circuits, and auxiliary functions for existing fire alarm system. Indicate manufacturer, model number, voltage, and wiring style of existing alarm systems and devices. Provide recommendations for the proposed fire alarm work.

³ At submission, include room names, room numbers, door locations and swings, smoke and fire rated partitions, sprinkler/standpipe risers to floor plans. Add location of all valves (post indicator, sectional) and backflow preventer if provided.

⁴ Show new equipment and/or the necessary changes involved if modification to the existing system is required. Include any recommendations where certain requirements of the design criteria might be waived in order to allow the existing equipment to be reused.

E. Electrical

1. Design Narrative
2. Location and size of:
 - a. Electrical equipment
 - b. Electrical closets
 - c. Telephone closets
3. Drawings:
 - a. Include wiring diagrams and installation details of equipment indicating proposed location, layout and arrangement, control panels, accessories, piping, ductwork, and other items that must be shown to ensure a coordinated installation.
 - b. Wiring diagrams shall identify circuit terminals and indicate the internal wiring for each item of equipment and the interconnection between each item of equipment. Drawings shall indicate adequate clearance for operation, maintenance, and replacement of operating equipment devices.
 - c. Submit drawings for:
 - 1) Communications systems
 - 2) Proposed electrical system⁴
4. List of drawing symbols
5. List of specialty areas

6. Method of short-circuit calculations
7. Method of voltage drop and demand calculations
8. Load calculations for normal and emergency use

F. Product Data

1. Panelboards
2. Transformers
3. Cable trays
4. Wireways
5. Receptacles
6. Circuit breakers
7. Switches
8. Transformers
9. Enclosed circuit breakers
10. Motor controllers
11. Manual motor starters
12. Combination motor controllers
13. Telecommunications Grounding Busbar
14. Surge protective devices

7.4 **Equipment**

- A. Equipment (on architectural drawing)
- B. Activation Equipment List (Excel format)
- C. Specifications

7.5 **Specifications**

- A. Submit for all technical disciplines the original CSI Master Specification section drafts marked-up with pencil showing the editing for the project. Clearly identify modifications, deletions and insertions. Assure the specification drafts have been edited and tailored in their application to represent accurate coordination between disciplines.

- B. Type specifications in final format and content including any desk copy changes made at the previous review. Submit a complete set of the typed specifications for review. Include one set of full size final drawings of all disciplines, fully coordinated.
- C. Return all draft specifications reviewed to aid the final bid document review. These draft specifications will later be returned.

8.0 CONSTRUCTION DOCUMENTS PHASE

8.1 Construction Document Submittals:

- A. Submit fully dimensioned, complete, and coordinated 1:100 (1/8 inch) scale floor plans, incorporating all revisions required by comments from previous phases. Submit legend, notes, and details at a scale not less than 1:100 (1/8 inch).
- B. Construction documents shall consist of coordinated drawings and specifications signed and sealed by a Professional Engineer registered in the State of Washington ready for permit submission to the authorities having jurisdiction; containing, as a minimum, the following:

8.2 Mechanical

- A. Include the following for each submittal:
 - 1. Heating, cooling and ventilation calculations for server rooms, office space, NOC, mainframe, printers, telecommunication room, lobbies, sprinkler room, MDF, IDF rooms, etc.
 - 2. Equipment schedules defining performance characteristics of all items of equipment. Rotating equipment, such as fans and pumps, shall include efficiencies, brake horsepower and motor sizes.
 - 3. Riser diagrams for plumbing systems showing all locations and areas served.
 - 4. HVAC, plumbing, and fire protection plans, 1/8" scale. Systems distribution and equipment location shall be shown for each floor. Ductwork over 18" shall be shown double line. Number drawings to easily correlate to architectural numbering system; coordinate with architectural drawing list. Plans shall show coordination with all other construction trades.
 - 5. Miscellaneous details and large-scale plans and sections necessary to show coordination in congested areas.
 - 6. Site plans showing extent of contract, work and point of interface with site utilities work.
 - 7. Complete specifications defining a scope of work, equipment items, materials, and means and methods of installation. All drawings and specifications shall be prepared in the format designated by the Contractor.
 - 8. Equipment submittals for all mechanical equipment intended for use on the project (e.g. CRACs, fans, pumps, heaters, etc.) with manufacturer's installation instructions and proposed operating conditions (e.g. fan curves).

9. Documentation suitable for building department approval demonstrating envelope compliance with Washington State Energy Code (with Seattle Energy Code) may be prepared by an Energy Code Compliance Consultant. Obtain a copy of this document from the Architect.

8.3 Electrical

- A. Submittals shall include performance and characteristic curves.
- B. Submit coordination data for overcurrent protective devices.
- C. Submit testing procedures for:
 1. 600-volt wiring test
 2. Grounding system test
 3. Transformer tests
 4. Ground-fault tests
- D. Submit Manufacturers Shop Drawings for:
 1. Panelboards
 2. Transformers
 3. Cable trays
 4. Wireways
- E. Submit Manufacturers Product Data for:
 1. Receptacles
 2. Circuit breakers
 3. Switches
 4. Transformers
 5. Enclosed circuit breakers
 6. Motor controllers
 7. Manual motor starters
 8. Combination motor controllers

9. Telecommunications Grounding Busbar
10. Surge protective devices

9.0 COORDINATION

- A. Transmit to other trades, via the Contractor, all information required for work to be provided under this Section in ample time for installation.
- B. Wherever work interconnects with work of other trades, coordinate with these trades to insure that all trades have the necessary information to properly install all connections and equipment.
- C. Provide required supports and hangers for major items of piping and equipment, so that loading will not exceed allowable loadings of structure. Submit equipment weights and loadings, including method of attachment, to the Contractor for review.
- D. Coordinate and schedule work with all trades and the construction sequence. Install and coordinate the mechanical work in cooperation with other trades installing interrelated work. Before installation, take proper provisions to avoid interferences in a manner reviewed by the Contractor. All changes required in the work of the Subcontractor, caused by their neglect to do so, shall be made by them at their own expense.
- E. Required anchor bolts, sleeves, inserts and supports shall be furnished by the Subcontractor as necessary for equipment provided by Subcontractor. Such anchor bolts, sleeves, inserts and supports shall be installed, except as otherwise agreed to, by the trade furnishing and installing them. Location of anchor bolts, sleeves, inserts and supports shall be coordinated by the Subcontractor requiring them to insure that they are properly installed. Any expense resulting from the improper location of anchor bolts, sleeves, inserts and supports shall be paid for by the Subcontractor with the responsibility for directing their proper locations.
- F. Adjust location of pipes, equipment, ducts, etc. to accommodate the work and to prevent interferences, both anticipated and encountered. Determine the exact route and location of each pipe and duct prior to fabrication. Right of Way: Lines which pitch shall have the right of way over those which do not pitch. For example, plumbing drains normally have right of way. Lines whose elevations cannot be changed shall have right of way over lines whose elevations can be changed. Make offsets, bends and changes in direction of pipes and ducts as required to maintain proper head room and pitch of sloping lines whether or not indicated on the Drawings.
- G. Install all mechanical work to permit removal (without damage to other parts) of compressors, filters, fan shafts and wheels, belt guards, sheaves and drives and all other parts requiring periodic replacement or maintenance. Provide manufacturer's recommended clearances around equipment for service and proper operation.
- H. Provide access panels in equipment, ducts, etc., as required for inspection of equipment and for proper maintenance.

10.0 MATERIAL REQUIREMENTS

- A. If products and materials for specific items or systems are specified, use those specified as representative of quality desired. If products and materials are not specified, use first-class high quality products and materials subject to review and acceptance by the Architect and Owner.

- B. All products and materials shall be new, clean, free of defects and free of damage and corrosion.
- C. Ship and store all products and materials in a manner which will protect them from damage, weather and entry of debris. If items are damaged in the opinion of the Architect, Owner's Representatives, or Contractor do not install, but take immediate steps to obtain replacement or repair.

11.0 INSTALLATION

- A. The Subcontractor shall prepare shop-drawing submittals in accordance with submittal schedule. These submittals shall be reviewed and stamped by the Engineer of Record. Shop drawings shall show compliance with the Construction documents, coordination with all construction disciplines, accuracy of technical and dimensional data, and of the proposed manufacturer.
- B. Attend regularly scheduled construction coordination meetings and other meetings, as requested by Contractor. Members of the Subcontractor's staff, who have direct knowledge of the mechanical design, shall accompany their respective installation counterparts at these meetings.
- C. The Engineer of Record shall perform periodic site observations, on an average of twice per month basis, and prepare a status of installation report including deficiencies with respect to the contract documents. These site observations shall be performed in the presence of the Architect and/or the Owner's representatives, at their discretion.
- D. Provide a written description of all observed field coordination problems, along with proposed resolutions, to the Contractor for distribution.
- E. The Architect and the owner may perform additional periodic observations, which may generate deficiency comments. Respond to these published deficiency lists within a one-week period.
- F. The Engineer of Record shall perform final punch list inspections and submit to the Contractor.
- G. Perform all system tests required by regulatory or code agencies in the presence of the appropriate local authorities, the contractor and the Owner.

12.0 OWNER ACCEPTANCE REQUIREMENTS

- A. Identify equipment with permanent nameplates that agree with subcontractor furnished as-built drawings.
- B. After completion of work and prior to final acceptance, thoroughly clean all parts of the work, remove all debris and surplus equipment and leave installation in perfect condition, ready for use.
- C. Operational and Maintenance Manuals.
 - 1. Maintenance manuals shall be provided to the Owner (minimum of three (3) copies) in three-ring binders, labeled and tabbed, consisting of the following as minimum requirements.
 - a. Manufacturer's literature on all items of equipment.
 - b. Operating and maintenance instructions.

- c. Sequence of operation, wiring, and control diagrams.
- D. Commissioning: Commission all mechanical and electrical systems at the presence of King County's representative. Provide detailed commissioning plan prior to start of TAB and commissioning work for review and approval by King County. Provide 2 week notice in advance of all commissioning and testing activities.

13.0 RECORD DOCUMENTS

- A. Deviations: Subcontractor to maintain record drawings of changes to mechanical systems, including locations, sizes, or arrangement. Record drawings to be used by the subcontractor to produce As-Built Drawings.
- B. Location of Concealed Work: Locate accurately to scale and dimension from column lines, concealed piping and ductwork.
- C. At end of construction furnish owner with an "as-built" set of reproducibles and electronic disk based on AutoCAD 2006 software.

14.0 WARRANTY

- A. Submit a single guarantee stating that all portions of the work are in accordance with Contract requirements. Guarantee all work against faulty and improper material and workmanship for a period of one (1) year from date identified in invitation to bid. Within 24 hours after notification, correct any deficiencies that occur during the guarantee period at no additional cost to the Owner, all to the satisfaction of the Owner. Obtain similar guarantees from subcontractors, manufacturers, suppliers and sub trade-specialists.
- B. Be responsible for leaks in pipes during Guarantee Period. Repair such leaks, at no cost to Owner, within 24 hours of notice by the Owner. Repair leaks which occur prior to the completion of this Subcontract at once. Be responsible for any damage caused by such leaks and repair thereof and reimburse Owner for expenses incurred. The subcontractor shall indemnify the owner, the Architect and Contractor against loss liability, damage or expense, including reasonable attorney's fees, in connection with any claim resulting from such leaks, which may be asserted by any other third party. Owner reserves the right to contract with others for remedy of guarantee deficiencies and invoice Sub-contractor for such work.
- C. Fire stop and seal wall and floor penetrations and penetrations with materials that provide the same fire rating as the floor or wall. Provide fire dampers or combination fire/smoke dampers, as required.
- D. The Subcontractor shall provide adequate means for and shall fully protect finish parts of the materials and equipment against damage from whatever cause during the progress of the work until final acceptance. Materials and equipment shall be covered in such a manner that no finished surfaces will be damaged or marred, and all moving parts shall be kept perfectly clean and dry.
- E. At conclusion of each day's work, clean up and stockpile on site all rubbish, debris and trash accumulated during the day because of work of this Section. Sidewalks and street adjoining the property shall be kept broom clean and free of debris, rubbish, trash, and obstructions of any kind caused by work of this section, which will affect the conditions of streets, walks, utilities and property.

END OF GENERAL

ARCHITECTURAL GENERAL

1.0 SCOPE

- A. The following information describes general architectural tenant improvements for the relocation and consolidation of a Data Center for King County. The project scope includes data equipment areas, technical support spaces, staff and administrative areas and storage. Space requirements and adjacencies apply generally to all sites under consideration for design and construction of the Center. For purposes of illustration, space sizes and adjacencies are illustrated with the drawing titled "Test Fit, Fisher Plaza, 4th Floor", dated February 15, 2007.
- B. Codes and References:
 - 1. International Building Code or Seattle Building Code as determined by project location and jurisdiction, 2003/2006 edition as applicable at date of submittal.
 - 2. Accessible and Useable Buildings and Facilities ANSI Standard A117.1, 2003 edition.
 - 3. Construction requirements as defined by the Telecommunications Industry Association (TIA) Standard for Data Centers. King County has identified this project as a Tier 3 center.
- C. Submittals: During design and contract document preparation provide King County project representative with the following information:
 - 1. Technical specifications and material color and finish samples for interior material selections in both General Office and Computer Center construction levels.
 - 2. Design calculations and structural analysis of existing floor and ceiling construction indicating that existing structural systems are capable of supporting required equipment and supply storage loads in Equipment Areas, UPS, Storage Areas and as required by the specific site under consideration. Load information will be provided to the Design Team by King County. Analysis will consider vertical and lateral loads.
 - 3. Provide details of the Architectural and Structural elements required for TIA Tier 3 construction identified as applicable by King County, including:
 - a. Equipment Room/Main Frame Floor Loading: Minimum distributed floor loading capacity recommended by TIA-942 Tier 3: 250 lb/sf.
 - b. Hanging capacity: 50 lb/sf
 - c. Humidity Control: Vapor barriers to be installed the perimeter walls and ceiling of equipment areas to support equipment humidification limits, as identified in Final Design.
 - d. Security Walls: Full height construction as defined, floor to underside of structural deck. Where HVAC or other building systems requirements dictate, provide permeable construction above finish ceiling.
 - e. Other specific requirements are identified elsewhere in this document.

2.0 GENERAL PROGRAM SPACE REQUIREMENT MATRIX

A.	Function/Activity	Size (sf) Test Fit Model	Primary Adjacency	Secondary Adjacency	Construction Requirements	Security Partitions
1.	Equipment Room/ Main Frame	6,383	Command Center	Equipment Room	Computer Ctr ↓	yes
2.	Printers	640	Command Center	Paper Storage		no
3.	Paper and Supply Storage	560	Command Center	Public Corridor		At demising walls
4.	Tape Storage	350	Command Center	Main Frame		At demising walls
5.	MDF Room	350	Equipment Room	N/A		At demising walls
6.	UPS System	295	Equipment Room	N/A		At demising walls
7.	Storage and Staging	600	Equipment Room	Public Corridor		yes
8.	Command Center	648	Equipment Room	Printers / Main frame		no
9.	Network Operations Center	included above	n/a	N/A		no
10.	Access Control	342	Public Corridor		general office ↓	At demising walls
	Administrative spaces	2,328				
11.	Production Support	included above	General Admin.			N/A
12.	Production Engineering	included above	General Admin.			N/A
13.	Production Control	included above	Separate (quiet)	Command Center		N/A
14.	Managers	included above	General Admin.	Break Room		N/A
15.	Call Center (Help Desk/Service Desk)	included above	Separate (noise)			N/A
16.	Incident Response Team	250	Managers			N/A
17.	Break Room	240	General Access			N/A
18.	Storage/Office Supplies	338	General Access			N/A
19.	Staff Lockers	42	General Access		N/A	

3.0 CONSTRUCTION REQUIREMENTS

- A. Computer Center: Materials, systems, finishes and details required by King County and TIA Standards for construction of an environment appropriate for continued safe maintenance of data center systems and support equipment. Dust and humidity control, control of static electricity, security, noise and light reflectance are of primary importance.
- B. General Office: Materials, systems, finishes and details generally acceptable for a commercial office environment. Normally acceptable levels of noise control, light reflectance, performance and durability are expected and may permit use of the site's standard materials and finishes, as acceptable to King County.

4.0 ADJACENCIES

- A. Primary: Requiring immediate adjacency
 - 1. Entry to Equipment Room- must gain access through Command Center with observation by Data Center staff at all times.
 - 2. Public Corridor System to Access Control.
 - 3. Equipment Room (principal server area) to Command Center. Provide access and full vision of servers and equipment from Command Center.
 - 4. Network Operations Center and Command Center are combined.
 - 5. Main Frame to Command Center. Provide access and full vision of equipment from Command Center.
 - 6. Printers to Command Center and Equipment Areas. Provide direct access. Printers must be separated from dust sensitive Equipment Areas by dust-proof partitions that do not preclude full vision of printers from Command Center.
 - 7. MDF Room to Equipment Area.
 - 8. Paper Storage to Printer Area.
- B. Secondary: Requiring convenient access, but not immediate adjacency
 - 1. Tape Storage to Command Center. Command Center staff routinely access and run tapes from this library.
 - 2. UPS to Equipment Areas. Minimize power runs. Equipment Storage and Staging. Convenient, secure access to Equipment Areas is valuable.
 - 3. Offices and Administrative Areas to Command Center. Convenient communication and access to and from Command Center without leaving secure perimeter.

5.0 PRINCIPAL SPACE REQUIREMENTS

A. Command Center

1. Staffing: (3) operators per shift with 3 shifts that overlap by 2 hours requires (6) workstations, located for observation of equipment and printer areas.

(9) total operators will work in the Center, all shifts
(1) supervisor workstation will be shared by (3) supervisors over the (3) shifts.
2. Responsibilities: Mainframe operations

Tape management
Printer operation
Call center for after hours help desk and NOC calls
3. Furnishings and equipment: (6) shared console spaces for operators
(1) shared systems workstation for supervisor
(12) individual lockers located in common locker area.
4. Adjacencies: Access control to equipment areas.

Direct connection to equipment areas (servers and main frames), printers.
Convenient access to tape storage.
Convenient to Production Control Staff.
Combined with NOC.
5. Environment: Acoustical treatment to control noise level in space when several operators and staff are working together.

Construction required to minimize noise penetration from adjacent spaces.
Lighting to minimize glare on monitors.
Construction Level: Computer center
6. Narrative: There are 9 Data Center operators and 3 shift supervisors that work 3 shifts per day, 24x7x365; typically there are 3 staff per shift on weekdays, and 2 per shift weekends. Operators do not have their own cubicles but sit in the Command Center and have lockers for personal belongings. They perform mainframe operations, tape management and attend the high speed printers for report printing and distribution. They also are the call center for after-hours Help Desk and NOC calls for 300+ sites. Shifts overlap by up to 2 hours, so staff from both shifts are in the Command Center at that time. Systems technical support staff are often in the Command Center while troubleshooting or training operators on new procedures. One cubicle is required for supervisor workspace, for working on timesheets and other tasks.

B. Network Operations Center (NOC)

1. Staffing: (2) operators, day shift only
2. Responsibilities: Receive telephone and e-mail calls from system users and satellite locations.
3. Furnishings and equipment: (2) shared console spaces for operators
Multiple screens and displays require black out background. The operators share up to (6) computer terminals requiring appropriate console space.
(2) individual lockers located in common locker area.
4. Adjacencies: Combined with Control Center for ease of communication.
5. Environment: Acoustical control to reduce noise level in space and minimize noise penetration from adjacent spaces.
Lighting that minimizes glare on monitors, focusing light on work consoles to allow clear viewing of larger, shared screens.
Construction Level: Computer center
6. Narrative: There are currently 2 NOC staff; the NOC is currently staffed who provide after hours Help Desk and NOC (KCWAN and I-Net) call support during daytime hours. Calls are forwarded to the Command Center Operators after hours.

C. Access Control

1. Staffing: (1) staff person daytime only
2. Responsibilities: Control entry to data center for visitors, staff and some deliveries. Message center and administrative support for data center staff. Waiting area for visitors.
3. Furnishings and equipment: (1) 10' x 12' reception desk/workstation. Custom casework and or systems furnishings as appropriate to final design.
(3 or 4) chairs for waiting area.
(1) individual lockers located in common locker area.
4. Adjacencies: Directly inside main entry doors to Data Center. Control point to administrative areas.
5. Environment: Normal office lighting and acoustical environment.
Construction Level: General Office.
6. Narrative: During normal office hours all visitors are visually identified and electronically admitted to the Center from this desk.

D. Production Support Services

1. Staffing: (6) staff, day shift only
2. Responsibilities: Support change and configuration management, documentation, drawings procedures, websites, that support production networks, systems and applications.
3. Furnishings and equipment: (6) ORIM standard workstations, 7' x 8'
(6) individual lockers located in common locker area.
4. Adjacencies: Part of the shared office/administration area, convenient to Production Control and Production Engineering.
5. Environment: Normal office lighting and acoustical environment. Construction level: General office.

E. Data Center Management

1. Staffing: (3) staff, day shift only
2. Responsibilities: Overall management oversight of OIRM activities: Operations Manager
Production Support Services Manager
Help Desk/NOC Manager
3. Furnishings and equipment: (3) ORIM standard management workstations, 10' x12'
include informal conferencing surface
(1) each 30" high x 42" lateral file, locking.
(2) each side chairs
(3) total individual lockers located in common locker area.
4. Adjacencies: Locate managers together, acoustically separated from other administrative area staff members in open office environment.
5. Environment: Normal office lighting and acoustical environment.
6. Construction level: General office.

F. Production Engineering

1. Staffing: (1) staff, day shift only + (up to 8) 'hoteling' workstations
2. Responsibilities: Full time data center facility engineer supports the data center. In addition, up to (8) 'hoteling' cubicles are required for OIRM and other agencies' IT support staff and

vendors that need to troubleshoot, install or work on systems and network equipment in the data center.

3. Furnishings and equipment: (1) ORIM standard workstations, 7' x 8'
(8) carrel style workstations, 5' x 5'
(1) 30" high x 42" lateral file, locking.
(1) individual locker located in common locker area.
4. Adjacencies: Part of the shared office/administration area, convenient to Production Control and other Administrative staff.
5. Environment: Normal office lighting and acoustical environment.
Construction level: General office.

G. Production Control

1. Staffing: (3) staff, day shift only
2. Responsibilities: Main frame Staging, scheduling, security and report management.

Interaction with the Command Center operators on mainframe operations.
3. Furnishings and equipment: (3) ORIM standard workstations, 7' x 8'
(1) 30" high x 42" lateral files, locking, to store mainframe security records, microfiche and report processing.
(3) individual lockers located in common locker area.
4. Adjacencies: Part of the shared office/administration area, convenient to Control Center.
5. Environment: This group works as a team and requires a quiet environment separated to extent possible from other office activities. Normal office lighting and acoustical environment.
6. Construction level: General office.

H. Call Center (Help Desk/Service Desk)

1. Staffing: (4) staff, day shift only
2. Responsibilities: Mainframe staging, scheduling, security and report management. Interaction with the Command Center operators on mainframe operations.

3. Furnishings and equipment: (6) station call center workstations, 5' x 5' each
(4) individual lockers located in common locker area.
4. Adjacencies: Part of the shared office/administration area, but acoustically isolated within open office environment to facilitate phone conversations and minimize cross-talk between help desk staff.
5. Environment: Acoustical absorption required to reduce sound transfer to adjacent areas.
6. Construction level: General office.

I. Paper and Supply Storage

1. Capacity: Provide storage for (10) 36" x 48" pallets weighing 2,000lbs each (166 lb/sf).
2. Furnishings and equipment: (6 to 10) steel shelving units
3. Note: Provide 3/4 in x 4 ft fire treated plywood wainscot, all walls.

6.0 FINISH SCHEDULE

A. FUNCTION/ACTIVITY	FLOOR/FINISH	CEILING	WALL TYPE
1. Equipment Room/Main Frame	Access floor 1 / vinyl	SAC 1	1 hour / secure / vapor barrier
2. Printers	Access floor 1 / vinyl	SAC 2	1 hour / STC 35
3. Paper and Supply Storage	Access floor 2 / vinyl	SAC 2	Bldg. standard
4. Tape Storage	Access floor 1 / vinyl	SAC 1	1 hour / secure / vapor barrier
5. MDF Room	Access floor 1 / vinyl	SAC 1	1 hour / secure / vapor barrier
6. UPS System	Access floor 1 / vinyl	SAC 1	1 hour / secure
7. Storage and Staging	Access floor 1 / rubber	SAC 2	1 hour / secure
8. Command Center	Access floor 1 / vinyl	SAC 1	1 hour / STC 35
9. Network Operations Center	Access floor 1 / vinyl	SAC 1	1 hour / STC 35
10. Access Control	Access floor 2 / carp tile	SAC 2	Bldg. standard
11. Production Support Services	Access floor 2 / carp tile	SAC 2	Bldg. standard
12. Production Engineering	Access floor 2 / carp tile	SAC 2	Bldg. standard
13. Production Control	Access floor 2 / carp tile	SAC 2	Bldg. standard
14. Managers	Access floor 2 / carp tile	SAC 2	Bldg. standard
15. Call Center (Help Desk / Service Desk)	Access floor 2 / carp tile	SAC 2	Bldg. standard

A.	FUNCTION/ACTIVITY	FLOOR/FINISH	CEILING	WALL TYPE
16.	Incident Response Team Room	Access floor 2 / carp tile	SAC 2	Bldg. standard / STC 35
17.	Break Room	Access floor 2 / rubber	SAC 2	Bldg. standard / STC 35
18.	Storage / Office Supplies	Access floor 2 / carp tile	SAC 2	Bldg. standard
19.	Staff Lockers	Access floor 2 / carp tile	SAC 2	Bldg. standard

7.0 GENERAL MATERIALS AND CONSTRUCTION:

- A. Materials in Computer Center Areas: As defined by TIA Tier 3 guidelines and as follows:
1. Interior Partitions: Building Standard 1 hour light gauge metal framing with GWB each side. Install vapor barrier under GWB at interior space.
 2. Security Partitions with vapor barrier:
 3. In all Tenant areas bordering building common and service spaces or other tenant areas partitions will extend full height to underside of floor structure above, and tightly fitted around structural members, ductwork and other penetrations.
Where HVAC systems or other considerations preclude full height partitions, provide 1-1/2" square mesh .225" wire cloth closure, attached with tek screws at 6" centers to track and underside of ceiling structure.
 4. Partition Components:
 - a. Framing: 3-5/8 inch deep, or as required to meet design requirements; ASTM C 645 with manufacturer's standard corrosion-resistant zinc coating.
 - b. Deflection Track: 2-inch deep flanges at connections to structural deck and as required by building shell construction.
 5. Sheet Blocking: 0.027 inch thick steel sheet.
 6. Security board: 5/8" Fire resistant plywood fastened to framing under GWB at equipment room perimeters.
 7. Gypsum Wallboard: ASTM C36. 5/8 inch Type X, tapered edges.
 8. Finish: Level 4; satin and semi-gloss paint finishes.
 9. STC-Rated Assemblies: Seal construction at perimeters, behind control and expansion joints, and at openings and penetrations with a continuous bead of acoustical sealant. Install acoustical sealant at both faces of partitions at perimeters and through penetrations.
 10. Sound Attenuation Blankets: ASTM C 665, Type I, glass, slag wool, or rock wool. 3 inch thick between studs, and 48 inch wide, 3 inch thick continuous loose-lay batt centered over partitions and ceiling tile at perimeter of space.
 11. Access Flooring 1: At areas where floor loading and movement of materials require, replace the existing raised access flooring with new Tier 3 compliant system.
New Access Floor System to consist of modular and removable cementitious filled welded steel panels supported on all four edges by structural steel members which bolt onto adjustable height pedestal assemblies forming a modular grid pattern. Existing

support structure is acceptable for reuse if required specifications are met.

- a. Floor Height: 18 inches, match existing raised flooring system.
 - b. Pedestals: Axial Load: 5000 lb. axial load without permanent deformation.
 - c. Overturning Moment: 1000 in-lbs.
 - d. Stringers: Concentrated Load: 450 lbs./sq. in. placed in the mid-span stringer center
 - e. Floor Panels: Concentrated Load: 1000 lbs./sq. in. at any location on the panel with a maximum top surface deflection of 0.100 inches.
 - f. Uniform Load: 250 lbs./sq. ft.
 - g. Ultimate Load: Minimum concentrated load of 3000 lbs. applied onto a one square inch area at any location on the panel without failure.
 - h. Impact Load: 150 lbs. dropped from a height of 36 inches onto a one square inch area
 - i. Flammability: Class A in accordance with ASTM-E84-1998.
 - j. Combustibility: Noncombustible per ASTM E 136.
 - k. Finish: 1/8 inch Static Dissapative Vinyl
 - l. Anti-Static Protection: 1,000,000 ohms (1.0×10^6) to 20,000 megaohms (2.0×10^{10} ohms), per NFPA 99 Chapter 3; and in conformance with IEC 61000-4-2.
12. Resilient Static Control Flooring: Rubber Tile, Noraplan duo el, Article 270
- | | |
|------------------------|--|
| Type: | ESD control, electrically conductive |
| Finish: | Smooth surface |
| Size: | 24 inches by 24 inches, 2.5 mm (0.10 inches) |
| Conductivity Warranty: | 5 year wear; 10 year conductivity. |
13. Resilient Base: 6-inch resilient base at all walls.
14. Suspended Ceiling Systems (SAC 1):
- a. Tile: Armstrong Clean Room Mylar type 1716, or approved square edge tile, 24 in. x 24 in. x 15/16 in. thick; color: White; NRC .55; Light reflectance 79%; Class A Flame spread.
 - b. Ceiling Suspension System: Prelude XL exposed tee. Seismically brace per IBC/SBC requirements.
15. Access Control and Security Systems: Provide hardware and construction to accommodate access and security control at all doors leading to Tenant areas from building common areas. Systems will include card access and/or biometric readers and other equipment as identified by King County.

Security Doors: Solid Core wood or metal doors with Hollow Metal frames, grouted solid. Non-removable pin hinges where door swings out into public space. Install 180 degree security viewers on all such doors.

B. Materials in General Office Areas:

1. Interior Partitions:
2. Provide building standard GWB partitions consistent with the Tenant's use of space as identified by King County. Fire ratings as required by life safety and other building requirements.
3. Partition Components:
 - a. Framing: 3-5/8 inch deep, or as required to meet design requirements; ASTM C 645 with manufacturer's standard corrosion-resistant zinc coating.
 - b. Deflection Track: 2-inch deep flanges at connections to structural deck and as required by building shell construction.
 - c. Sheet Blocking: 0.027 inch thick steel sheet.
 - d. Gypsum Wallboard: ASTM C36. 5/8 inch Type X, tapered edges.
 - e. Finish: Level 4; satin and semi-gloss paint finishes.
 - f. STC-Rated Assemblies: Seal construction at perimeters, behind control and expansion joints, and at openings and penetrations with a continuous bead of acoustical sealant. Install acoustical sealant at both faces of partitions at perimeters and through penetrations.
 - g. Sound Attenuation Blankets: ASTM C 665, Type I, glass, slag wool, or rock wool. 3 inch thick between studs, and 48 inch wide, 3 inch thick continuous loose-lay batt centered over partitions and ceiling tile at perimeter of space.
4. Access Flooring Type 2: If available, utilize existing building system. Where no access floor is installed provide code compliant ramps and stairs to raised access floor areas.
5. Carpet Tile: For installation over access flooring Lees, Shaw or approved commercial carpet tile equal or exceeding the following specifications:

Construction:	Tufted loop pile
Gauge:	1/8"
Stitches per inch:	8.3
Finished Pile Thickness:	.145"
Dye:	yarn dyed
Face weight:	26 oz/yd
Size:	24"x24"
Static performance:	Text Method NFPA 99 RTG 1.5 x 10(5) Ohms minimum, 2.0 x 10(10) Ohms maximum
Adhesive:	Conductive releasable type
Flammability:	DOC-FF-1-70 Pill Test
Radiant Panel Test:	NFPA 1
6. Resilient Static Control Flooring: Rubber Tile, Noraplan duo el, Article 270

Type:	ESD control, electrically conductive
Finish:	smooth surface
Size:	24 inches by 24 inches, 2.5 mm (0.10 inches)
Conductivity Warranty:	5 year wear; 10 year conductivity.
7. Resilient Base: 6-inch resilient base at all walls.

8. Suspended Ceiling Systems (SAC 2):
 - a. Tile: Armstrong Ultima type 1914, or approved beveled tegular tile, 24 in. x 48 in. x 15/16 in. thick, color: White; NRC .70; Light reflectance 90%; Class A Flame spread
 - b. Ceiling Suspension System: Prelude XL exposed tee. Seismically brace per IBC/SBC requirements.

END OF ARCHITECTURAL

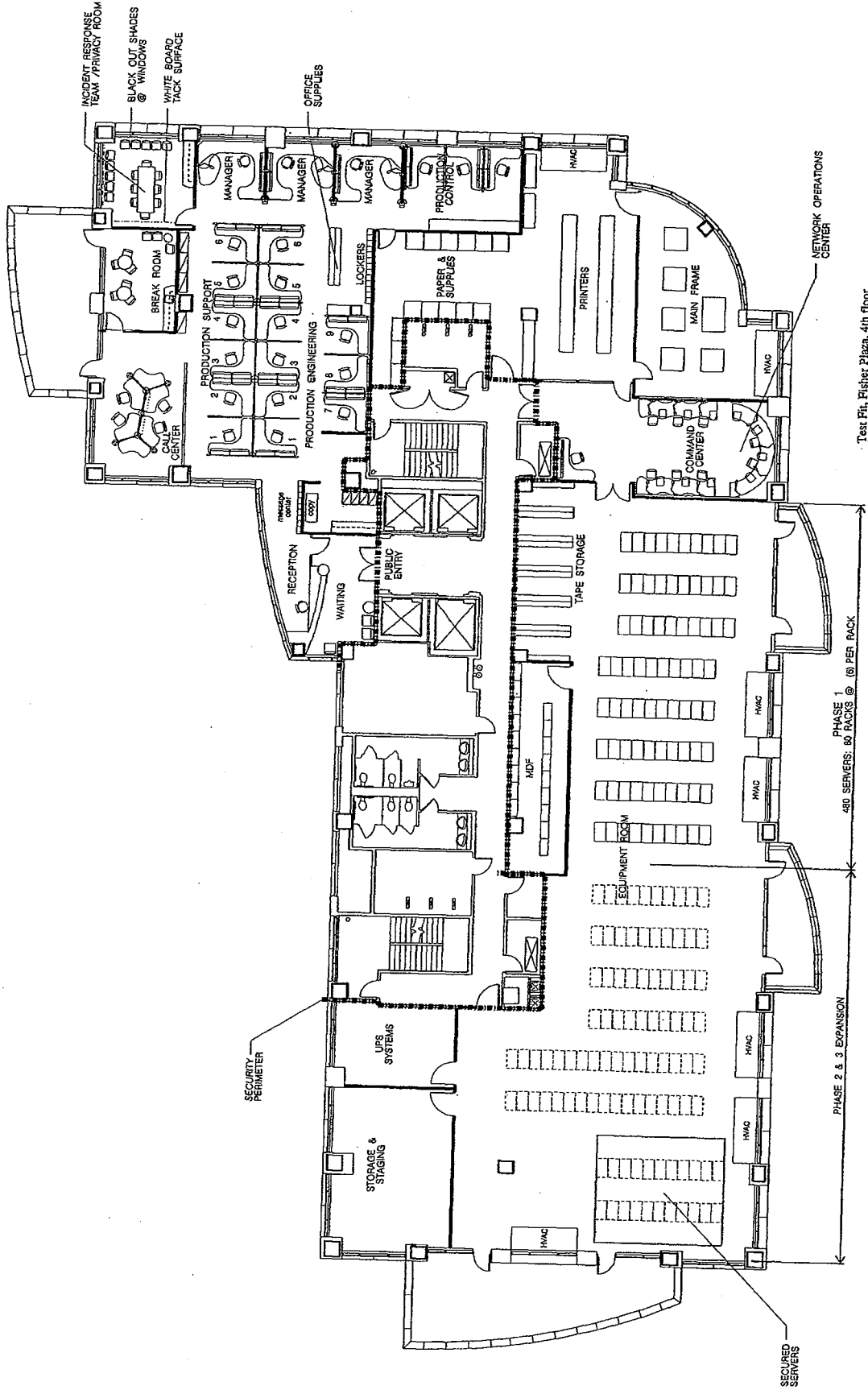

Test Pit, Fisher Plaza, 4th floor
 king county data center
 0 4 8 16 32 ft
 2/15/07
 sazen group / burfordesign

MECHANICAL GENERAL	2
1.0 Scope.....	2
2.0 Standards And Codes	2
3.0 Utilities.....	2
3.1 Plumbing	2
4.0 Quality Assurance	3
4.1 Substitutions.....	3
4.2 Tests And Demonstration	3
4.3 Qualifications	3
5.0 Work Of Other Trades	3
5.1 Coordination	3
6.0 General Requirements	3
7.0 Detail Drawings By Contractor	4
8.0 Submittals	4
8.1 General	4
9.0 Electrical Work.....	5
10.0 Operating And Maintenance Instructions And Manuals.....	5
11.0 As-Built (Record) Drawings	6
12.0 Instruction For Owner's Personnel	6
13.0 Completion Of Work	6
14.0 Materials And Workmanship Guaranty	6
15.0 Inspection	6
16.0 Motors	7
17.0 Vibration Isolation Mountings	7
18.0 HVAC	8
18.1 Raised Floor Cooling	8
18.2 Non-Raised Floor Cooling	9
18.3 Room Control - Did.....	10
18.4 HVAC - General	11
19.0 Plumbing.....	12
20.0 Fire Protection	12

MECHANICAL GENERAL

1.0 SCOPE

- A. The mechanical work will include:
 - 1. Utilities (extend building systems).
 - 2. Heating, Ventilation, and Air Conditioning (HVAC).
 - 3. Plumbing.
 - 4. Fire protection (sprinklers and FM200).
- B. Alternative Bids:
 - 1. M-1 CRAC Unit Manufacturer: Provide alternative price for Data Air CRAC units instead of Liebert. See Paragraph 18.1
 - 2. M-2 FM 200: Provide alternative price for adding FM200 to pre-action system. See Paragraph 20.

2.0 STANDARDS AND CODES

- A. Applicable industry codes, standards, or publications referenced hereinafter apply to equipment, materials, and construction covered herein. See General Provisions Section for list of references.
- B. Work will be installed in conformity with the following codes:
 - 1. Washington State Energy Code (2006) -- with Seattle Amendments.
 - 2. Washington State Ventilation and Indoor Air Quality Code.
 - 3. Uniform Plumbing Code (2003) – with Seattle Amendments.
 - 4. International Building Code (2003) – with Seattle Amendments.
- C. Temperature Standards for Design:
 - 1. Outdoor Standards:
 - a. Winter: 24 degrees F (Seattle, WA).
 - b. Summer: 88 degrees F dry bulb, and 68 degrees F wet bulb (0.1% Seattle, Washington)
 - c. See program matrix attached.

3.0 UTILITIES

3.1 Plumbing

- A. Connect plumbing services to existing building services – cold water, fire sprinklers, hot water, waste, vent, and roof drainage.

4.0 QUALITY ASSURANCE

4.1 Substitutions

- A. Whenever any material or equipment is specified by patent or proprietary name or by the name of the manufacturer, such specification establishes the standard of quality in that particular field of manufacture.
- B. When approved substitute equipment or material necessitates revisions to the plans or involves other trades, include drawings and details showing all such changes, and coordinate and assume any liability from the affected trades.
- C. Acceptance: The acceptance of a manufacturer's name or product by the A/E does not relieve the Contractor of the responsibility for providing materials and equipment which comply in all details with the requirements of the contract documents.

4.2 Tests And Demonstration

- A. Demonstrate that all equipment operates as indicated as specified, and in accordance with the manufacturer's recommendations. Perform tests in the presence of the A/E. Provide all instruments and personnel required to conduct the tests.
- B. Perform testing and balancing (TAB) by subcontractor independent of Mechanical and General Contractor and approved by Engineer. Neudorfer is pre-approved.
- C. Assist Owner's commissioning agent (Sazän Group) during design and construction.

4.3 Qualifications

- A. Use sufficient journeyman and competent supervisors in the execution of the work to ensure proper and adequate installation throughout. In the acceptance of installed work, no allowance will be made for lack of skill on the part of the workmen.

5.0 WORK OF OTHER TRADES

5.1 Coordination

- A. Plan and execute work including, but not limited to, piping and ductwork, in cooperation with all other trades particularly Electrical, Acoustical Ceilings and drywall. Make every reasonable effort to provide all concerned with timely notice of work affecting other trades to prevent conflicts or interference as to space requirements, dimensions, openings, block-outs, sleeves, or other matters which will cause delays or necessitate work-around methods. Failure to coordinate work will be considered sufficient cause for work to be altered at Contractor's expense, as directed by Owner's Construction Manager.

6.0 GENERAL REQUIREMENTS

- A. Related Work: Comply with the provisions of all other divisions, parts or sections of the specifications wherever applicable.

7.0 DETAIL DRAWINGS BY CONTRACTOR

- A. Wherever the work is of sufficient complexity to warrant additional detailing, prepare additional detail drawings to scale 1/4 inch = 1 foot, prepared on tracing paper the same size as contract drawings; with these layouts, coordinate work with the work of other trades. All such detailing work shall be clearly identified on the drawings as to the area to which it applies. As a minimum provide detail drawings for Level 4.
- B. Submit these drawings to the Owner's Construction Manager for approval. At completion, however, include a set of such drawings with each set of as-built drawings for Owner's record purposes.

8.0 SUBMITTALS

8.1 General

- A. Submit, at one time, all equipment and materials for acceptance prior to installation. Partial submittals will not be accepted.
- B. Bind submittals in a hanging, view, 3-post binder. Binder shall be Wilson-Jones WLJ36549W or WLJ36544W, no substitution.
- C. Reference all items by paragraph number. Fold drawings to 8-1/2-inch size and bind as above or place in pocket of folder. Provide transmittal letter with index of all items submitted, including catalog numbers or drawing numbers if appropriate.
- D. List of Manufacturers: Submit within 30 days after award of contract a Bill of Materials containing items to be used on this project, listing manufacturer's name and catalog numbers (where applicable) and referenced to the applicable specification paragraph.
- E. Provide shop drawings, descriptive bulletins, data sheets, diagrams, catalog cuts or other additional information as required for the items specified hereinafter in other sections.
- F. Acceptance: The acceptance of a manufacturer's name or product by the Engineer does not relieve the Contractor of the responsibility for providing materials and equipment that comply in all details with the requirements of these requirements.
- G. When changes and an additional review are required, the changes shall be highlighted with yellow marker. Only the material so marked will be reviewed.
- H. Shop Drawings
 - 1. Sleeve Installation
 - 2. Ceiling Hanger Installation
 - 3. Bolt Setting Information
 - 4. Seismic Restraints
 - 5. Provide a complete set of vendor shop drawings of major mechanical equipment items including, but not limited to: pumps, air handling units, fans, etc. These shall be used for coordination of seismic restraints; refer to paragraph "Equipment, Piping and Ductwork Seismic Restraints."

- I. Product Data
 - 1. Motors
 - 2. Variable Speed Drives
 - 3. Motor Control Equipment
 - 4. Beam Attachments
 - 5. Ceiling Hangers
 - 6. Vibration Isolation Mountings
 - 7. Pipe Markers
- J. Electrical: See paragraph below.

9.0 ELECTRICAL WORK

- A. Review electrical requirements in the General and Electrical sections shown in more than one place of the Contract Documents. After making this review, notify the Owner's Construction Manager of any conflicts. Equipment shall not be ordered or electrical installation started until the conflicts are resolved. The Contractor shall make this review immediately after the Notice to Proceed is issued and before the construction schedule is affected by the time required to make any required changes.
- B. Refer to Electrical Section for motor starters and motor circuit protective devices for equipment included in Division 15 unless the starters are supplied (manufactured) as an integral part of the equipment or as specified otherwise.
- C. The Electrical Contractor is responsible for providing power outlet boxes for each piece of equipment, installing electrical devices and connecting them to the equipment.

10.0 OPERATING AND MAINTENANCE INSTRUCTIONS AND MANUALS

- A. Prepare three copies of an operating and maintenance manual for all equipment provided under Division 15 in accordance with Division 1 and the following paragraphs.
- B. Information Contained:
 - 1. Manuals shall include control diagrams and maintenance information and parts lists furnished by the manufacturer for the equipment. Clearly identify options provided for each piece of equipment.
 - 2. Data in manuals shall be neat, clean copies. An index shall be provided with all contents listed in an orderly presentation, similar to the arrangement of the specifications. Indicate date of guarantee.
 - 3. Include filter maintenance, oiling instructions, methods of operation, seasonal requirements, manufacturer's data and warranty forms. Provide address and 24-hour phone number of firm responsible under warranty.
- C. Bind submittals in a hanging, view, 3-post binder. Binder shall be Wilson-Jones WLJ36549W or WLJ36544W, no substitution.

- D. Approval: Prior to binding the final copies submit a single loose copy to the Engineer for approval, no later than 60 days before the scheduled completion date.

11.0 AS-BUILT (RECORD) DRAWINGS

- A. Furnish as-built (record) drawings to the A/E.
1. Conform to requirements of General Section.
 2. Post all addenda and other changes.
 3. Drawing shall be same size as the Contract Documents. Mark in new work in red, existing work in green, and deletions in silver.

12.0 INSTRUCTION FOR OWNER'S PERSONNEL

- A. Following the installation of all mechanical equipment and prior to acceptance of the mechanical work, conduct demonstrations and instruction periods for Owner's representatives to point out the location of servicing points and required points of maintenance. Provide a qualified foreman or superintendent from the trade involved as an instructor. For Control Systems, the Engineer who performs testing and adjustment shall be responsible for instruction on the temperature control system. Their qualifications shall be submitted before conducting the instruction, if requested by the Owner's Construction Manager.
- B. Each instruction period shall include a preliminary discussion and a presentation of information in the maintenance manuals, with appropriate references to drawings; tours of the building areas, with explanations of maintenance requirements, access methods, servicing and maintenance procedures, equipment cleaning procedures, temperature control settings and adjustment locations.
- C. Advise the Owner's Construction Manager two weeks prior to conducting instructions and demonstrations. Make final arrangements after receiving approval from the Owner's Construction Manager.

13.0 COMPLETION OF WORK

- A. When requesting final inspection, give 10 days' notice. Submit written certification that the work has been fully completed in strict accordance with plans and specifications.
- B. At final inspections the contractor shall provide completed TAB report, commission report, O and M manuals, as-built drawings and signal permits.
- C. All of the work described herein shall be performed prior to installation of server racks and telecommunication cabling.

14.0 MATERIALS AND WORKMANSHIP GUARANTY

- A. Submit written guaranty that all materials and workmanship that prove defective within one year after date of acceptance will be replaced. Comply with the requirements of Division 1.

15.0 INSPECTION

- A. Submit written certification of inspection from the governing building authority stating that all work has been inspected, accepted, and approved as complying with existing governing ordinances and codes. A completed permit shall satisfy this requirement.

16.0 MOTORS

- A. Design and Construction: Unless otherwise specified, provide electric motors and enclosures conforming to the applicable definitions and requirements of NEMA MG1 "Motors and Generators."
- B. Manufacturers: General Electric, Baldor, Reliance, Marathon, U.S. Motors, or approved; one HP and larger shall be high efficiency equivalent to Goulds "E" plus, Marathon Series "E," G.E. "Energy Saver," or Baldor "Super E."
- C. Type and Construction
 - 1. Electrical phase and voltages specified here are a general standard. Refer to Electrical Section. Motors one-third HP and smaller shall be single-phase capacitor type. One-half HP and Larger shall be three-phase, single-speed induction type.
 - 2. Service Factor shall not be less than 1.1.
 - 3. Motor Frames: Open drip-proof construction; for motors exposed to the weather - totally enclosed.
 - 4. Motors used with variable speed drives shall be approved for use with the variable speed drive model and manufacturer used. Marathon, General Electric, Baldor, Reliance, U.S. Motors, Lincoln, or approved.

17.0 VIBRATION ISOLATION MOUNTINGS

- A. Provide vibration isolation mountings for equipment, (piping and ductwork) as indicated. All metal exterior vibration equipment exposed to the weather shall be neoprene coated or hot dip galvanized.
- B. Manufacturer: Mason, Dynasonics, Vibron, Kinetics, Amber/Booth, Vibrex, Vibro-Acoustics, Korfund, or approved.
- C. Anchor Bolts: Provide galvanized bolts for each isolator; two minimum for each unit.
- D. Computations: Following selection of equipment mounted on isolation mountings, the manufacturer shall prepare computations with vibration isolation mountings selections and showing how vibration isolation efficiency will be produced; submit for review prior to ordering materials.
- E. Provide spring isolation of the stable housed type, with built-in horizontal and vertical snubbers consisting of neoprene or rubber inserts. Provide a 1/4-inch thick pad of waffle type neoprene between the mount and the bearing surface. Provide restrained spring mounts and height saving brackets for floor-mounted equipment.
- F. Isolator Types:
 - 1. Type 1. Two layers of 3/4" thick neoprene pad consisting of 2" square waffle modules separated horizontally by a 16 gauge galvanized shim. Load distribution plates shall be used as required. Pads shall be Type Super "W" as manufactured by Mason Industries, Inc.
 - 2. Type 2. Bridge-bearing neoprene mountings shall have a minimum static deflection of 0.2" and all directional seismic capability. The mount shall consist of a ductile iron casting containing two separated and opposing molded neoprene elements. The

elements shall prevent the central threaded sleeve and attachment bolt from contacting the casting during normal operation. The shock absorbing neoprene materials shall be compounded to bridge-bearing specifications. Mountings shall have an Anchorage Pre-approval "R" Number from OSHPD in the State of California verifying the maximum certified horizontal and vertical load ratings.

3. Type 5. Spring isolators shall be free standing and laterally stable without any housing, and complete with a molded neoprene cup or 1/4" neoprene acoustical friction pad between the baseplate and the support. All mountings shall have leveling bolts that must be rigidly bolted to the equipment. Spring diameters shall be no less than 0.8 of the compressed height of the spring at rated load. Springs shall have a minimum additional travel to solid equal to 50% of the rated deflection. Submittals shall include spring diameters, deflection, compressed spring height and solid spring height.
4. Type 16. All directional seismic snubbers shall consist of interlocking steel members restrained by a one-piece molded neoprene bushing of bridge bearing neoprene. Bushing shall be replaceable and a minimum of 1/4" thick. Rated loadings shall not exceed 1000 psi. A minimum air gap of 1/8" shall be incorporated in the snubber design in all directions before contact is made between the rigid and resilient surfaces. Snubber end caps shall be removable to allow inspection of internal clearances. Neoprene bushings shall be rotated to insure no short circuits exist before systems are activated.

18.0 HVAC

18.1 Raised Floor Cooling

- A. Provide cooling in the raised floor area with CRAC (Computer Room Air Conditioning) Units. The initial construction will include a minimum of six (6) CRAC units (5 for load and one for standby) 35-ton chilled water down-flow units, Liebert (total 165 tons, and one 35-ton unit as standby, N+1 redundancy; total 210 tons). Cooling shall be based on a minimum of 1,050 kW of internal load plus building heat gain to outside and adjacent spaces. Submit calculations to substantiate selections. Provide alternative bid (M-1) for manufacturer other than Liebert (Data Aire is pre-approved).
- B. Provide each new CRAC with identical features. The components of the new CRACs will include, in order of airflow:
 1. Outside air louver with birdscreen (located on outside wall).
 2. Mixed air plenum (mixing outside air and return air as directed by control system, see below).
 3. Filter (35% efficient) – Farr 30/30.
 4. Chilled water cooling coil with modulating two-way valve.
 5. Supply fan (multi-scroll fan on common shaft).
 6. Air deflecting vanes under the floor.

7. Floor stand to support the CRAC independent of the raised floor and bracing to the structure for seismic support (SHL-AA).
 8. Smoke detector (connect to building fire alarm).
 9. Floor grilles arranged for hot and cold aisles.
- C. Provide chilled water distribution piping from the main building risers to the new CRAC locations. Provide three risers (minimum of three) to independently supply chilled water from the building mechanical room. New piping shall be piped under the floor.
- D. Chilled water system shall be independent of other cooling systems in the building. Provide steel (schedule 40, grooved joint or threaded) or type K copper piping. Insulate with 2-inch closed cell (Armaflex or approved). Provide building chilled water distribution so that complete building cooling load can be met with one chiller, one chilled water pump, one cooling tower, or one condenser water pump off-line (in repair; i.e. N+1 redundancy).
- E. Exhaust: When the CRACs are operating on outside air (economizer), the room air will be relieved by pressure sensitive exhaust fans. Provide the exhaust fans with speed drives and sound attenuators. Install exhausts 20 feet away from outside air intake.
- F. Controls:
1. Provide separate temperature controls for Command Center NOC (Network Operations Center), printer room, and mainframe area.
 2. See Room Control paragraph below.
- G. Maintenance: Arrange layout to allow service and adjustment of components.
- H. Scalability: Arrange layout for future addition of additional CRAC units (indicate at least two additional units).

18.2 Non-Raised Floor Cooling

- A. Office Area System: Provide an independent office area air conditioning system (independent of the CRACs). Provide a chilled water air handling unit (AHU) for air distribution to the offices through overhead or under floor distribution. The components of the new AHU will include, in order of airflow:
1. Outside air louver with bird-screen (located on outside wall).
 2. Mixed air plenum (mixing outside air and return air as directed by control system, see below).
 3. Filter.
 4. Chilled water cooling coil with modulating two-way valve.
 5. Supply fan (plug fan) with speed drive (VFD, variable frequency drive – See Electrical Section).
 6. Sound attenuator.
 7. Floor stand to support the CRAC independent of the raised floor.

8. Smoke detector.
 9. Air terminal units – series fan powered.
 10. Return fan with speed drive (VFD – See Electrical Section).
 11. Sound attenuator
 12. Recirculation damper
 13. Exhaust damper
 14. Exhaust louver with bird screen
- B. Office Air Distribution: Provide variable air volume (VAV) air distribution with fan-powered VAV units with supplemental electric heat. Air will be delivered with ceiling diffusers or floor grilles. Provide separate zones of air distribution on building corners (15'x15' maximum) and 15-foot wide perimeter zones (maximum 500 SF per zone).
- C. Provide exhaust in toilet rooms, break area, print room, and locker rooms.

18.3 Room Control - DDC

- A. Provide a DDC temperature control system for the CRACs and AHU-1. The system may be the building Direct Digital Control (DDC) system. Provide linkage so County Facilities engineers can monitor the system at the King County Administration Building (or in a location designated by them) and the Owner's network engineer can monitor and adjust set-points at the engineer's desk or remote from the building.
- B. Provide room temperature sensors in various locations in the raised floor area to control the operation (On-Off) of the CRACs and the temperature control.
- C. Provide room temperature sensors in separate zones in the office areas. Each zone will have an electric coil to temper the air supply to the room.
- D. Points of control shall include the following:
 1. CRAC (each):
 - a. CRAC start/stop
 - b. CRAC operating
 - c. Mixed air temperature.
 - d. Filter pressure, alarm if too high.
 - e. Chilled water supply temperature.
 - f. Supply air temperature.
 - g. Smoke detector.
 - h. Return air temperature.
 - i. Return air humidity (%RH).

- j. Supply air humidity (%RH).
- k. Room temperature sensor.
- 2. AHU:
 - a. AHU start/stop (monitor).
 - b. AHU operating.
 - c. VFD speed, power.
 - d. Outside air temperature.
 - e. Mixed air temperature
 - f. Filter pressure, alarm if too high.
 - g. Chilled water supply temperature.
 - h. Supply air temperature.
 - i. Supply air pressure (control to 1.0 inches, alarm at 2.5 inches).
 - j. Smoke detector (as above).
 - k. Each VAV box, monitor CFM, discharge temperature, room temperature
 - l. Return air humidity (% RH)
- 3. Automatic Reset: Provide automatic reset of temperature and humidity setpoints to optimize operation. For example, if it takes less energy to operate the facility with return air instead of outside air, adjust operation accordingly.
- 4. Security system: Monitor trouble and fire alarms.
- 5. Fire alarm system: Monitor trouble and fire alarms.
- 6. Miscellaneous:
 - a. Under-floor moisture (monitor each zone).
 - b. Coordinate with the data center fire suppression system (FM200).
 - c. Provide maintenance scheduling and monitoring.
 - d. Indicate ability to provide open protocols.

18.4 HVAC - General

- A. Provide sheet-metal supply and exhaust air routed to and from various spaces. Duct-board will not be allowed. Insulate new supply ductwork from main AHU to VAV terminal units and from terminal units to diffusers.
- B. Flexible ducts are allowed to supply diffusers and return/exhaust grilles, no longer than 8 feet in length and not to replace fittings. Provide full radius bends where possible. Connections at hard ductwork shall be double tye-wrapped.
- C. Provide a volume damper for each supply diffuser and ducted return/exhaust grille. Locate as far from the opening as possible.

- D. Provide fire/smoke dampers at all fire-rated penetrations. Coordinate fire-ratings with the Architect to verify separation code compliance.
- E. Provide a leak detection system arranged for one zone per CRAC.
- F. Noise, vibration, and seismic control will be maintained to noise levels below NC-40 or as noted above.
- G. All HVAC systems for the data center shall be supported for Seismic Hazard Level AA (SHL-AA) as called for in SMACNA Seismic Design Manual. Bracing shall include lateral support of CRACs, chilled water pipes, server racks, etc. Seismic support to structure shall not interfere with vibration isolation (provide neoprene snubbers or approved). Instead of SHL-AA, provide lateral support conforming to IBC 2003 for critical equipment and occupancies.
- H. Test all air systems for capacity (air balance). See above.
- I. Test all mechanical systems and controls for proper function (commissioning) prior to moving of the electronic servers into the data center. As part of the commissioning, the CRACs and control system shall be tested with heaters sufficient to match the capacity including load banks as necessary to test both the CRACs and power system. See above.

19.0 PLUMBING

- A. Provide fixtures and services to suit the architectural layout.
- B. Extend building hot water system to new fixtures. Provide tempering control (mixing 140 F and 50 F water) to 120 degrees F as necessary to comply with code.
- C. Provide new circulation pump(s) to continuously circulate the hot water within the systems. Extend circulation to ensure that fixtures are not more than 10' from recirculated hot water.
- D. Existing plumbing will remain. Provide new floor drains near the CRACs as necessary for gravity condensate drainage.
- E. Plumbing piping will include:
 - 1. Standard weight no-hub cast iron for waste and vent.
 - 2. Type L copper for domestic hot and cold water. Provide new backflow valves at the cold water service and at the cold and hot water services to the Laboratory.
 - 3. Insulate domestic hot water and circulating hot water with 1-inch thick glass fiber with high density, white vapor barrier jackets.
 - 4. Insulate domestic cold water with 0.5-inch thick glass fiber with high-density, white vapor barrier jackets.
 - 5. Insulate all rain-leaders in data center space.
 - 6. Insulate traps under sinks and lavatories where subject to patients or staff getting burned. Provide ½-inch thick insulation with high-density plastic jacket, pre-manufactured for this type of installation. Comply with ADA requirements.

20.0 FIRE PROTECTION

- A. Modify existing wet pipe sprinkler system to serve the revised architectural and room configuration in the non-raised floor area.

- B. Modify the existing wet pipe sprinkler system for a pre-action system to serve the revised room configuration in the entire raised floor area. Coordinate the interlock with the fire alarm system (VESDA system) to prevent false discharge.
- C. Sprinkler system shall comply with NFPA 13, Light Hazard Classification as approved by the Seattle Fire Department.
- D. The sprinkler heads will be standard response, semi-recessed type and will be located in the center of the ceiling tiles.
- E. Piping will be schedule 40, black steel.
- F. Alternate Bid M-2: Provide an alternative bid for a gaseous (FM 200, FE227, or Inergen) fire suppression system (in addition to the pre-action system).
 - 1. The system shall be provided with gaseous agent, charged, tested, and integrated with cross-zoned smoke detection (addressable) system.
 - 2. Provide room integrity test.
 - 3. Installing Contractor: Fire Chief Equipment or approved.
 - 4. Connect cross-zoned detection system with building fire alarm system.
 - 5. Provide control panel with at least three audible circuits (24V DC), three audible silence switches, alarm and trouble contacts, diagnostic LED for troubleshooting, solid-state time delay (0-60 seconds), abort options, batteries, microprocessor, release output switch, detection and cross-zone detection capability, and parallel, wired-agent release module with electrical initiators.
 - 6. Manual release switch.
 - 7. Abort station.
 - 8. Audible and visual alarms.
 - 9. System inspection, checkout and acceptance testing.
 - 10. Close-out requirements including a room integrity test, detector test, equipment, interlock test, Owner training, O&M manuals, record drawings, and acceptance testing.

END OF MECHANICAL

Sazan Group, Inc.
 720 Olive Way, Suite 1525
 Seattle, Washington 98101

King County Data Center Relocation
 Seattle, Washington

Data Center Relocation - Space Program

Date: 01/16/07

Space	Occ., # of people	Area, SF	Ceiling Height, ft	Raised Floor	Temp, Degree F	Relative Humidity, %	Noise Level, NC	Fire Protection	Remarks
A Raised Floor - Server Room and Tape Storage	10	12,499	10 ft	Y	66+/-2	45+/-10	45	FM-200	Area includes CRACs, PDUs, expansion space, circulation space, tape storage
B Main Frame	2	700	10 ft	Y	66+/-2	45 +/--10	45	FM-200	
C UPS Room	2	500	8.5 ft	Y	72+/-2	25 - 55	45	FM-200	
D MDF Room	2	120	10 ft	Y	66+/-2	45+/-10	45	FM-200	
E IDF Room #1	2	120	10 ft	Y	66+/-2	45+/-10	45	FM-200	
F IDF Room #2	2	120	10 ft	Y	66+/-2	45+/-10	45	FM-200	
G Command (Network Operations Center)	6	1000	8.5 ft	Y	72	40+/-10	35	Pre-action	Separately switched lighting
H Printer Room	4	500	8.5 ft	N	72	40+/-10	50	Pre-action	Dust filters
I Paper storage room	2	600	8.5 ft	N	72	30+/-10	45	Pre-action	
J Office and Locker Room	25	3500	8.5 ft	N	72	30+/-15	40	Pre-action	
K Break room	4	600	8.5 ft	N	72	30+/-15	35	Pre-action	

Notes

1. Ceiling Heights indicated are clear height above finished floor, excludes height of raised floor and return air plenum above the ceiling
2. For adjacency requirements, see space diagram
3. All areas with FM-200 to also be provided with Preaction Sprinklers and a VESDA system
4. Area Square Footages are preliminary, net useable.
5. UPS = Uninterruptible Power Supply
6. MDF = Main Distribution Frame
7. IDF = Intermediate Distribution Frame

ELECTRICAL - GENERAL	2
1.0 Scope.....	2
2.0 Standards And Codes	2
2.2 Definitions	2
3.0 Data Center Auxiliary Systems.....	2
4.0 Lighting Design	3
4.1 General	3
4.2 Lighting Levels	3
4.3 Lighting Controls	3
5.0 Electrical Systems	3
5.1 General	3
5.2 Electrical Distribution	4
5.3 Load Calculations And Load Density Allowances	4
5.4 Switchboards and Panels.....	4
5.5 Materials and Equipment.....	5
5.6 Conduit and Fittings	5
5.7 Surface Metal Raceway	5
5.8 Cable Trays.....	5
5.9 Open Telecommunications Cable Support.....	6
5.10 Telecommunications Pathways	6
5.11 Outlet Boxes and Covers	6
5.12 Wires and Cables.....	7
5.13 Switches.....	7
5.14 Receptacles (NEMA WD 6)	8
5.15 Branch Circuits and Equipment Connections.....	8
5.16 Panelboards.....	9
5.17 Transformers	9
5.18 Underfloor Wiring	9
6.0 Electrical Connections For Mechanical Equipment.....	10
6.1 Extent of Electrical Connections	10
6.2 Tier 3 Circuiting Requirements.....	10
6.3 Computer Room Air Conditioning (CRAC) Units	10
6.4 Motor Starters and Motor Circuit Protective Devices.....	11
7.0 Telecommunications Grounding And Bonding.....	11
7.1 General Requirements	11
8.0 Standby Power For Emergency Power And Lighting	13
8.1 Engine-Generator	13
8.2 Uninterruptible Power Supply (UPS).....	13
8.3 Battery for Standby Power	13
8.4 Emergency Power	13
8.5 Emergency Lighting.....	13
9.0 Fire Protective Systems.....	14
9.1 General	14
9.2 System Devices for Fire Alarm	14
9.3 Automatic Detection Systems	14
9.4 Annunciator Panels.....	15
10.0 Security Systems.....	15
10.1 Video Surveillance System.....	15
10.2 Access Control	15
10.3 Physical Security	15

ELECTRICAL - GENERAL

1.0 SCOPE

- A. The purpose of this document is to provide requirements and guidelines for the design and installation of a Data Center electrical distribution system. It is intended for use by designers who need a comprehensive understanding of the data center design including the facility planning and associated cabling and network system designs.
- B. The design criteria and standards contained within are the minimums acceptable for efficiency, economy, durability, maintainability, and reliability of electrical power supply and distribution systems.
- C. Clarifications of baseline design criteria, standards, policy, and guidance should be obtained through the normal communications channels established between the owner and contractor.

2.0 STANDARDS AND CODES

- A. Applicable industry codes, standards, or publications referenced hereinafter apply to equipment, materials, and construction covered herein. See General Provisions Section for list of references.
- B. The minimum requirements of the latest edition of International Building Code (IBC), NFPA 70, and National Electrical Code (NEC) shall apply unless more stringent requirements are specified and/or dictated.

2.2 Definitions

- A. Unless otherwise specified or indicated, electrical and electronics terms used in these specifications, and on the drawings, shall be as defined in IEEE Std 100.

3.0 DATA CENTER AUXILIARY SYSTEMS

- A. Provide complete design and installation of all required data center auxiliary and monitoring systems. Required systems include but are not limited to:
 - 1. Fire Protective Systems
 - 2. Fire Detection and Alarm system
 - 3. Access Control System
 - 4. Intrusion Detection System
 - 5. Video Surveillance Systems
 - 6. Underfloor Water-leak Detection Alarm
- B. Refer to the Mechanical section for any of the above systems being provided under that section, or requiring electrical connections and/or control interface to systems provide under this section.

4.0 LIGHTING DESIGN

4.1 General

- A. Coordinate placement of lighting with equipment layouts so that lighting fixtures are placed in aisles between cabinets and racks instead of directly over equipment rows or above cable trays.
- B. Service and Access: Locate lighting fixtures to enable reasonable access for service and relamping.
- C. Lighting fixtures shall not be powered from the same electrical distribution panel as the computing equipment in the Data Center/Server Room.
- D. Circuiting: Provide separate circuits and switching for fixtures located in the Command Center/NOC, Data Center/Server Room, MDF, Main Frame, and Printer Room.
- E. Fluorescent Lamps: Provide tri-phosphor 2700K to 3500K color temperature; 4 ft. maximum length for ease of storage.
- F. Emergency lighting and signs shall be properly placed per authority having jurisdiction (AHJ) such that an absence of primary lighting will not hamper emergency exit.

4.2 Lighting Levels

- A. Data Center/Server Room, MDF, Main Frame, and Printer Room: Lighting shall be a minimum of 50 footcandles in the horizontal plane and 20 footcandles in the vertical plane, measured three feet above the finished floor in the middle of all aisles between cabinets.
- B. Other areas of the data center: Design lighting systems to provide minimum foot candle levels in compliance with IES recommended practices.

4.3 Lighting Controls

- A. Offices: Locally switched, Adjustable occupancy sensors
- B. Data Center/Server Room: Continuously on; locally switched, multi-zone
- C. Corridors: switched daily, local switch; continuously on, panelboard switch
- D. Command Center/NOC: dimmer controlled, dimmer switch; continuously on, panelboard switch; switched daily, local switch.

5.0 ELECTRICAL SYSTEMS

5.1 General

- A. Review the architectural drawings and system requirements described herein to determine the power supply configurations required to achieve the necessary degree of reliability, durability, maintainability, efficiency, and economy.
 - 1. The electrical System design shall provide a system that consistently and reliably provides power to the facility.
 - 2. Electrical systems and electrical equipment shall be designed for the design life of the facility: 15 years

3. The design of electrical systems shall incorporate features which provide access space for maintenance in accordance with NFPA 70 and means to replace equipment and field installed wiring without significant demolition and reconstruction of the facility.
- B. The electrical distribution system shall be designed to facilitate power monitoring of feeders and branch circuits within the Data Center/Server Room.

5.2 **Electrical Distribution**

- A. Electrical distribution systems shall meet the requirements for a Tier-3 Fault Tolerant classification as defined by The Uptime Institute, Inc. for a concurrently maintainable site infrastructure:
 1. System Component Redundancy: N+1
 2. Distribution Paths: (1) Normal and (1) Alternate
- B. Power Distribution
 1. General Distribution: 277/480 Volt and 120/208 Volt sub-distribution panels for lighting, receptacles, appliances circuits, and mechanical equipment.
 2. Data Center Distribution: UPS-backed PDU; Tier-3 compliant

5.3 **Load Calculations And Load Density Allowances**

- A. Branch circuit, feeder, and service load calculations shall be based on NFPA 70 Article 220 as amended by WAC 296-46B for all areas of the data center. Loads calculations shall include:
 1. Lighting
 2. General purpose receptacles
 3. HVAC motors and compressors
 4. Electric heat
 5. All miscellaneous electrical loads associated with the data center.
- B. In addition to the loads calculated above, an allowance of 150 W/sq. ft. shall be included for computing loads in the following rooms or areas:
 1. Data Center/Server Room
 2. Main Frame
 3. Command Center/NOC
 4. MDF
- C. Allow a growth factor of 25% above the total demand load calculated in A and B above.

5.4 **Switchboards and Panels**

- A. Main Switchboard: Provide circuit breakers with single main disconnect switch and GFI protection in accordance with NFPA 70.
- B. Sub-distribution Panelboards: Bolt-in circuit breaker type.
- C. Provide separate panels for power and lighting.
- D. Locate panelboards where practicable to limit length of branch circuits to 100 feet or less.

- E. Locate panel boards in secured rooms out of sight of public view, on same floor as load served.

5.5 Materials and Equipment

- A. Materials, equipment, and devices shall, as a minimum, meet requirements of UL, where UL standards are established for those items, and requirements of NFPA 70.

5.6 Conduit and Fittings

- A. Intermediate Metal Conduit (IMC): UL 1242, zinc-coated steel only.
- B. Electrical, Zinc-Coated Steel Metallic Tubing (EMT): UL 797, NEMA C80.3.
- C. Flexible Metal Conduit: UL 1.
- D. Liquid-Tight Flexible Metal Conduit, Steel: UL 360.
- E. Fittings for Metal Conduit, EMT, and Flexible Metal Conduit: UL 514B. Ferrous fittings shall be cadmium- or zinc-coated in accordance with UL 514B.
- F. Fittings for IMC: Threaded-type.
- G. Fittings for EMT: Steel compression type.

5.7 Surface Metal Raceway

- A. UL 5, two-piece painted steel, totally enclosed snap-cover type.
- B. Snap-in device mounting plates for installation of grounding-type twist-loc receptacles for equipment cabinet connections. Receptacles shall be spaced minimum one over every cabinet. Redundant raceways/outlets required.

5.8 Cable Trays

- A. Cable Tray construction shall comply with NEMA VE 1.
- B. Cable trays shall form part of the telecommunications cable pathway system, and shall be Ladder-Type, nominal 4 inch depth, with maximum rung spacing of 6 inches. Cable tray widths shall be as determined by the designer to suit cabling applications.
- C. Cable trays shall be provided as complete systems that include:
 - 1. Splice plates
 - 2. End plates
 - 3. Dropouts
 - 4. and miscellaneous assembly and support hardware.
- D. Edges, fittings, and hardware shall be finished free from burrs and sharp edges. Fittings shall have not less than load-carrying ability of straight tray sections and shall have manufacturer's minimum standard radius.
- E. Overhead cable tray side rails shall be used for mounting Surface Metal Raceways above equipment cabinets to facilitate power wiring and connections.
- F. Cable trays located under access floors shall be the ventilated type to allow airflow. See ANSI/TIA-569-B for further cable tray design considerations.

- G. Under-floor cable tray routing shall be coordinated with other under floor systems during the planning stages of the building. Refer to NEMA VE 2-2001 for recommendations regarding installation of cable trays.
- H. Metallic cable trays shall be bonded to the data center grounding infrastructure.

5.9 Open Telecommunications Cable Support

- A. Open Top Cable Supports: UL 2043. Open top cable supports shall be galvanized or zinc-coated steel.
- B. Closed Ring Cable Supports: UL 2043. Closed ring cable supports shall be galvanized or zinc-coated steel.

5.10 Telecommunications Pathways

- A. See paragraph 10.0, Security Systems, for requirements affecting telecommunications pathway installations.
- B. Design telecommunications cable-supporting structures (pathways), including: outlet boxes, conduits with pull wires, wireways, cable trays, open cable supports, and other accessories for telecommunications pathways in accordance with EIA TIA/EIA-569-A.
 - 1. Horizontal Pathway: Telecommunications pathways from the work area to the telecommunications room shall be designed to comply with cabling length limitations in accordance with EIA TIA/EIA-568-B.1. Conduits, wireways, and cable trays shall be sized in accordance with EIA TIA/EIA-569-A.
 - 2. Backbone Pathway: Telecommunication pathways from the telecommunications entrance facility to telecommunications equipment rooms (backbone cabling) shall be installed in accordance with EIA TIA/EIA-569-A. Conduits, wireways, and cable trays shall be sized in accordance with EIA TIA/EIA-569-A.
- C. Each IDF shall have a single, complete path to the MDF.
- D. Backboards: See Telecommunications Section.

5.11 Outlet Boxes and Covers

- A. Outlet boxes shall comply with UL 514A, cadmium- or zinc-coated ferrous metal; UL 514C nonmetallic.
- B. Outlet Boxes for Telecommunications
 - 1. Standard type 4 inches square by 2 1/8 inches deep for single gang outlets.
 - 2. Standard type 4 11/16 inches square by 2 1/8 inches deep for outlets utilizing optical fiber cabling.
 - 3. Outlet boxes for wall-mounted telecommunications outlets shall be 4 by 2 1/8 by 2 1/8 inches deep. Depth of boxes shall be large enough to allow manufacturers' recommended conductor bend radii.
 - 4. Outlet boxes for optical fiber telecommunication outlets shall include a minimum 3/8 inch deep single or two gang plaster ring and designed using a minimum 1 inch conduit system.

5.12 **Wires and Cables**

- A. Wires and cables shall meet applicable requirements of NFPA 70 and UL for type of insulation, jacket, and conductor specified or indicated.
- B. Wires and cables manufactured more than 12 months prior to date of delivery to site shall not be used.
- C. Conductors:
 - 1. Conductors No. 8 AWG and larger shall be stranded.
 - 2. Conductors No. 10 AWG and smaller shall be solid, except that conductors for remote control, alarm, and signal circuits, classes 1, 2, and 3, shall be stranded unless indicated otherwise.
 - 3. All conductors shall be copper.
- D. Minimum Conductor Sizes:
 - 1. Minimum size for branch circuits shall be No. 12 AWG
 - 2. Class 1 remote-control and signal circuits, No. 14 AWG
 - 3. Class 2 low-energy, remote-control and signal circuits, No. 16 AWG
 - 4. Class 3 low-energy, remote-control, alarm and signal circuits, No. 22 AWG.
- E. Color Coding: For service, feeder, branch, control, and signaling circuit conductors: Color shall be green for grounding conductors and white for neutrals; except where neutrals of more than one system are designed in same raceway or box, other neutrals shall be white with a different colored (not green) stripe for each. Color of ungrounded conductors in different voltage systems shall be as follows:
 - 1. 208/120 Volt, Three-Phase
 - a. Phase A - Black
 - b. Phase B - Red
 - c. Phase C - Blue
 - 2. 480/277 Volt, Three-Phase
 - a. Phase A - Brown
 - b. Phase B - Orange
 - c. Phase C - Yellow
- F. Wire and Cable Insulation Type: As selected by Designer.

5.13 **Switches**

- A. Toggle Switches: NEMA WD 1, UL 20, totally enclosed with bodies of thermoplastic or thermoset plastic and mounting strap with grounding screw. Wiring terminals shall be screw-type, side-wired. Contacts shall be silver-cadmium and contact arm shall be one-piece copper alloy. Switches shall be rated quiet-type ac only, 120/277 volts, with current rating and number of poles required.
- B. Switch with Red Pilot Handle: NEMA WD 1, pilot light integral to the switch's handle. The pilot light shall be red and shall illuminate whenever the switch is closed. The pilot lighted

switch shall be rated 20 amps and 120 volts or 277 volts. Provide the circuit's neutral conductor to each switch with a pilot light.

- C. Breakers Used as Switches: For 120- and 277-Volt fluorescent fixtures, mark breakers "SWD" in accordance with UL 489.
- D. Disconnect Switches: NEMA KS 1.
 - 1. Heavy-duty type for switches rated higher 240 volts, and for double-throw switches.
 - 2. Fused switches shall utilize Class R fuseholders and fuses.
 - 3. Switches serving as motor-disconnect means shall be horsepower rated.
 - 4. Switches enclosure ratings shall be per NEMA ICS 6.

5.14 Receptacles (NEMA WD 6)

- A. UL 498, hard use, heavy-duty, grounding-type, screw-type side-wired wiring terminals; triple-wipe power contacts and double or triple-wipe ground contacts; thermoplastic face and body supported on a metal mounting strap.
- B. General use: Maximum of five per 20A, 120V circuit.
- C. Tech offices, staging, and operations rooms: Maximum of two per 20A, 120V circuit, located on each wall with one on each side of a door.
- D. Corridors: Maximum of three per 20A, 120V circuit located at 25 ft. intervals.
- E. Administration Areas: Maximum of four per 20A, 120V circuit located at desks and work areas for electronic equipment, lamps, and convenience.
- F. Mechanical Areas: Maximum of five per 20A 120V circuit located within 25 ft. of all mechanical equipment.
- G. Data Center Equipment Cabinet Connections: Redundant 30 Amp, 120/208V 3-phase dedicated circuit, receptacles located overhead in surface metal raceway mounted on cable tray.

5.15 Branch Circuits and Equipment Connections

- A. Branch circuits serving data center equipment cabinets and racks shall be from panelboards that are fed separately from any large electrical loads, such as HVAC equipment. Branch circuits shall be terminated in surface metal raceways mounted on cable trays above the racks as follows:
 - 1. Equipment Cabinet Outlets: dedicated 30 Amp, 120/208V 3-phase circuit (L18-30R) with ground installed in surface metal raceway above cabinets. Redundant outlets required.
 - 2. Equipment Rack Outlets: there shall be a minimum of two (2) 20 amp, 120 VAC circuits, with (2) duplex receptacles (5-20R) provided for each 19" equipment rack.
 - 3. MDF/IDF Rack Outlets: in addition to the rack outlets above, provide a 30 Amp, 120V dedicated circuit (L5-30R) with ground installed above each rack located in the MDF/IDF.
 - 4. Backboard outlets: 20 Amp, 120V dedicated circuit with two (2) 20 Amp duplex receptacles (5-20R) shall be installed at each backboard. Outlets shall be located where practicable at each end of the backboard; maintain separation of twelve inches (12") from telecommunications cables or terminations.

- B. The above circuits shall be served from the UPS backup source and labeled as such.
- C. Provide branch circuits from the UPS backup source for 1 receptacle per work station and 2 receptacles per office

5.16 Panelboards

- A. Panelboards shall comply with UL 67 and UL 50. Panelboards for use as service disconnecting means shall also conform to UL 869A.
- B. Panelboards shall be bolt-in circuit breaker type.
- C. Enclosure: door-in-door type with a combined catch and lock.
- D. Panelboard Buses: Main buses copper, isolated neutral bus, separate equipment grounding bus per UL 67; second "isolated" ground bus for data center panels.
- E. Panelboard for Non-Linear Loads: UL listed, UL heat rise tested for use on non-linear loads; neutral assembly rated at 200 percent of the phase bus current rating. Nameplates for panelboard rated for use on non-linear loads shall be marked "SUITABLE FOR NON-LINEAR LOADS."
- F. Circuit Breakers: UL 489, bolt-in, thermal magnetic-type having a minimum short-circuit current rating equal to the short-circuit current rating of the panelboard.
- G. Circuit breakers for HVAC equipment having motors shall be marked for use with HACR type and UL listed as HACR type.

5.17 Transformers

- A. NEMA ST 20, general purpose, dry-type, self-cooled, ventilated, 220 degrees C insulation system for transformers 15 kVA and greater, and shall have 180 degrees C insulation for transformers rated 10 kVA and less, with temperature rise not exceeding 80 degrees C under full-rated load in maximum ambient of 40 degrees C. Transformer of 80 degrees C temperature rise shall be capable of carrying continuously 130 percent of nameplate kVA without exceeding insulation rating.
- B. Transformers with Non-Linear Loads: Analysis of the connected loads shall be made to determine the harmonic contents and the appropriate K-Factor rating.
 - 1. Transformer insulation shall be a UL recognized 220 degrees C system. Neither the primary nor the secondary temperature shall exceed 220 degrees C at any point in the coils while carrying their full rating of non-sinusoidal load. Transformers are to be UL listed and labeled for its K-Factor rating in accordance with UL 1561.
 - 2. Transformers evaluated by the UL K-Factor evaluation shall be listed for 80 degrees C average temperature rise only. K-Factor rated transformers shall have an impedance range of 3 percent to 5 percent, and shall have a minimum reactance of 2 percent to prevent excessive neutral current when supplying loads with large amounts of third harmonic.

5.18 Underfloor Wiring

- A. The accessible underfloor areas will be used for routing feeders and backbone cabling. Conduit penetrations into the accessible underfloor area shall be sealed. Branch circuits and horizontal cabling shall be run overhead.

- B. Floor stanchion grounding and bonding requirements: See Telecommunications Grounding and Bonding herein.
- C. Water-leak Detection (By Mechanical): Leak detection sensors shall be installed along chilled water piping paths in the underfloor area.

6.0 ELECTRICAL CONNECTIONS FOR MECHANICAL EQUIPMENT

6.1 Extent of Electrical Connections

- A. This section includes final electrical connection of all equipment having electrical requirements.
- B. Make final connections for all owner furnished equipment including switches, receptacles, etc.
- C. See Mechanical Section for temperature control wiring requirements.
- D. Connection to equipment specified in the Mechanical Section shall be as follows:
 - 1. For motorized only equipment with built-in controllers (package equipment): connect power complete and provide an external disconnect at the unit.
 - 2. For motorized only equipment with external controller (non-packaged equipment): furnish the external controller and disconnect switch; install the controller, and make all power connections to the equipment.
 - 3. For electric duct heaters with built in controllers (package type equipment): connect power complete and provide an external disconnect switch at the unit.
 - 4. For electric duct heaters with remote controllers (non-package type equipment): connect power complete to the remote controller and provide an external disconnect switch at the remote controller. Provide all power wiring between the remote controller and the heaters.
 - 5. For combination motorized and electric heating packaged units specified with built in controllers and specified "single point connected": connect power complete and provide an external disconnect switch.

6.2 Tier 3 Circuiting Requirements

- A. Refer to the Mechanical Section for Data Center HVAC system design requirements.
- B. The HVAC systems include multiple air conditioning units with a combined cooling capacity to maintain critical space temperature and relative humidity at design conditions with sufficient redundant units to withstand failure of one electrical service switchboard.
- C. These air conditioning units are served by a chilled water system likewise sized to maintain design conditions with one electrical switchboard removed from service.
- D. This level of redundancy shall be obtained by furnishing two sources of power to each air conditioning unit.

6.3 Computer Room Air Conditioning (CRAC) Units

- A. Electrical supply to CRAC units shall be provided from separate panels to provide electrical redundancy. Power circuits shall be distributed among a number of power panelboards to minimize the effects of electrical system failures on the air conditioning system.

- B. All Data Center/Server Room CRAC unit circuits shall be backed up by generator power.
- C. CRAC unit temperature control systems shall be powered through redundant dedicated circuits from the UPS system.

6.4 **Motor Starters and Motor Circuit Protective Devices**

- A. Furnish all motor controllers not furnished under the Mechanical Section. Install all motor controllers including all controllers not factory assembled into equipment furnished under the Mechanical Section.
 - 1. Magnetic motor Starters: full voltage non-reversing with three overloads sized to suit nameplate amperes of motor served, motor "On" and "Off" pilot lights, "Hand-Off-Auto" switch and auxiliary contacts for interlocking.
 - 2. Combination Motor Starter/Disconnect: fused switch type with all features of Paragraph 1 above. In addition, provide disconnect switch auxiliary contacts for disconnection of externally powered control circuits where applicable.
 - 3. Variable Frequency Drives: Multi-purpose, variable torque, with voltage and current ratings to match the 3-phase motor characteristics.
 - 4. Manual Starters: toggle switch type, lockable in the "Off" position, with overload relays, pilot light and enclosure as described below.
 - 5. Enclosures: all motor controllers shall be contained in an enclosure suitable for the environment in which the controller is mounted.
 - 6. Overload Devices: melting alloy or bimetallic type. One overload shall be provided for each phase. Provisions shall be made for resetting the overload devices from outside the starter enclosure. Provide ambient compensated overload devices only when the motor is at a constant temperature and the controller is subject to a separate, varying temperature.

7.0 **TELECOMMUNICATIONS GROUNDING AND BONDING**

7.1 **General Requirements**

- A. Grounding systems shall comply with ANSI/TIA/EIA-J-STD-607-A Commercial Building Grounding and Bonding Requirements for Telecommunications.
- B. Establish a common bonding network (CBN) and signal reference grid within the data center by bonding the electrically continuous access-floor system to the building grounding system as described in IEEE Standard 1100 for the bonding of telecommunications and computer equipment.
- C. Coordinate with Access flooring specifications to ensure that the floor system has been designed to function as a data center grounding infrastructure.
- D. Bonding Conductors
 - 1. ASTM B 1, solid copper wire for sizes No. 8 AWG and smaller diameter; ASTM B 8, Class B, stranded copper wire for sizes No. 6 AWG and larger diameter.
 - 2. Bonding conductors shall be installed for each PDU and panelboard, sized per NEC 250.122

3. Equipment Bonding Conductors:
 - a. 6 AWG or larger bonding conductor to HVAC equipment
 - b. 4 AWG or larger bonding conductor to each column in the Data Center/Server Room
 - c. 6 AWG or larger bonding conductor to each cable ladder, cable tray, and cable wireway entering room
 - d. 6 AWG or larger bonding conductor to each conduit, water pipe, and duct entering room
 - e. 6 AWG or larger bonding conductor to every 6th access floor pedestal in each direction
 - f. 6 AWG or larger bonding conductor to each computer or telecommunications cabinet, rack, or frame. Do not bond racks, cabinets, and frames serially.
- E. Telecommunications Grounding and Bonding (TIA J-STD-607-A)
 1. A Telecommunication Bonding Backbone (TBB) is required between the telecommunications main grounding busbar (TMGB) and all telecommunications grounding busbars (TGBs). Size in accordance with the following:

TBB length linear feet	TBB Size (AWG)
Less than 13	6
14 - 20	4
21 - 26	3
27 - 33	2
34 - 41	1
42 - 52	1/0
53 - 66	2/0
Greater than 66	3/0

2. TBB conductor type: insulated copper
3. A Bonding Conductor for Telecommunications is required between the telecommunications main grounding busbar (TMGB) and the electrical service ground in accordance with TIA J-STD-607-A. The bonding conductor for telecommunications shall be sized the same as the TBB.
4. Telecommunications Grounding Busbars: corrosion-resistant copper grounding busbar electroplated for reduced contact resistance.
 - a. Provide a telecommunications main grounding busbar (TMGB) in the telecommunications entrance room(s) and a (TGB) in all other telecommunications equipment areas and enclosures. Refer to Telecommunications section, 4.2 Data Center Structure, for area descriptions
 - b. Size the TMGB and the TGBs in accordance with the immediate application requirements and with consideration of future growth.
 - c. Minimum dimensions: 0.25 in thick x 4 in wide for the TMGB and 2 in wide for TGBs with lengths as required; Listed by a nationally recognized testing laboratory.

8.0 STANDBY POWER FOR EMERGENCY POWER AND LIGHTING

8.1 Engine-Generator

- A. Diesel engine driven generator set(s) with synchronization and automatic transfer switches to activate generator upon loss of primary electrical service.
- B. Standby generator system shall provide power to the uninterruptible power supply system and mechanical equipment required to maintain data center mission critical operations.
- C. On-site fuel storage tanks should be sized to provide a minimum of 24 hours of generator operation at the design loading condition.

8.2 Uninterruptible Power Supply (UPS)

- A. Provide static UPS systems for ride-through capability during a power outage until the generators start and come on-line.
- B. The system shall be capable of automatic and manual internal bypass and be equipped with external means to bypass the system and avoid interruption of power in the event of system failure or maintenance.
- C. Provide individual battery systems for a minimum of 5 minute capacity at full-rated UPS load.
- D. Pushbutton Stations (EPO): UPS systems shall be tied to the EPO (Emergency Power Off) system so that the UPS systems do not continue to provide power if the EPO is activated.
- E. Refer to IEEE Standard 1100 for additional information on UPS system design.

8.3 Battery for Standby Power

- A. A combination of generator and battery standby systems may be used to address project requirements.
- B. Provide battery systems in compliance with governing regulations.

8.4 Emergency Power

- A. Provide standby power to the following systems required for code compliance, security, life safety, loss prevention, and data center operations:
 - 1. Emergency lighting
 - 2. Fire Alarm System
 - 3. Communications System
 - 4. Security System
 - 5. UPS systems

8.5 Emergency Lighting

- A. Provide emergency lighting for illumination of egress paths and exit markings in accordance with NFPA 101, Life Safety Code (LSC), and at data center operations and security as follows:
 - 1. Exit signs
 - 2. Egress paths
 - 3. Exterior exit doors

4. Mechanical, electrical, and communications equipment rooms
5. Administrative Offices
6. Data Center/Server Room
7. Security Office

9.0 FIRE PROTECTIVE SYSTEMS

9.1 General

- A. Fire detection systems shall be designed in accordance with the IBC, NFPA 75, and NFPA 72. Provide all required electrical connections between the data center fire protective systems describe hereafter and existing facility fire alarm system.
- B. Provide electrical connections for mechanical smoke control methods requiring an electrical source.
- C. Provide a Very Early Smoke Detection (VESDA) pre-action cross-zoned control system in the Data Center/Server Room. Provide required connections between the system control panel and automatic extinguishing systems provided under the mechanical section. See Mechanical Section, 22.0 Fire Protection.
- D. All wall and floor penetrations shall be sealed with firestop materials that match the fire rating of the system penetrated.
- E. Coordinate specific fire alarm type(s), fire protection, and central reporting requirements of the installations with the Fire Marshal/Chief.

9.2 System Devices for Fire Alarm

- A. Area Smoke Detectors (Photo-Electric): Locate area smoke detectors in the following spaces:
 1. In Corridors spaced at no more than 42 ft apart, and elsewhere at a maximum area of 900 sq. ft. per detector
 2. In Mechanical, electrical, and communications equipment rooms
 3. At duct penetrations into Data Center/Server Room to operate fire/smoke dampers
 4. In the underfloor space of the Data Center/Server Room to interrupt air circulation
- B. Duct Smoke Detectors (Photo-Electric):
 1. Provide in return ductwork of HVAC units and connect to fire alarm system
 2. Supply Ducts: Provide downstream of HVAC units over 2000cfm to shut-down unit upon sensing smoke. Detector annunciates at fire alarm panel but will not activate smoke control system

9.3 Automatic Detection Systems

- A. An automatic detection system shall be installed in the following locations:
 1. At the ceiling level throughout the computer area.
 2. Below the raised floor of the computer area containing cables.

3. Above the suspended ceiling and below the raised floor in the computer room where these spaces are used to recirculate air to other parts of the building
 - B. Where interlock and shutdown devices are provided, the electrical power to the interlocks and shutdown devices shall be supervised by the fire alarm control panel.
 - C. The alarms and trouble signals of automatic detection or extinguishing systems shall be arranged to annunciate at a constantly attended locations.
- 9.4 **Annunciator Panels**
- A. Either digital or matrix type indicating floor or zone of floor and type of device initiating alarm or trouble
 - B. Locate annunciator panels in Fire Command Center and Data Center/Server Room
 - C. Devices that Require Alarm Annunciation
 1. Pull stations
 2. Area smoke detectors
 3. Water flow switches
 4. Heat detectors
 5. Sprinkler valve tamper switches (trouble)

10.0 **SECURITY SYSTEMS**

10.1 **Video Surveillance System**

- A. Video Surveillance System: Video surveillance for data center, corridors, public entry, and other areas as directed by the Owner.

10.2 **Access Control**

- A. Provide dual-technology Proximity/Biometric type card readers in selected locations to secure sensitive areas of the data center from public areas.

10.3 **Physical Security**

- A. Telecommunications cabling associated with the data center shall not be routed through spaces accessible by the public or by other tenants of the building. Route cables enclosed in conduit or other secure pathways. Any maintenance access doors, pull boxes, or splice boxes shall be equipped with a lock.
- B. Any maintenance holes on building property or under control of the data center owner shall be locked and monitored by the data center security system using a camera and remote alarm.
- C. Entrance to utility tunnels used for telecommunications entrance rooms and other data center cabling shall be locked. If the tunnels are used by multiple tenants or cannot be locked, telecommunications cabling for data centers shall be in rigid conduit or other secure pathway.

END OF ELECTRICAL

Telecommunications - General	2
1.0 Scope.....	2
2.0 Standards And Codes	2
3.0 Data Center Design Overview.....	2
3.1 General	2
3.2 Tiering	2
3.3 Data Center Communications Systems	3
4.0 Data Center Spaces.....	3
4.1 General	3
4.2 Data Center Structure.....	3
5.0 Data Center Cabling Systems	4
5.1 General	4
5.2 Horizontal Cabling	4
5.3 Backbone Cabling.....	5
6.0 Cabling Pathways.....	5
6.1 General	5
6.2 Security for Data Center Cabling.....	5
6.3 Separation of Power and Telecommunications Cables	6
6.4 Telecommunications Entrance Pathways.....	6
6.5 Access Floor Systems.....	6
6.6 Overhead Cable Trays.....	6
7.0 Data Center Cabling System Infrastructure.....	6
7.1 General	6
7.2 Telecommunications Cabling	7
7.3 Cable And Equipment Color Codes	8
7.4 Equipment Racks.....	9
7.5 Equipment Cabinets.....	11
7.6 Backboards.....	12
7.7 Connector Blocks (Systimax VisiPatch 360 System)	13
7.8 Patch Panels (Category 6).....	13
7.9 Fiber Optic Patch Panels	13
7.10 Optical Fiber and Copper Patch Cords for Patch Panels	14
7.11 Telecommunications Outlet/Connector Assemblies	14
7.12 Grounding and Bonding Products.....	15
7.13 Firestopping Material	15
7.14 Tests, Inspections, And Verifications	15

TELECOMMUNICATIONS - GENERAL

1.0 SCOPE

- A. The purpose of this document is to provide requirements and guidelines for the design and installation of a consolidated Data Center for King County.
- B. This section is intended for use by designers who need a comprehensive understanding of the data center cabling system and network design.

2.0 STANDARDS AND CODES

- A. Applicable industry codes, standards, or publications referenced hereinafter apply to equipment, materials, and construction covered herein. See General Provisions Section for list of references.
- B. The minimum requirements of the latest edition of International Building Code (IBC), NFPA 70, National Electrical Code (NEC), and ANSI/TIA/EIA Communications Standards shall apply unless more stringent requirements are specified and/or dictated.

3.0 DATA CENTER DESIGN OVERVIEW

3.1 General

- A. The data center telecommunications cabling and pathway system shall include permanently installed backbone and horizontal cabling, horizontal and backbone pathways, service entrance facilities, work area pathways, telecommunications outlet assemblies, conduit, raceway, and hardware for terminating and interconnecting cabling.
- B. The horizontal system shall be wired in a star topology from the workstation outlets to the horizontal cross-connect or main cross-connect at the center of hub of the star.
- C. The backbone cabling and pathway system includes intrabuilding interconnecting cabling, pathway, and terminal hardware. The intrabuilding backbone provides connectivity from the horizontal cross-connects to the main cross-connect. The backbone system shall be wired in a star topology with the MC at the center or hub of the star.

3.2 Tiering

- A. The data center design shall meet the requirements for a Tier III classification as defined by The Uptime Institute, Inc. for a concurrently maintainable site infrastructure.
- B. Tier III level capability allows for any planned site infrastructure activity without disrupting the computer hardware operation in any way. Planned activities include preventive and programmable maintenance, repair and replacement of components, addition or removal of capacity components, testing of components and systems, and more. Sufficient capacity and distribution must be available to simultaneously carry the load on one path while performing maintenance or testing on the other path.

3.3 Data Center Communications Systems

- A. Required systems include but are not limited to:
 - 1. Data Communications
 - 2. Voice Communications
 - 3. Dual-band transceiver with distributed antennas to facilitate cell phone/PCS communications indoors
 - 4. Optical fiber interconnects
 - 5. Wireless connectivity to KCPAN
 - 6. Wireless connectivity to KCWAN

4.0 DATA CENTER SPACES

4.1 General

- A. Data center spaces dedicated to the support of the telecommunications infrastructure includes:
 - 1. The entrance room
 - 2. Main distribution area (MDF)
 - 3. Horizontal distribution area (IDF)
 - 4. and equipment distribution area (EDA).

4.2 Data Center Structure

- A. Entrance Room
 - 1. The entrance room is the interface between the data center structured cabling system and inter-building cabling, both access provider and King County owned. This room includes the access provider demarcation hardware and access provider equipment. Multiple entrance rooms are desired to provide additional redundancy for access provider-provisioned circuits.
 - 2. The entrance room locations are outside the data center area. The designer shall confirm exact location(s) of the entrance room(s) and include pathways between the entrance rooms and the data center.
 - 3. The entrance room(s) interfaces with the computer room through the main distribution area.

B. Main Distribution Area (MDF)

1. This space is a room labeled "MDF." and is located inside the Data Center/Server Room. The main distribution area includes the main cross-connect (MDF), which is the central point of distribution for the data center structured cabling system.
2. The main distribution area serves horizontal distribution areas or equipment distribution areas within the data center and telecommunications rooms located outside the computer room space to support office spaces, Command Center/NOC, and other external support rooms.

C. Horizontal Distribution Area (IDF)

1. The horizontal distribution area is used to serve equipment areas when the HC is not located in the main distribution area. The horizontal distribution area includes the IDF, which is the distribution point for cabling to the equipment distribution areas.
2. The horizontal distribution areas are located inside the Data Center/Server Room. The horizontal distribution area includes LAN switches, SAN switches, and Keyboard/Video/Mouse (KVM) switches, etc. for the end equipment located in the equipment distribution areas.
3. Several horizontal distribution areas are required.

D. Equipment Distribution Area (EDA)

1. The equipment distribution area is the space allocated for equipment cabinets housing the computer systems and equipment. These areas shall not serve the purposes of an entrance room, main distribution area or horizontal distribution area.
2. There may be an optional interconnection point within the horizontal cabling, called a zone distribution area. This area is located between the horizontal distribution area and the equipment distribution area to allow frequent reconfiguration and flexibility.

5.0 DATA CENTER CABLING SYSTEMS

5.1 General

5.2 Horizontal Cabling

A. Topology:

1. The horizontal cabling shall be installed in a star topology. Each mechanical termination in the equipment distribution area shall be connected to a horizontal cross-connect in the horizontal distribution area or main cross-connect in the main distribution area via a horizontal cable.
2. Horizontal cabling shall contain no more than one consolidation point in the zone distribution area between the horizontal cross-connect in the horizontal distribution area and the mechanical termination in the equipment distribution area.

B. Horizontal Cabling Distances:

1. The horizontal cabling distance is the cable length from the mechanical termination of the media at the horizontal cross-connect in the horizontal distribution area or the main distribution area to the mechanical termination of the media in the equipment distribution area. The maximum horizontal distance shall be 90 m (295 ft), independent of media type.
2. The maximum channel distance including equipment cords shall be 100 m (328 ft).
3. Horizontal cable distances in the Data Center/Server Room shall be reduced to compensate for longer equipment cords in the data center distribution areas.

5.3 **Backbone Cabling**

- A. The backbone cabling shall allow network reconfiguration and future growth without disturbance of the backbone cabling.
- B. The backbone cabling shall support different connectivity requirements, including both the network and physical console connectivity such as local area networks, wide area networks, storage area networks, computer channels, and equipment console connections.
- C. Topology:
 1. The backbone cabling shall use the hierarchical star topology wherein each horizontal cross-connect in the horizontal distribution area is cabled directly to a main crossconnect in the main distribution area.
 2. There shall be no more than one hierarchical level of crossconnect in the backbone cabling. From the horizontal cross-connect, no more than one crossconnect shall be passed through to reach another horizontal cross-connect.

6.0 **CABLING PATHWAYS**

6.1 **General**

- A. Telecommunications pathways shall be designed in accordance with TIA/EIA-569-A, TIA-942, and as specified hereinafter.
- B. Except where otherwise specified, data center cabling pathways shall adhere to the specifications of ANSI/TIA-569-B.
- C. System furniture pathways shall be in accordance with UL 1286.
- D. See electrical section paragraph "Telecommunications Pathway Design," for additional information.

6.2 **Security for Data Center Cabling**

See Electrical Section, 10.0 Security Systems.

6.3 Separation of Power and Telecommunications Cables

- A. A separation of 12" between power and telecommunications cables shall be maintained to minimize longitudinal coupling between power cables and twisted-pair copper cables.
- B. Refer to NFPA 70, article 800 or applicable WAC code for additional installation requirements.

6.4 Telecommunications Entrance Pathways

- A. Entrance pathway types and materials are described in the electrical section.
- B. The designer shall confirm exact location(s) of the entrance room(s) and include pathways between the entrance rooms and the data center

6.5 Access Floor Systems

- A. See architectural section for access floor specifications, installation, and performance requirements.
- B. See electrical section paragraph "Telecommunications Grounding and Bonding," for access floor grounding and bonding requirements.

6.6 Overhead Cable Trays

- A. Overhead cable trays shall be used to distribute network cabling as well as a support for power distribution to equipment cabinets within the Data Center/Server Room.
- B. Coordinate cable tray routes with equipment cabinet layouts to facilitate power and communication cable distribution.
- C. See electrical section paragraph "Cable Trays," for additional information.

7.0 DATA CENTER CABLING SYSTEM INFRASTRUCTURE

7.1 General

- A. Cabling and interconnecting hardware and components for telecommunications systems shall be UL listed or third party independent testing laboratory certified, and shall comply with NFPA 70 and conform to the requirements specified herein.
- B. UL or third party certified. Where equipment or materials are specified to conform to industry and technical society reference standards of the organizations, submit proof of such compliance.
- C. The label or listing by the specified organization will be acceptable evidence of compliance. In lieu of the label or listing, a certificate from an independent testing organization, competent to perform testing, and approved by the Owner. The certificate shall state that the item has been tested in accordance with the specified organization's test methods and that the item complies with the specified organization's reference standard.
- D. A system of telecommunications cabling and pathway components complete with outlets, cables, connecting hardware and telecommunications cabinets/racks arranged in star topology.

7.2 Telecommunications Cabling

- A. Cabling shall be UL listed for the application and shall comply with TIA/EIA-568-B.1, TIA/EIA-568-B.2, TIA/EIA-568-B.3, and NFPA 70. Labeling system for cabling shall be in accordance with TIA/EIA-606-A and UL 969.
- B. Backbone Cabling
 - 1. Backbone Copper:
 - a. Comply with ICEA S-90-661, TIA/EIA-568-B.1, TIA/EIA-568-B.2, NEMA WC 66 and UL 444
 - b. Copper backbone cable shall be solid conductor, 24 AWG, 100 ohm, 150-pair UTP (Unshielded twisted pair), formed into 25 pair binder groups covered with a white thermoplastic jacket. Confirm exact pair densities required during design phase.
 - c. Cable shall be imprinted with manufacturers name or identifier, flammability rating, gauge of conductor, transmission performance rating (category designation) at regular intervals not to exceed 2 feet.
 - d. Cable shall be communications general purpose (CM or CMG), communications plenum (CMP) or communications riser (CMR) rated cabling in accordance with NFPA 70. Type CMP and CMR may be substituted for type CM or CMG and type CMP may be substituted for type CMR in accordance with NFPA 70.
 - e. Color coding shall comply with industry standards for 25 pair cables.
 - 2. Backbone Optical Fiber:
 - a. Comply with ICEA S-83-596, TIA/EIA-568-B.3, UL 1666 and NFPA 70. Cable outer jacket shall be imprinted at regular intervals not to exceed 40 inches with fiber count, fiber type and aggregate length.
 - b. Optical fiber cables shall be tight buffered and comply with the following:
 - 1. TIA/EIA-492AAAA-A, multimode, 62.5/125-um diameter, 0.275 numerical aperture
 - 2. TIA/EIA-492CAAA, single-mode, 8/125-um diameter, numerical aperture
 - c. Backbone cables shall be 24-strand unless other strand densities are indicated.
 - d. Cable shall be nonconductive optical fiber general purpose (OFN or OFNG), nonconductive optical fiber plenum cable (OFNP), and nonconductive optical fiber riser cable (OFNR) rated cable in accordance with NFPA 70 and UL 910.
 - e. Type OFNP or OFNR may be substituted for type OFN or OFNG and type OFNP may be substituted for type OFNR in accordance with NFPA 70.

C. Horizontal Cabling:

1. Horizontal Copper

- a. Horizontal copper cable shall comply with TIA/EIA-568-B.2, UL 444, NEMA WC 66, ICEA S-90-661 UTP (unshielded twisted pair), 100 ohm.
- b. Construct cables using four each individually twisted pair, 24 AWG conductors, Category 6, with a blue thermoplastic jacket.
- c. Cable shall be imprinted with manufacturers name or identifier, flammability rating, gauge of conductor, transmission performance rating (category designation) at regular intervals not to exceed 2 feet.
- d. Cables shall be communications general purpose (CM or CMG), communications plenum (CMP) or communications riser (CMR) rated in accordance with NFPA 70. Type CMP and CMR may be substituted for type CM or CMG and type CMP may be substituted for type CMR in accordance with NFPA 70.
- e. Cable shall be nonconductive optical fiber general purpose (OFN or OFNG), nonconductive optical fiber plenum cable (OFNP), and nonconductive optical fiber riser cable (OFNR) rated cable in accordance with NFPA 70 and UL 910.
- f. Type OFNP or OFNR may be substituted for type OFN or OFNG and type OFNP may be substituted for type OFNR in accordance with NFPA 70.

7.3 **Cable And Equipment Color Codes**

- A. Cross-Connect Field Color Codes shall adhere to TIA/EIA-606-A color coding standards in accordance with the following:

Orange	Demarcation point
Green	Network connections
Purple	Common equipment, private branch exchange (PBX)
White	First-level backbone (e.g., MDF to an IDF)
Gray	Second-level backbone (e.g., EDA to an IDF)
Blue	Horizontal cable
Yellow	Miscellaneous (auxiliary, alarms, security)
Red	Reserved for future use (also, key telephone systems).

B. Cable Terminations

1. Include termination materials, hardware and equipment to terminate horizontal and backbone cabling in the telecommunications entrance facility and telecommunication equipment rooms.
2. Color coding of telecommunications interconnecting hardware shall be in accordance with TIA/EIA-606-A.

7.4 **Equipment Racks**

- A. Equipment Racks: 19 inch floor mounted universal type. Equip rack with vertical and horizontal cable management channels, top and bottom cable troughs, grounding lug and a surge protected power strip with 6 duplex 20 amp receptacles.
- B. Vertical cabling Section, 6" wide: Racks shall have a Combination Cabling Section (CCS) (Chatsworth 30165) installed on the outside ends of two or more racks, or on each side of a single rack.
- C. Vertical cabling Section, 12" wide: Master Cabling Sections (MCS) (Chatsworth 40097-X03) installed between each rack of a multi-rack installation.
- D. Racks shall have a vertical Combination Cabling Section (CCS) (Chatsworth 30165) installed on the outside ends of two or more racks, or on each side of a single rack.
- E. Racks shall be laid out in a way that allows future expansion and access to all sides with a minimum of forty-eight inches (48") of clear space in front and thirty-six inches (36") in the back.
- F. There shall be a twelve inch (12") cable runway above the rack and extending to the backboard. This rack and cable runway shall be used for data networking equipment and patch cables.
- G. Rack and associated equipment shall be equipped with seismic bracing. This bracing shall be installed in a way that does not interfere with accessibility or installation of equipment in the open frame rack.
- H. All rack(s) and associated equipment shall be grounded and bonded to the TMGB or TGB.
- I. Rack Equipment and Accessory List:
 - 1. CHATSWORTH Universal Rack
 - a. Size: 19"W x 7' H x 3" D
 - b. Color: Clear
 - c. RMU: 45
 - d. Posts: 2 with two top angles
 - e. UL Listed
 - f. Part No: 48353-503
 - 2. Mounting Screws
 - a. Size: 12-24
 - b. Zinc Plated
 - c. Quantity: 50
 - d. Combination Pan Head
 - e. Pilot Point
 - f. Part No: 40606-001
 - 3. Rack base dust cover
 - a. Size: 19" W
 - b. Color: Clear
 - c. Channel size: 3"
 - d. Part No. 41050-519

4. Cable Management:
 - a. Rack Top Mount Cable Trough
 - b. Size: 6" W x 2.25" L
 - c. Color: Clear
 - d. Part No: 12382-519
5. MCS-EFX Master Cabling Section
 - a. Size: 12" W x 7' H x 21.23" D
 - b. Color: Black
 - c. Extended Fingers
 - d. Part No: 40097-703
6. CCS-EFX Combination Cabling Section
 - a. Size: 12" W x 7' H x 14.94" D
 - b. Color: Black
 - c. Extended Fingers
 - d. Part No: 40100-703
7. Large Horizontal Ring Panel
 - a. Size: 19" W x 3.47" H x 6" D
 - b. Color: Clear
 - c. Part No: 11564-719
8. Accessories:
 - a. Small Peripheral Shelf
 - b. Size: 19"W x 3.44" H x 10" D
 - c. Color: Clear
 - d. Non-vented
 - e. Single sided
 - f. Part No: 10758-501
9. Heavy Duty Equipment Shelf
 - a. Size: 19" W x 7.16" H x 20" D
 - b. Color: Clear
 - c. Non-vented
 - d. Double-Sided
 - e. Part No: 11164-519
10. Double-Sided Shelf
 - a. Size: 19" W x 6.13" H x 21.75" D
 - b. Color: Clear
 - c. Non-vented
 - d. Double-sided
 - e. Part No: 40108-519

11. Concrete Floor Installation Kit
 - a. Part No. 40604-003
12. Rack Seismic Gusset Kit
 - a. Color: Black
 - b. Part No. 11592-701

7.5 Equipment Cabinets

- A. Cabinets (CPI TeraFrame Series): 24" wide freestanding modular type, equipped with Air dam, blanking panels and 208V 3-phase, 30A cabinet distribution unit (Server Technology C-48VDY-L2130).
 1. Cabinet Enclosure:
 - a. Size: 23.6" W x 83.5" H x 40.40" D
 - b. Color: Black
 - c. RMU: 45
 - d. Square Punched Rails
 - e. Perforated Metal Front Door
 - f. Perforated Metal Rear Door
 - g. Two Point Swing Handle Latch
 - h. Server Top Panel
 - i. 2 Solid Sides
 - j. Part No: FF1K-112C-C12
 2. Multi-Mount Hardware Kit:
 - a. Size: 12-24
 - b. Color: Black
 - c. Quantity: 25
 - d. Part No: 12639-001
 - e. Air Dam Kit
 - f. Size: 23.6" W x 45U H
 - g. Color: Black
 - h. Part No: 34521-C05
 3. Cable Management:
 - a. Large Horizontal Ring Panel
 - b. Size: 19" W x 3.47" H x 6" D
 - c. Color: Black
 - d. Part No: 11564-719
 4. Accessories:
 - a. MegaFrame Fixed Shelf
 - b. Size: 19" W x 3.5" H x 29" D
 - c. Color: Black
 - d. Single Sided

- e. Non-Vented
- f. Part No: 14070-719
- 5. Filler Panel (4U):
 - a. Size: 19" W x 6.97" H
 - b. Color: Black
 - c. Metal
 - d. Part No: 30026-704
- 6. Filler Panel (6U):
 - a. Size: 19" W x 10.47" H
 - b. Color: Black
 - c. Metal
 - d. Part No: 30026-006
- 7. Filler Panel (10U):
 - a. Size: 19" W x 17.47" H
 - b. Color: Black
 - c. Metal
 - d. Part No: 30026-010
- 8. Snap-in Filler Panel (1U):
 - a. Size: 19" W x 1.75" H
 - b. Color: Black
 - c. Plastic
 - d. Part No: 34537-000 (1 each)
 - e. Part No: 34537-001 (6 each)
- 9. Snap-in Filler Panel (2U):
 - a. Size: 19" W x 3.5" H
 - b. Color: Black
 - c. Plastic
 - d. Part No: 34538-000 (1 each)
 - e. Part No: 34538-001 (6 each)
- 10. Concrete Floor Installation Kit: Part No. 40604-003

7.6 Backboards

- A. Backboards shall be fire rated, interior grade plywood 3/4 inch thick 4 by 8 feet. Backboards shall be installed on a minimum of two walls in the telecommunication spaces.
- B. Cable guides of ring or bracket type shall be mounted on backboards for cable management.

7.7 Connector Blocks (Systemax VisiPatch 360 System)

- A. Specify a complete system of connector blocks for copper twisted-pair backbone, voice, and auxiliary circuit terminations including but not limited to:
 - 1. Wall or rack mounted VisiPatch units
 - 2. Vertical and horizontal wire management throughout; wire management for the VisiPatch wall field shall be required and specified with backboard elevations.
 - 3. VisiPatch units for horizontal cable terminations
 - 4. VisiPatch units for copper backbone and PBX extension terminations
 - 5. VisiPatch units for network interface cable terminations
 - 6. and space for future VisiPatch units.
- B. The VisiPatch units for the workstation terminations and the copper PBX extensions shall occupy the bottom two thirds (2/3) of the VisiPatch field, with the space left for future VisiPatch units at the top one third (1/3).
- C. The top one third (1/3) of the VisiPatch field is to be used to terminate backbone and network interface Cables from the rack mounted network equipment.
- D. Patch cables shall be VisiPatch type, and used to cross-connect the upper one third (1/3) to the lower two thirds (2/3).
- E. Allow for the number of horizontal and backbone cables terminated on the block plus 25 percent spare.

7.8 Patch Panels (Category 6)

- A. Comply with TIA/EIA-568-B.1 and TIA/EIA-568-B.2. Panels shall be third party verified and shall comply with EIA/TIA Category 6 requirements. Panel shall be constructed of aluminum and shall be cabinet, rack, and wall mountable and compatible with EIA-310-D 19 inch mounting. Panels shall accommodate 48 non-keyed, 8-pin modular ports, wired to T-568B wiring designation.
- B. Patch panels shall terminate the data center cabling on Type 110 IDCs and shall utilize a printed circuit board interface. The rear of each panel shall have incoming cable strain-relief and routing guides. Panels shall have each port factory numbered and be equipped with laminated plastic nameplates above each port.

7.9 Fiber Optic Patch Panels

- A. Compatible with EIA-310-D 19 inch equipment racks; constructed of steel or aluminum, and suitable for cabinet or rack mounting; equip with low-density TIA/EIA-604-10A type LC adapters with thermoplastic alignment sleeves for use with multimode or single-mode optical fibers.
- B. The front of the panel shall have a key-lockable hinged door. The rear of each panel shall have a cable management tray a minimum of 8 inches deep with removable cover, incoming cable strain-relief and routing guides. Panels shall have each adapter factory numbered and be equipped with laminated plastic nameplates above each adapter.

- C. Fiber optic panels shall be labeled in a consistent manner with descriptive and unique labels indicating "to" and "from" on each end. Individual fiber connectors shall be labeled with the same label on each end. Labeling scheme shall be approved by King County prior to use.

7.10 Optical Fiber and Copper Patch Cords for Patch Panels

- A. Patch cords shall meet minimum performance requirements specified in TIA/EIA-568-B.1, TIA/EIA-568-B.2 and TIA/EIA-568-B.3.
- B. Verify quantities, lengths, and jacket colors with the owner during the design phase.

7.11 Telecommunications Outlet/Connector Assemblies

A. Copper Cable Outlet/Connectors

1. Outlet/connectors shall comply with FCC Part 68, TIA/EIA-568-B.1, and TIA/EIA-568-B.2.
2. UTP outlet/connectors shall be UL 1863 listed, non-keyed, 8-pin modular jacks, constructed of high impact rated thermoplastic housing and shall be third party verified and shall comply with TIA/EIA-568-B.2 Category 6 requirements.
3. Outlet/connectors provided for UTP cabling shall meet or exceed the requirements for the cable provided.
4. Outlet/connectors shall be terminated using a Type 110 IDC PC board connector, color-coded for both T-568A and T-568B wiring designations.
5. Each outlet/connector shall be wired T-568B.
6. UTP outlet/connectors shall comply with TIA/EIA-568-B.2 for 200 mating cycles.
7. Each workstation outlet shall have a minimum of three (3) RJ-45 jacks on a four (4) jack faceplate. Category 6 cables shall be run to each jack in the faceplate.
8. The jacks shall be labeled as "A", "B" & "C", prefaced by the communications faceplate numbering scheme proposed for the building, in accordance with the King County Labeling Standard.
9. All RJ-45 jacks shall be "universal", allowing voice or data to be used in any combination.
10. Cable length shall not exceed ninety (90) meters of installed cable from the workstation jack to the IDF patch panel.

B. Optical Fiber Adapters

1. Optical fiber adapters shall be type LC in accordance with TIA/EIA-604-10A.
2. Comply with EIA TIA-455-21-A for 500 mating cycles.

C. Optical Fiber Connectors:

1. Comply with EIA TIA-455-21-A. Optical fiber connectors shall be type LC in accordance with TIA/EIA-604-10A with thermoplastic ferrule, compatible with 62.5/125 multimode, and 8/125 single-mode fiber.
2. Optical fiber connectors shall provide a maximum attenuation of 0.3 dB with less than a 0.2 dB change after 500 mating cycles.

D. Faceplates:

1. Telecommunications cover plates shall comply with UL 514C, and TIA/EIA-568-B.1, TIA/EIA-568-B.2, TIA/EIA-568-B.3; constructed of high impact thermoplastic material to match color of receptacle/switch cover plates.
2. Labeling shall be in accordance with the King County Labeling Standard.

7.12 Grounding and Bonding Products

- A. Grounding shall be in accordance with UL 467, TIA J-STD-607-A, and NFPA 70. Components shall be identified as required by TIA/EIA-606-A.
- B. See electrical section paragraph "Telecommunications Grounding and Bonding," for additional information.

7.13 Firestopping Material

- A. Firestop all locations where cables penetrate fire rated surfaces. Materials and methods used shall be acceptable to the code authority having jurisdiction and shall maintain the fire integrity of the wall, floor, or ceiling surface penetrated.

7.14 Tests, Inspections, And Verifications

- A. Factory Reel Tests: Require documentation of the testing and verification actions taken by manufacturers to confirm compliance with TIA/EIA-568-B.1, TIA/EIA-568-B.3, and TIA/EIA-526-7 for single mode optical fiber, and TIA/EIA-526-14A for multimode optical fiber cables.

END OF SECTION